

BEF16-1114CP-W

Revisions

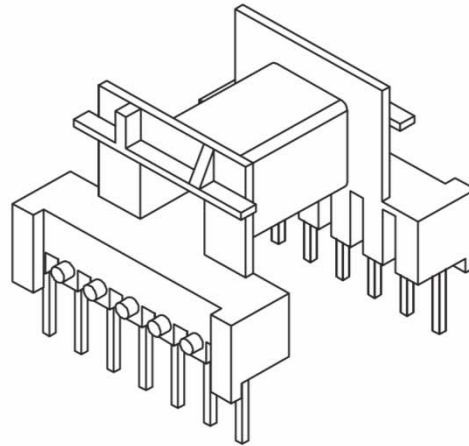
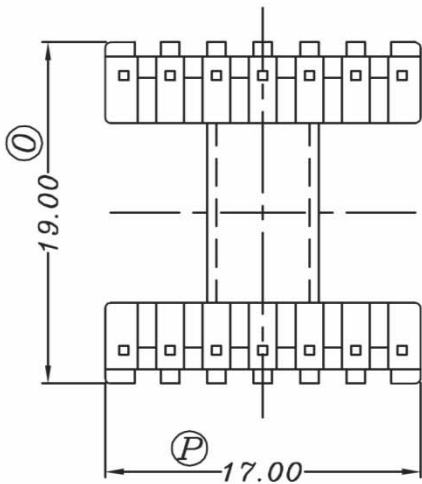
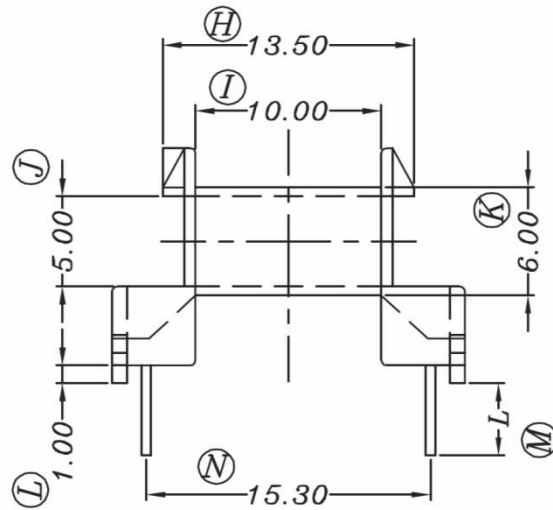
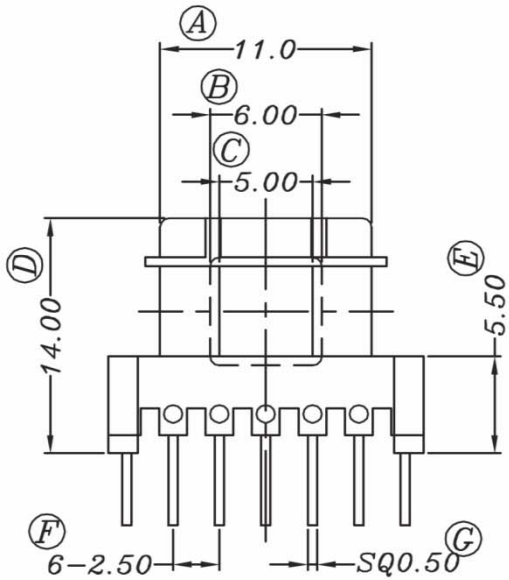

TDK Core: EF 16

Dimensions in mm

| | | |
|--|--------------------------------|----------------------------------|
| Country of Origin: China | RoHS Certified: YES | UL Molder Certification: E315110 |
| Bobbin Material: Sumitomo Phenolic PM9630 | Drawing Number: BEF16-1114CP-W | |
| UL File: E41429 | UL Rec: 94-V0 | WS-51623 |
| Pin Material: Steel Wire | | Pin Tension: 1.0Kgm min |
| Pin Plating: CuSn (~2%Cu) | | Part Number: BEF16-1114CP-W |
| MH&W International Corp Phone 201-891-8800 Email: sales@mhw-intl.com | | |