

BE 19/16-1112CP-P

Revisions			

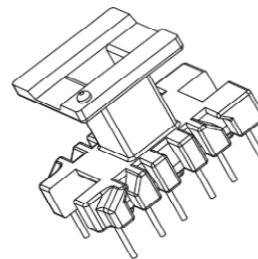
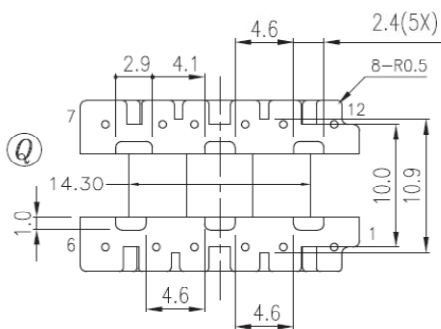
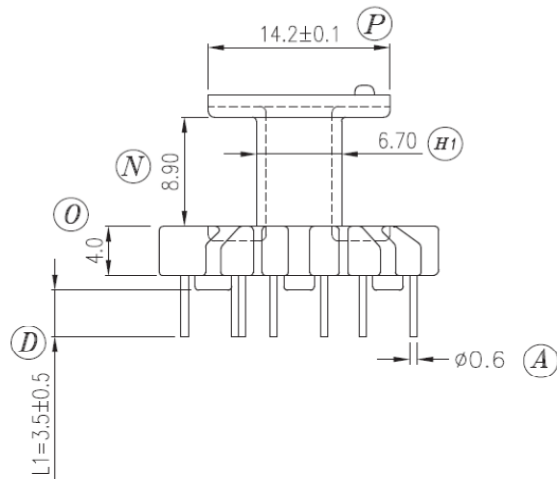
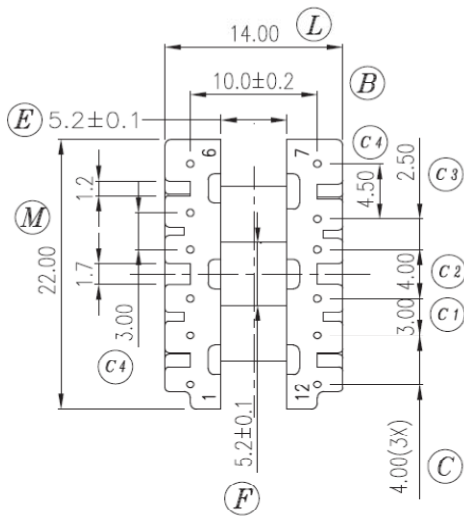
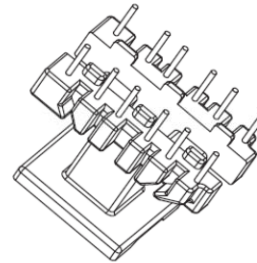
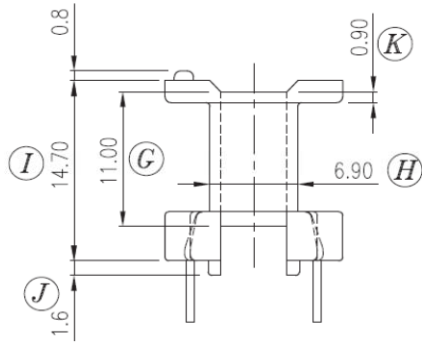

Dimensions in mm

Country of Origin: China	RoHS Certified: YES	Molder UL File Number: E163831
Bobbin Material: Sumitomo PM9630		Drawing Number: BE 19/16-1112CP-P
UL File: E41429	UL Rec: 94-V0	P-1946
Pin Material: Steel Wire (CP)		
Pin Tension: 1.5Kgm min		Finish: Tin
Part Number: BE 19/16-1112CP-P		
MH&W International Corp Phone 201-891-8800 Email: sales@mhw-intl.com		