

OD572

Core Dimensions

		OD(max)	ID(min)	HT(max)
Before coating	(mm)	57.15	35.56	13.97
	(inch)	2.250	1.400	0.550
After coating (Epoxy)	(mm)	58.00	34.70	14.86
	(inch)	2.285	1.368	0.585

Magnetic Dimensions

Cross Section (A)	Path Length (ℓ)	Window Area (Wa)	Volume (V)
1.444cm ²	14.30cm	9.48cm ²	20.65cm ³
0.244in ²	5.63in	1,871,000cmil	1.261in ³

OD 57.15mm / 2.250inch

ID 35.56mm
HT 13.97mm

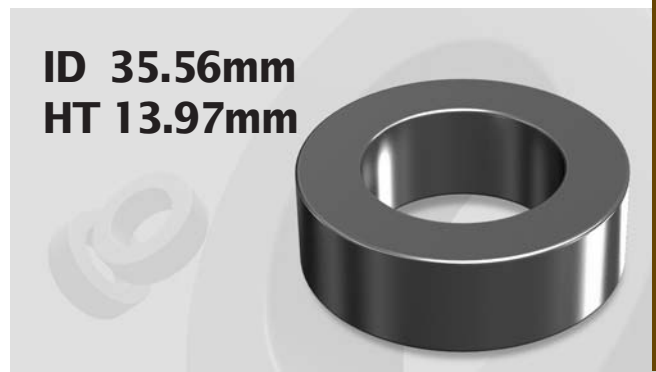

Winding Information

AWG Wire No.	Single Layer Dia(cm)	Turn	Rdc,Ω	AWG Wire No.	Single Layer Dia(cm)	Turn	Rdc,Ω
10	0.267	37	0.00644	19	0.0980	108	0.152
11	0.238	42	0.00920	20	0.0879	120	0.211
12	0.213	48	0.0133	21	0.0785	135	0.300
13	0.190	54	0.0188	22	0.0701	152	0.428
14	0.171	60	0.0263	23	0.0632	169	0.596
15	0.153	68	0.0376	24	0.0566	189	0.845
16	0.137	76	0.0531	25	0.0505	212	1.19
17	0.122	85	0.0746	26	0.0452	237	1.69
18	0.109	96	0.107	27	0.0409	263	2.35

Single layer winding with 1 inch leads

Available Cores

MPP	Part No.			AL (nH/N ²)	Perm. (μ)
	High Flux	Sendust	Mega Flux®		
CM572026	CH572026	CS572026	CK572026	33	26
CM572060	CH572060	CS572060	CK572060	75	60
-	-	CS572075	CK572075	94	75
-	-	CS572090	CK572090	112	90
CM572125	CH572125	CS572125	-	156	125
CM572147	-	-	-	185	147
CM572160	-	-	-	200	160
-	-	-	-	-	173
-	-	-	-	-	200

AL vs NI Curve (60μ, 125μ)

