

ER22/5.5/15 (pair of HER22/2.8/15) Core Series

STD AL VALUE

STD ITEM DESCRIPTION	AL-VALUE
PC95EL22/5.5/15 - Z	4550 ± 25%
PC95EL22/5.5/15 - A1120	1120 ± 15%
PC33EL22/5.5/15 - Z	2600 ± 25%
PC33EL22/5.5/15 - A80	80 ± 3%
PC33EL22/5.5/15 - A125	125 ± 5%
PC33EL22/5.5/15 - A200	200 ± 7%

Note) ER/ER combination

ER22/5.5/15 core

Sym.	DIMENSIONS (mm)		
	SPEC.	Min.	Max.
A1	22.10 ± 0.35	21.75	22.45
B	2.75 ± 0.1	2.65	2.85
C1	15.25 ± 0.25	15.00	15.50
φ D	6.8 ± 0.1	6.7	6.9
E	19.7 ± 0.3	19.4	20.0
F	1.0 ± 0.1	0.9	1.1
H	1.20 typ.		

Core parameters

C_1 (mm ⁻¹)	0.505
l_e (mm)	23.2
A_e (mm ²)	46.0
V_e (mm ³)	1067
A_{min} (mm ²)	36.3
A_{cw} (mm ²)	12.9

Core Shape & Nomenclature

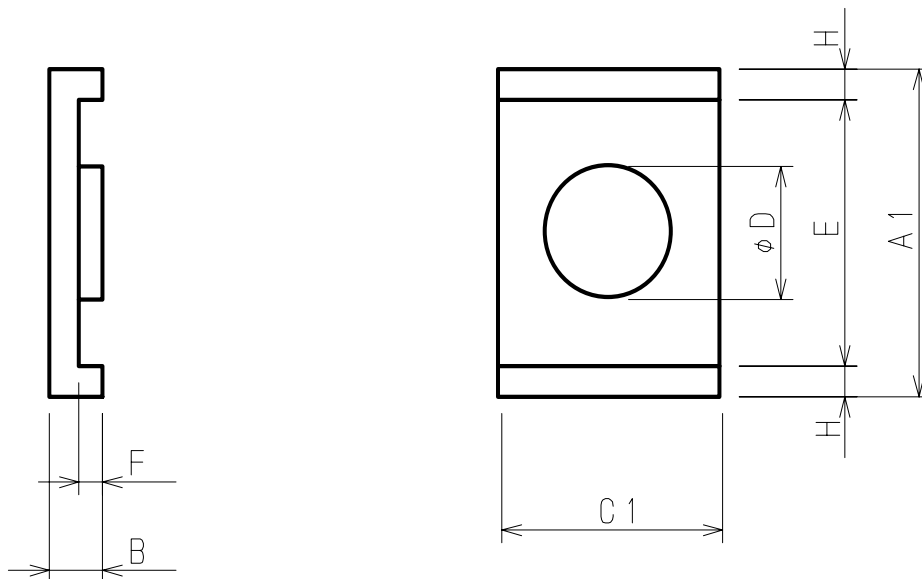

TDK CORPORATION

MH&W International Corp, 14 Leighton Place, Mahwah, NJ 07430
 Toll Free: 866-MHW-CORE, Email: salesm@mhw-intl.com