

P 11 × 7

Core

B65531

- In accordance with IEC 60133
- Pot cores are supplied in sets

Magnetic characteristics (per set)

	with center hole	without center hole	
Σ/A	1,0	0,92	mm ⁻¹
l_e	15,9	16,30	mm
A_e	15,9	17,70	mm ²
A_{min}	—	14,90	mm ²
V_e	252,0	289,00	mm ³

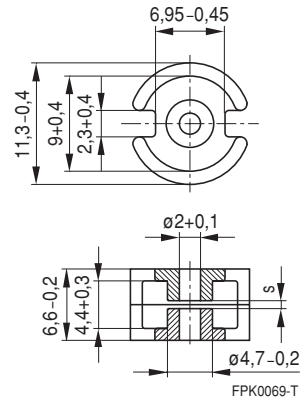

Approx. weight (per set)

m	1,7	1,8	g

Gapped

Material	A_L value nH	s approx. mm	μ_e	Ordering code ¹⁾ -D with center hole -T with threaded sleeve
K1	25 ± 3 %	1,00	20	B65531-D25-A1
	40 ± 3 %	0,41	32	B65531-D40-A1
M33	40 ± 3 %	0,64	32	B65531-D40-A33
	63 ± 3 %	0,38	50	B65531-D63-A33
N48	100 ± 3 %	0,20	80	B65531-D100-A48
	160 ± 3 %	0,10	127	B65531-+160-A48
	250 ± 3 %	0,06	199	B65531-+250-A48
	400 ± 5 %	0,03	318	B65531-D400-J48

Ungapped

Material	A_L value nH	μ_e	A_{L1min} nH	P_V W/set	Ordering code -D with center hole -W w/o center hole
M33	780 + 30/- 20 %	620			B65531-D-R33
N26	1800 + 30/- 20 %	1430			B65531-D-R26
N30	3500 + 30/- 20 %	2560			B65531-W-R30
T38	7000 + 40/- 30 %	5120			B65531-W-Y38
N87	2000 + 30/- 20 %	1460	1250	< 0,12 (200 mT, 100 kHz, 100 °C)	B65531-W-R87

1) Replace the + by the code letter "D" or "T" for the required version.

Coil former

Standard: to IEC 60133

Material: GFR polyterephthalate (UL 94 V-0, insulation class to IEC 60085:

F \triangleq max. operating temperature 155 °C), color code black

Winding: see "Processing Notes", page 155

Insulating washer 1 between core and coil former

- For tolerance compensation and for insulation
- Polycarbonate spring washer (UL 94 V-0, insulation class to IEC 60085: E \triangleq 120°C), 0,04 mm thick

Coil former				Ordering code
Sections	A_N mm ²	l_N mm	A_R value $\mu\Omega$	
1	4,2	22	180	B65532-B-T1
Insulating washer 1 (reel packing, PU = 1 reel)				B65532-A5000

Coil former

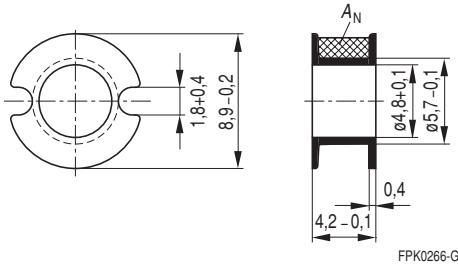

Insulating washer 1

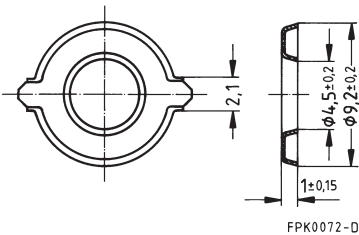

Mounting assembly for printed circuit boards

- The set comprises a terminal carrier and a yoke
- For snap-in connection

Terminal carrier

- With thread for the adjusting screw (to be combined with core version "D")

Material: GFR polyterephthalate (UL 94 V-0, insulation class to IEC 60085:

F \triangleq max. operating temperature 155 °C), color code black

Solderability: to IEC 60068-2-20, test Ta, method 1 (aging 3): 235 °C, 2 s

Resistance to soldering heat: to IEC 60068-2-20, test Tb, method 1B: 350 °C, 3,5 s

Yoke

Spring yoke, made of tinned nickel silver (0,25 mm), with ground terminal

Complete mounting assembly
(4 solder terminals)
Ordering code: B65535-B2

Complete mounting assembly
(8 solder terminals)
Ordering code: B65535-B3

4 solder terminals

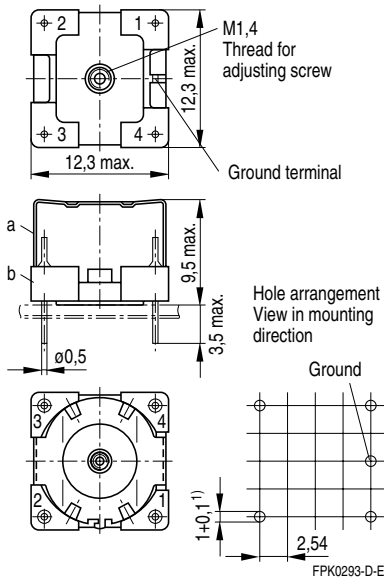

8 solder terminals

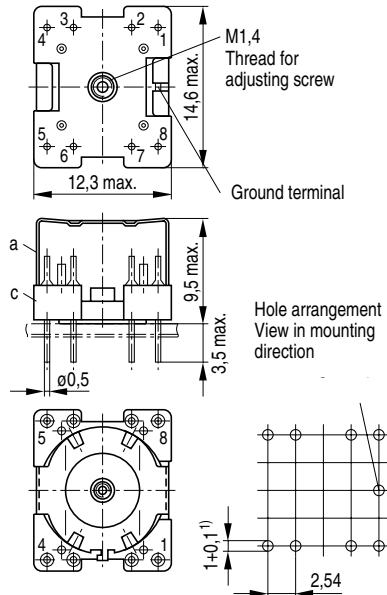

- 1) 1,3 hole also permissible
- a) Yoke
- b) Terminal carrier with 4 solder terminals
- c) Terminal carrier with 8 solder terminals

Adjusting screw

- Tube core with thread and core brake made of GFR polyterephthalate
- Plastic **adjusting screwdriver** (not shown)
- Plastic **handle** for adjusting screwdriver (not shown)

Core P 11 × 7		Adjusting screw			Min. adjusting range %	Ordering code
Material	A _L value nH	Tube core ∅ × length mm	Material	Color code		
K 1	25	1,81 × 2,0	K 1	yellow	30	B65539-C1003-X1
	40					
M 33	40	1,81 × 2,0	Si 1	black	17	B65539-C1003-X101
	63					
N 48	100	1,81 × 2,0	K 1	yellow	17	B65539-C1003-X1
	160	1,81 × 2,7	N 22	red	16	B65539-C1002-X22
	250					
Adjusting screwdriver						B63399-B4
Handle						B63399-B5

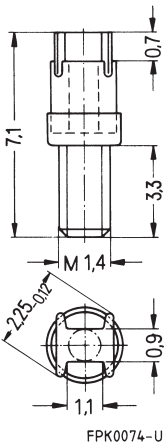
Adjusting screw

Herausgegeben von EPCOS AG

Marketing Kommunikation, Postfach 80 17 09, 81617 München, DEUTSCHLAND

© EPCOS AG 2000. Alle Rechte vorbehalten. Vervielfältigung, Veröffentlichung, Verbreitung und Verwertung dieser Broschüre und ihres Inhalts ohne ausdrückliche Genehmigung der EPCOS AG nicht gestattet.

Mit den Angaben in dieser Broschüre werden die Bauelemente spezifiziert, keine Eigenschaften zugesichert. Bestellungen unterliegen den vom ZVEI empfohlenen Allgemeinen Lieferbedingungen für Erzeugnisse und Leistungen der Elektroindustrie, soweit nichts anderes vereinbart wird.

Diese Broschüre ersetzt die vorige Ausgabe.

Fragen über Technik, Preise und Liefermöglichkeiten richten Sie bitte an den Ihnen nächstgelegenen Vertrieb der EPCOS AG oder an unsere Vertriebsgesellschaften im Ausland.

Bauelemente können aufgrund technischer Erfordernisse Gefahrstoffe enthalten. Auskünfte darüber bitten wir unter Angabe des betreffenden Typs ebenfalls über die zuständige Vertriebsgesellschaft einzuholen.

Published by EPCOS AG

Marketing Communications, P.O. Box 80 17 09, 81617 Munich, GERMANY

© EPCOS AG 2000. All Rights Reserved. Reproduction, publication and dissemination of this brochure and the information contained therein without EPCOS' prior express consent is prohibited.

The information contained in this brochure describes the type of component and shall not be considered as guaranteed characteristics. Purchase orders are subject to the General Conditions for the Supply of Products and Services of the Electrical and Electronics Industry recommended by the ZVEI (German Electrical and Electronic Manufacturers' Association), unless otherwise agreed.

This brochure replaces the previous edition.

For questions on technology, prices and delivery please contact the Sales Offices of EPCOS AG or the international Representatives.

Due to technical requirements components may contain dangerous substances. For information on the type in question please also contact one of our Sales Offices.