

- In accordance with IEC 61596
- For transformers featuring high inductance and low overall height
- For power applications
- EP cores are supplied in sets

Magnetic characteristics (per set)

$$\Sigma l/A = 0,51 \text{ mm}^{-1}$$

$$l_e = 40 \text{ mm}$$

$$A_e = 78 \text{ mm}^2$$

$$A_{\min} = 60 \text{ mm}^2$$

$$V_e = 3\,120 \text{ mm}^3$$

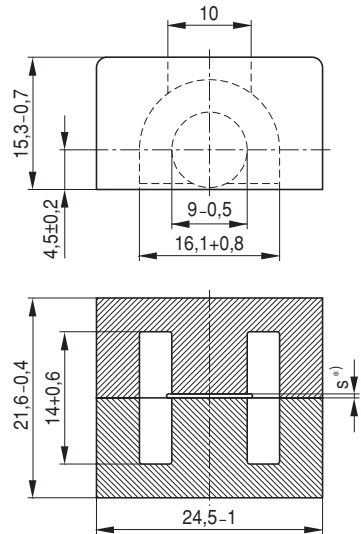
Approx. weight 27,5 g/set

^{s)} gapped (one-sided)

FEP0031-N

Gapped

Material	A_L value nH	s approx. mm	μ_e	Ordering code
N87	200 ± 3 %	0,20	134	B65847-A200-A87

Ungapped

Material	A_L value nH	μ_e	$A_{L1\min}$ nH	P_V W/set	Ordering code
N87	4000 + 30/- 20 %	1630	2200	< 1,2 (200 mT, 100 kHz, 100 °C)	B65847-A-R87
N26	3500 + 30/- 20 %	1430			B65847-A-R26
N30	6700 + 30/- 20 %	2720			B65847-A-R30
T65	10200 + 30/- 20 %	4160			B65847-A-R65
T38	18700 + 40/- 30 %	7590			B65847-A-Y38

Coil former

Material: GFR thermosetting plastic (UL 94 V-0, insulation class to IEC 60085: F \geq max. operating temperature 155 °C), color code green
 Solderability: to IEC 60068-2-20, test Ta, method 1 (aging 3): 235 °C, 2 s
 Resistance to soldering heat: to IEC 60068-2-20, test Tb, method 1B: 350 °C, 3,5 s
 Winding: see "Processing Notes", page 156
 Squared pins

Sections	A_N mm ²	l_N mm	A_R value $\mu\Omega$	Terminals	Ordering code
1	35,4	40,6	39,5	10	B65848-D1010-D1

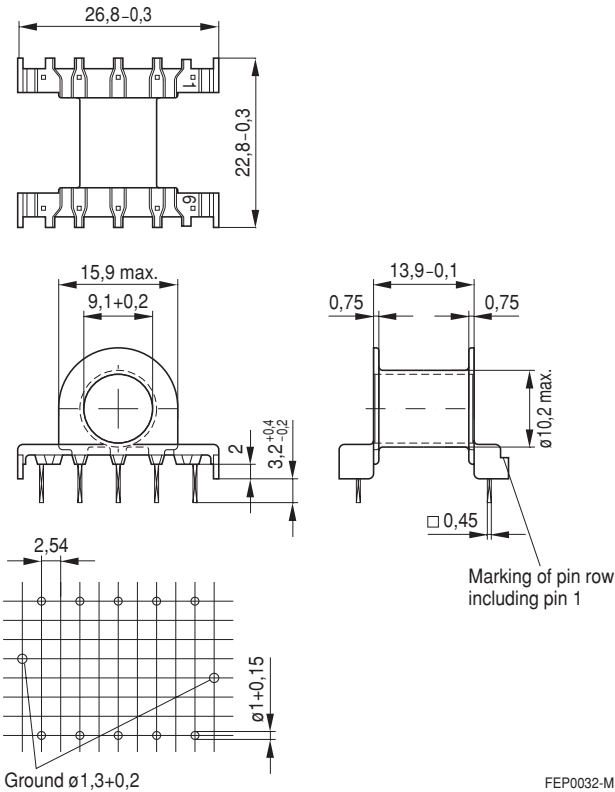

FEP0032-M

Mounting assembly

The set comprises a yoke and a clamp

Yoke

Made of nickel silver (0,4 mm) with ground terminal (tinned)

Clamp

Spring clamp, made of nickel silver (0,4 mm)

	Ordering code
Complete mounting assembly	B65848-A2000

Yoke

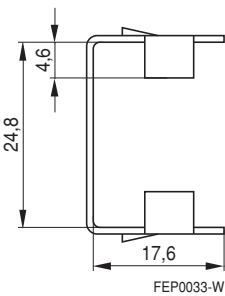
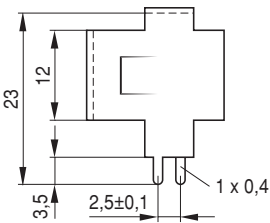

Clamp

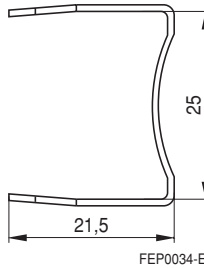
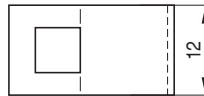

Herausgegeben von EPCOS AG

Marketing Kommunikation, Postfach 80 17 09, 81617 München, DEUTSCHLAND

© EPCOS AG 2000. Alle Rechte vorbehalten. Vervielfältigung, Veröffentlichung, Verbreitung und Verwertung dieser Broschüre und ihres Inhalts ohne ausdrückliche Genehmigung der EPCOS AG nicht gestattet.

Mit den Angaben in dieser Broschüre werden die Bauelemente spezifiziert, keine Eigenschaften zugesichert. Bestellungen unterliegen den vom ZVEI empfohlenen Allgemeinen Lieferbedingungen für Erzeugnisse und Leistungen der Elektroindustrie, soweit nichts anderes vereinbart wird.

Diese Broschüre ersetzt die vorige Ausgabe.

Fragen über Technik, Preise und Liefermöglichkeiten richten Sie bitte an den Ihnen nächstgelegenen Vertrieb der EPCOS AG oder an unsere Vertriebsgesellschaften im Ausland.

Bauelemente können aufgrund technischer Erfordernisse Gefahrstoffe enthalten. Auskünfte darüber bitten wir unter Angabe des betreffenden Typs ebenfalls über die zuständige Vertriebsgesellschaft einzuholen.

Published by EPCOS AG

Marketing Communications, P.O. Box 80 17 09, 81617 Munich, GERMANY

© EPCOS AG 2000. All Rights Reserved. Reproduction, publication and dissemination of this brochure and the information contained therein without EPCOS' prior express consent is prohibited.

The information contained in this brochure describes the type of component and shall not be considered as guaranteed characteristics. Purchase orders are subject to the General Conditions for the Supply of Products and Services of the Electrical and Electronics Industry recommended by the ZVEI (German Electrical and Electronic Manufacturers' Association), unless otherwise agreed.

This brochure replaces the previous edition.

For questions on technology, prices and delivery please contact the Sales Offices of EPCOS AG or the international Representatives.

Due to technical requirements components may contain dangerous substances. For information on the type in question please also contact one of our Sales Offices.