

OD330

OD 33.02mm / 1.300inch

ID 19.94mm
HT 10.67mm

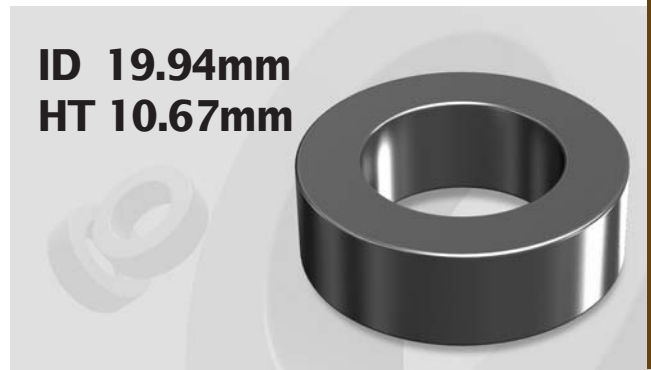

Core Dimensions

		OD(max)	ID(min)	HT(max)
Before coating	(mm)	33.02	19.94	10.67
	(inch)	1.300	0.785	0.420
After coating (Epoxy)	(mm)	33.83	19.30	11.61
	(inch)	1.332	0.760	0.457

Magnetic Dimensions

Cross Section (A)	Path Length (ℓ)	Window Area (Wa)	Volume (V)
00.672cm ²	8.15cm	2.93cm ²	5.4768cm ³
0.1042in ²	3.21in	577,600cmil	0.3345in ³

Winding Information

AWG Wire No.	Single Layer Dia(cm)	Turn	Rdc,Ω	AWG Wire No.	Single Layer Dia(cm)	Turn	Rdc,Ω
12	0.213	23	0.00517	21	0.0785	66	0.105
13	0.190	26	0.00722	22	0.0701	74	0.148
14	0.171	29	0.0100	23	0.0632	82	0.206
15	0.153	32	0.0140	24	0.0566	92	0.289
16	0.137	37	0.0197	25	0.0505	103	0.406
17	0.122	41	0.0274	26	0.0452	115	0.572
18	0.109	46	0.0384	27	0.0409	128	0.794
19	0.0980	52	0.0538	28	0.0366	143	1.12
20	0.0879	58	0.0750	29	0.0330	159	1.54

Single layer winding with 1 inch leads

Available Cores

MPP	Part No.			AL (nH/N ²)	Perm. (μ)
	High Flux	Sendust	Mega Flux®		
CM330026	CH330026	CS330026	CK330026	28	26
CM330060	CH330060	CS330060	CK330060	61	60
-	-	CS330075	CK330075	76	75
-	-	CS330090	CK330090	91	90
CM330125	CH330125	CS330125	-	127	125
CM330147	CH330147	-	-	150	147
CM330160	CH330160	-	-	163	160
CM330173	-	-	-	176	173
-	-	-	-	203	200

AL vs NI Curve (60μ, 125μ)

