

BNF Series EMI Clamp-on Cable Filter

BNF-1528 Cable Filter

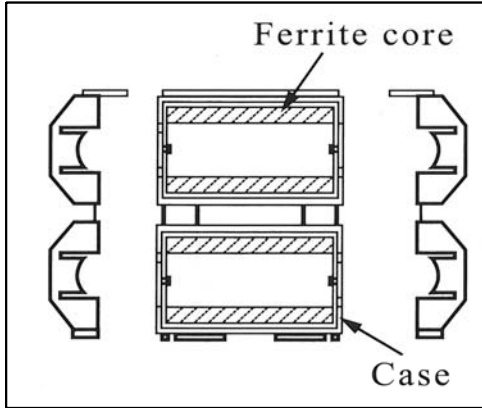

A (max)	22	mm
	0.866	in
B (min)	7.3	mm
	0.287	in
C (max)	37	mm
	1.457	in
D (max)	15.5	mm
	0.610	in
E (min)	4	mm
	0.157	in
Cable Diameter (max)	7	mm
	0.276	in
10 MHz	60	Ω
25 MHz	90	Ω
100 MHz	180	Ω

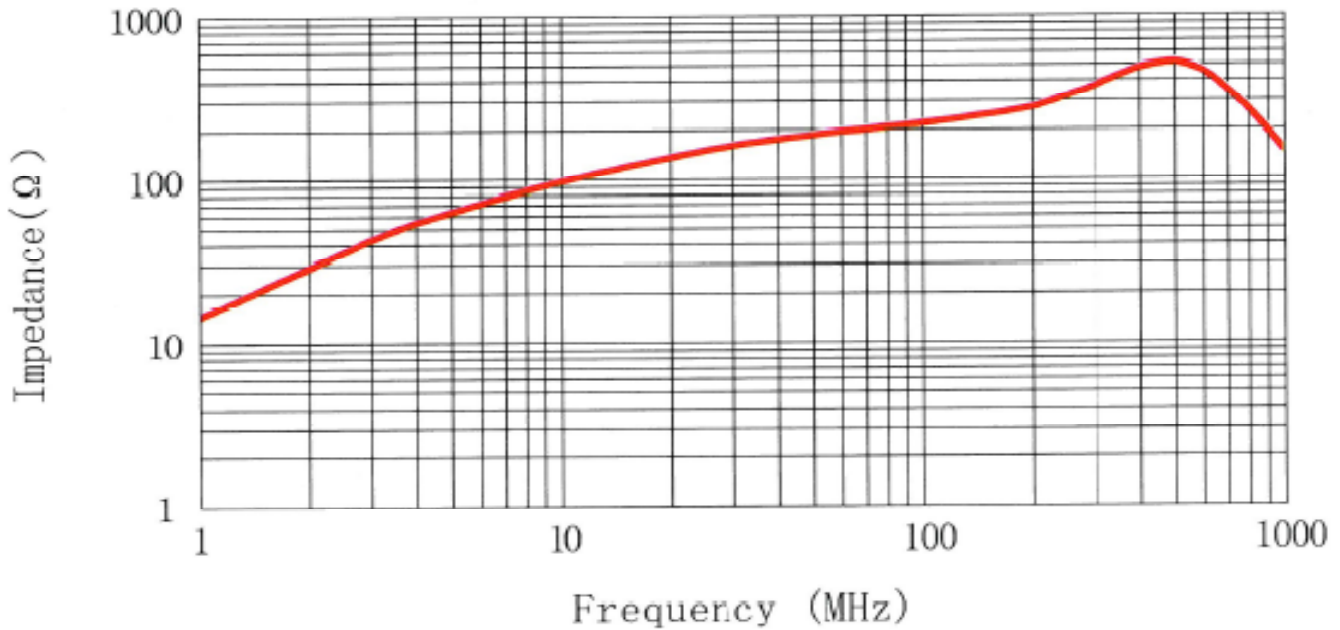
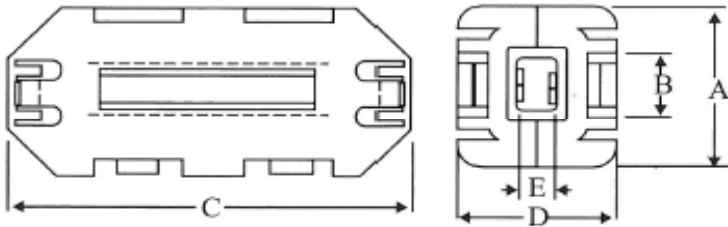

Distributed By

MH&W International Corp

14 Leighton Place, Mahwah, NJ 07430

Phone: 201-891-8800 - Toll Free: 866-MHW-CORE

Email: salesm@mhw-intl.com WEB: www.mhw-intl.com