

ACME



Issued Jun. 2013



ACME Electronics Corporation
越峯電子材料股份有限公司



ISO 9001 : 2008



ISO 14001 : 2004



QC 080000 : 2005



TS 16949 : 2009

<http://www.acme-ferrite.com.tw>



Our Company

ACME Electronics Corporation, a subsidiary of public listed company, USI Corporation, Taiwan is one of the world's leading manufacturers of soft ferrite products for the electronics industry.

Incorporated in 1991 and listed in the Taiwan OTC Securities Market in February, 2005, ACME has her headquarters in Nei-Hu District, Taipei, Taiwan and 4 manufacturing facilities in Kuan-Yin Industrial District, Taoyuan County, Taiwan; Ipoh, Perak, Malaysia; Kunshan City, Jiangsu Province and Zengcheng City, Guangdong Province in China.



Headquarter of USI Group, Taipei

Our Products

At ACME, we manufacture a very wide range of Manganese-Zinc and Nickel-Zinc soft ferrite products in different shapes and sizes. These products are used for the manufacture of chokes, inductors, filters, transformers, antennas and other components and devices that are applied in the communication, lighting, alternative energy, automotive, consumer and industrial electronics. ACME's products are used by leading manufacturers of these components and devices worldwide.

Our History

1991 – ACME Electronics Corporation, Taiwan was incorporated

1994 – Built the first manufacturing facility in Kuan-Yin District, Taoyuan County, Taiwan

2000 – Incorporated ACME Electronics (Kunshan) Co. Ltd., China and built a modern manufacturing facility to service the market in Northern and Eastern China. This factory had been expanded and equipped with the latest machinery and equipment. It now has a capacity of 6,800 metric tonnes a year.

2005 – Incorporated ACME Electronics (Guangzhou) Co. Ltd., China. Located in Zengcheng City, this new and well equipped facility has a capacity of 6,300 metric tonnes a year and services the market in Southern China.

2009 – Acquired ACME Ferrite Products Sdn. Bhd., Malaysia. Located in Ipoh, Perak, ACME Malaysia is a leading Nickel-Zinc soft ferrite manufacturer that specialises in ferrite products for the automotive industry. This facility has a capacity of 1,200 metric tonnes a year.



Kuan-Yin Factory, Taiwan



AGGRESSIVELY
COMMITTED TO
MANUFACTURING
EXCELLENCE



Contents

Symbols and Definitions	2
Material Characteristics	7
<i>Mn-Zn Ferrite</i>	
Low Loss Materials:P4, P41, P42, P48	7
Wide Temperature Low Loss Materials:P45, P46, P47	8
Low Loss and High Bs Material:P49	8
Low Loss Materials:P5, P51, P52	9
High Frequency Low Loss Material:P6	9
High Permeability Materials:A05, A062, A07, A10, A102, A121, A151	10
Telecom High Permeability Materials:N07, N10, A043, A061	11
THD High Permeability Material:A101	12
Telecom High Bs Material:N42	12
Sensor and Telecom Filter Materials:N4, N43	13
EMI-Suppression Materials:N5, N51	13
<i>Ni-Zn Ferrite</i>	
EMI-Suppression Materials:K05, K07, K08, K10, K15, K20	14
Low Loss Materials:K081, K12	14
High Bs Materials:B25, B30, B40, B45, B60, B90	15
Rod Core Materials:H2, H3, H3A, H3B, H4, H5, H5M, H5R	15
Wide Temperature Antenna Materials:F50, F51	16
Low μ Materials:L1, L2, L3, L4, L5, L6	16
Product Specifications	76
<i>Mn-Zn Ferrite</i>	
EFD Cores	76
EPC Cores	84
CI Cores (Power Inductor)	86
DR Cores	90
R Cores	92
ZT/I Cores	93
SC/UT Cores	94
ER Cores	96
ERX Cores	102
EPO Cores	103
EP Cores	104
CUT Cores	106
POT Cores	108
RM/LM Cores	110
PEI Cores (Planner Core)	112
PQ Cores	114
EE/EEL Cores	116
EF Cores	122
ET Cores	123
UU Cores	124
RF Cores	126
UI Cores	127
UT Cores	128
RID Cores	129
T Cores	130
RH Cores	150
<i>Ni-Zn Ferrite</i>	
R Cores	152
SC Cores	153
DR Cores	154
SRI/RI Cores	156
SDR Cores	158
RID Cores	160
R Cores (Multi Aperture)	161
AR Cores	162
FC Cores	163
I Cores (Plates)	164
I Cores	165
ET Cores	166
T Cores (EMI Suppression)	167
T Cores	168
RH Cores	172

INTRODUCTION TO FERRITES

Ferrite is categorized as electroceramics with ferrimagnets properties.

Ferrite exhibits ferrimagnetism due to the super exchange interaction between electrons of metal and oxygen ions. The opposite spins in ferrite results in lowering of magnetization compared to ferromagnetic metals where the spins are parallel. Due to the intrinsic atomic level interaction between oxygen and metal ions, ferrite has higher resistivity compared to ferromagnetic metals. This enables the ferrite to find application at higher frequencies and makes it technologically very valuable.

The chemical formula of ferrite is generally expressed as $MeFe_2O_4$. Where Me represents a divalent metal ion. (e.g. Fe^{2+} , Ni^{2+} , Mn^{2+} , Mg^{2+} , Co^{2+} , Zn^{2+} , Cu^{2+} etc). The crystal lattice of ferrite is spinel. Most important commercial derivatives of these ferrites are Zn^{2+} substituted Ni and Mn ferrite represented as $NiZnFe_2O_4$ and $MnZnFe_2O_4$ respectively. Major difference among these two ferrites is in their resistivity.

Ferrite Crystal:

The magnetic property of ferrite is the manifestation of nature of ions and their relative lattice position. Ferrite exists in spinel lattice structure. Metal ions are located at octahedral and tetrahedral positions. Fe^{2+} , Ni^{2+} , Mn^{2+} etc ions prefer to occupy the octahedral sites and Fe^{3+} and Zn^{2+} prefer tetrahedral sites. NiZn ferrite and MnZn ferrites has inverse spinel structure where the part of the B atoms occupies in the tetrahedral site and A atom occupy the Octahedral site. Depends on composition and process conditions such as sintering temperature and atmosphere, the lattice site occupancy changes, leading to the change in magnetic and electrical properties. This show that in ferrite manufacturing both composition and process conditions are very critical to get the required quality.

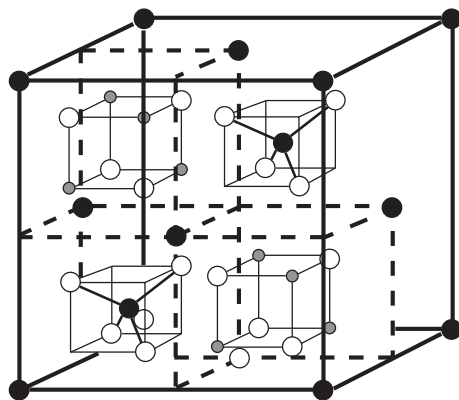

- Oxygen
- B-atoms octahedral sites
- A-atoms tetrahedral sites

Ferrimagnetism:

Ferrites exhibits ferrimagnetism. This means there is net magnetic moment in molecular level as a result of electronic interaction between Metal and oxygen ions called super exchange. In a bulk ferrite, there are domains called Weiss Domains in which all these molecular magnets are aligned in one direction. Domain wall separates different domains aligned in random directions and in presence of an external magnetic field these moments can be forced to align in one direction. Some energy has to be spent for this process and the magnetization always lags behind the magnetizing field and results in a magnetization loop. It is called as B-H Loop.

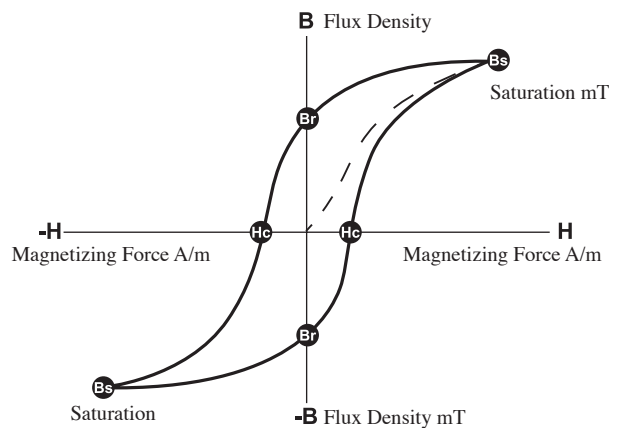

MAGNETIC PROPERTIES

Some of the important features of NiZn ferrite are described here in order to give a glimpse of the magnetic properties to our valued customer.

1. B-H HYSTERISI LOOP

A non-magnetized Ferrite when subjected to an AC magnetic field creates a loop of above pattern. At very low field, the BH relation is reversible and on higher fields the relation becomes

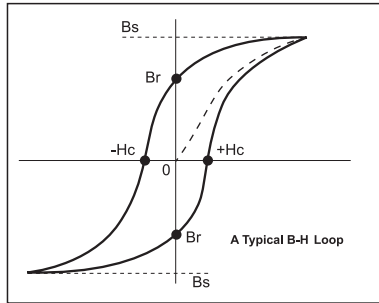

non-linear and non-reversible. Saturation magnetization (Bs) represents the saturation limit of flux density and Remanence (Br) is the residual flux even after the withdrawal of the inducing field. Coercivity (Hc) is the magnetic field required in the opposite direction to demagnetize the ferrite. The internal resistance imposed by anisotropy and other pinning center causes the delay in magnetization. The energy consumed to overcome this resistance is indicated by the area of the BH loop and is called hysteresis loss.

Ferrite cores are manufactured as per customer requirements and a wide range of products are available with different sizes and shapes. Correct materials are to be selected to make finished ferrite to suit all the customer requirements. The material properties are defined on a standard toroid. These material properties are used as a guideline to manufacture the right component.

2. PERMEABILITY

Most significant property of ferrite, which determines its performance, is the permeability and its response to external factors like Temperature, Frequency and Bias field. Permeability is the ratio of magnetic flux density (B) to the magnetic field causing the flux generation (H). In simple terms the 'B' is related to 'H' by $B = \mu_o H$ where μ_o is the permeability of vacuum, $4\pi \times 10^{-7}$ H/m.

Initial permeability of ferrite material is defined by

$$\mu_i = \frac{1}{\mu_o} \frac{\Delta B}{\Delta H} \quad \text{limit } H \longrightarrow 0$$

Initial permeability is measured on toroidal cores at the very low applied field. The flux density generated may be less than 0.1mT.

Initial permeability is calculated from the measured value of inductance (L) and calculated value of core factor C_1 using the formula

$$\mu_i = \frac{L \cdot C_1 \cdot 10^{-6}}{\mu_o \cdot N^2}$$

L in nH

$$\mu_o = 4\pi \times 10^{-7} \text{ H/m}$$

N = Number of turns

$$C_1 = \sum \frac{l_e}{A_e} \quad \begin{matrix} l_e = \text{the magnetic patch length} \\ A_e = \text{the sectional core Area} \end{matrix}$$

3. MAGNETIC FLUX DENSITY (B)

Ferrite when subjected to a magnetizing field induce magnetic flux (Φ , Webster) and the flux per unit area is the flux density (B, Tesla). As Tesla is a larger unit, a smaller unit mT ($=10^{-6}$ T) is used for all practical applications. Flux density is the product of permeability and applied field.

$$B = \mu_o \mu H$$

μ_o is the permeability of vacuum

μ is the permeability of the ferrite material

4. EFFECTIVE PERMEABILITY

Purposefully, air gap is introduced in the ferrite core for technical benefits. The shearing of B-H loop helps to increase the saturation limit to the core. The permeability of gapped core (μ_e) reduces as a function of the air gap.

$$\mu_e = \frac{\mu_i}{1 + \frac{\mu_i G}{l_e}}$$

5. AMPLITUDE PERMEABILITY

It is the ratio of the flux density and the applied field at higher field in the absence of DC bias field.

$$\mu_a = \frac{1}{\mu_o} \frac{B}{H}$$

6. INCREMENTAL PERMEABILITY

There are many application conditions where DC bias is applied. The incremental permeability (μ_Δ) is that observed when an ac field is superimposed with a DC field.

$$\mu_\Delta = \frac{1}{\mu_o} \frac{\Delta B}{\Delta H} \quad \text{under } H_{dc}$$

7. DISACCOMMODATION FACTOR (d)

This represents the time stability of permeability. The decrease in Permeability is almost proportional to the log (Time).

$$d = (\mu_1 - \mu_2) / \mu_i \log_{10} t_2 / t_1$$

And disaccommodation factor is defined as

$$D. F = (\mu_1 - \mu_2) / \mu_{i2} \log_{10} t_2 / t_1$$

8. INDUCTANCE & INDUCTANCE FACTOR

Inductance is the property of an inductor to induce emf when there is a change in current. It is also the flux linkage to unit current. The unit of inductance in Henry.

- L = N Φ/I Henry
- Where N = Number of turns
- I = Current in Amp.
- Φ = Flux in Webster

Inductance is the property of a conductor or a circuit, which resist the change in current. Hence, it causes current changes to drag behind voltage changes. An inductor stores the energy in the form magnetic field.

Inductance is proportional to square of number of turns and the proportionally constant is called inductance factor (A_L) ie,

$$L = A_L N^2 \text{ OR } A_L = L/N^2$$

9. Loss angle:

Magnetic loss is expressed as loss tangent (tan δ) and the contribution comes from inductive (reactive, ωL_s) and resistive, R_s. tan δ is the loss angle i.e., the angle between the Flux (B) and Applied field (H).

$$\tan \delta = \omega L_s / R_s$$

There is a direct relation between loss angle and imaginary (μ'') and real(μ') part of complex permeability as

$$\tan \delta = \mu_s'' / \mu_s'$$

Loss factor is defined as the ratio of loss angle to initial permeability. This is inverse of Q- factor.

10. Q- factor:

Quality factor is inverse of loss factor, tan δ/μ_i. NiZn ferrite is capable of giving higher Q factor at higher resistivity compared to MnZn ferrite. Q is sensitive to not only the chemical composition but the post sintered handling also. Proximity to

strong magnetic field or mechanical stress can reduce Q value of ferrite.

11. Complex permeability:

In a series inductive circuit, the reactive and resistive components are related to complex permeability by:

$$\mu'' = R_s / \omega L_o \text{ and } \mu' = L_s / L_o$$

Where μ'' is the imaginary component of the series complex permeability and μ' is the real component of the series complex permeability. The graph below shows the behaviour of initial permeability(real and imaginary) at different frequencies.

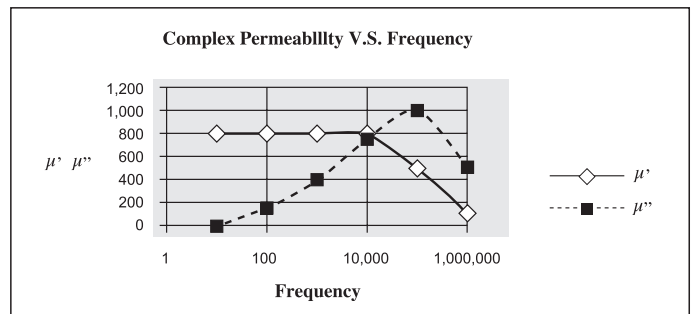

12. Impedance:

Impedance is the combined effect of capacitance, inductance, and resistance on a signal. According to Ohm's law, voltage is the product of current and resistance at a given frequency. Impedance is a measure of resistance to electrical current flow when a voltage is moved across it. Impedance is measured in ohms and is the ratio of voltage to the flow of current.

For a series circuit, the Reactance is

$$X = j \omega L_s$$

and Resistance is R_s then the impedance,

$$Z = j \omega L_s + R_s$$

The impedance also be expressed in terms of complex permeability as

$$Z = j \omega L_s (\mu_s' - j\mu_s'')$$

In low frequencies, the inductance is prominent and at higher frequencies, the Resistance.

To have a high Q component, the resistance part must be low and inductive part must be high. At higher frequencies, these inductors act not as inductors but as resistors dissipating the noises in to heat and perform as a noise suppressor.

Hence, in the selection of ferrite for EMI suppressor, the impedance in the selected noise band is important. Thus the impedance can be translated in to magnetic characteristics separating out the real and imaginary part. Another expression for impedance is

$$Z = \sqrt{(R^2 + X^2)} = \omega L_o \sqrt{(\mu'^2 + j\mu''^2)}$$

Where $L_o = \mu_o N^2 A_e/l_e$

One advantage of this equation is that the impedance is proportional to the square of the number of winding (N) for a same product.

13. Resistivity:

Resistivity of Ferrites depends on its chemistry. NiZn ferrite has a resistivity of more than 1 MΩ-m and that of MnZn ferrite is in the range of 1 to 100Ω-m. Due to the higher resistivity of NiZn ferrite, eddy current losses are at minimum and makes it useful at higher frequency applications. The DC resistivities reported are measured at room temperature (25°C). The resistivity reduces at higher frequencies as the grain boundaries get short-circuited due to electron hopping.

14. CORE CONSTANTS

For a non-uniform core, a hypothetical toroid equivalent can be calculated using:

$$C_1 = \Sigma l/A \quad (\text{mm}^{-1}) \quad C_2 = \Sigma l/A^2 \quad (\text{mm}^{-3})$$

And effective parameters are calculated from C_1 & C_2

$$\text{Effective Area, } A_e = C_1 / C_2 \quad \text{mm}^2$$

A_e of ferrite is inversely proportional to saturation current and directly proportional to attenuation.

$$\begin{aligned} \text{Effective path length, } L_e &= C_1^2 / C_2 \quad \text{mm} \\ \text{Effective volume, } V_e &= C_1^3 / C_2^2 \quad \text{mm}^3 \end{aligned}$$

C_1 is also used to calculate inductance of a core configuration through

$$L = \frac{4\pi N^2 10^{-9}}{C_1} \quad \text{H}$$

For a toroid,

$$C_1 = (2\pi / h) \log_e (r_2/r_1)$$

Where r_1 = internal radius of toroid
 r_2 = external radius of toroid
 h = height of toroid

15. DC bias conditions:

Performance of ferrite as EMI filter under DC bias conditions is considered as one of the significant parameters of ferrite quality. Very large lossy impedance is achieved in ferrite when it is operated under bias condition creating less than the saturating magnetic field. Once saturated, the permeability becomes one (equal to that of vacuum) and this condition is not good for any ferrite applications. The bias field reduces the impedance of ferrite and best impedance is achieved in zero DC bias conditions. Technically the bias conditions are important because there are many EMI suppression applications under DC field. Hence, ferrite with higher saturation magnetization (B_s) is required to suit extreme bias conditions. ACME manufactures high B_s MnZn/NiZn ferrite material for this purpose. Increase in mass of ferrite component can also compensate this requirement.

16. Temperature dependence

Permeability increases with temperature to a maximum and drops suddenly after a certain temperature. This temperature is defined as Curie Temperature (T_c). Ferrite becomes paramagnetic after this temperature due to the complete disordering of magnetic moments caused by thermal energy.

T_c is normally controlled by the chemistry of ferrite. Thus each grade has its own T_c value and higher the initial permeability, lower the T_c value.

Saturation flux density also decreases with temperature. This is again due to the thermal disordering of magnetic moments in ferrite. At T_c , the flux density reaches zero.

The change in permeability with temperature is quantitatively expressed as Temperature coefficient of permeability (TC). Temperature factor of permeability is given by:

$$\alpha_F = \Delta\mu_i / \mu_i^2 \Delta T$$

17. SELF RESONANT FREQUENCY

It is the frequency at which the distributed capacitance resonates with inductance. The inductor will act purely as a resistor at this condition and provide maximum impedance.

Ferrite Manufacturing Process:

Ferrite is manufactured by normal ceramic route. This involves Raw material mix in required molar ratios, calcination to get uniform physical properties, milling, compacting to the required shape, sintering and finishing. Most important factors affecting the final properties of ferrite are its chemistry and process conditions and both of these jointly control the microstructure formation, which has a major role on the magnetic and mechanical properties of ferrite.

Manufacturing flow sheet

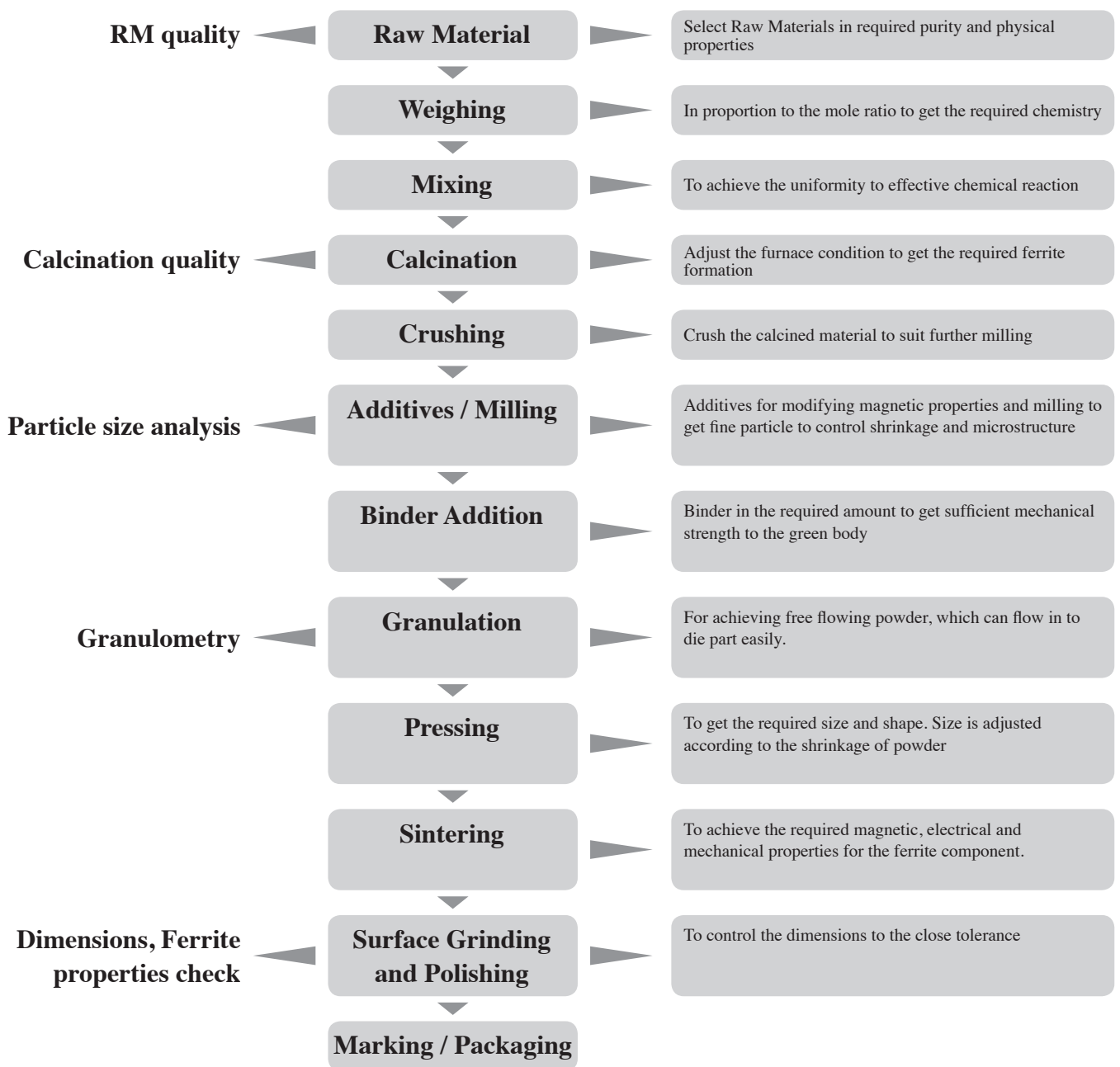

Material Characteristics (1)

	Symbol	Unit	Measuring Conditions			Low Loss Materials			
			Freq.	Flux den.	Temp.	P4	P41	P42	P48
Initial Permeability	μ_i		$\leq 10\text{kHz}$	0.25mT	25°C	2500 \pm 25%	2400 \pm 25%	1800 \pm 25%	2500 \pm 25%
Amplitude Permeability	μ_a		25kHz	200mT	25°C	> 4500	> 4500	> 5000	> 5000
					100°C	> 4500	> 4500	> 5000	> 5000
Power Loss	Pv	KW/m ³	25kHz	200mT	25°C	105	125	125	
					100°C	55	50	50	
			100kHz	200mT	25°C	700	650	750	550
					100°C	450	350	350	250
			300kHz	100mT	25°C	660	820	900	500
					100°C	430	500	500	300
			500kHz	50mT	25°C	380	400	450	250
					100°C	330	300	300	200
Saturation Flux Density	Bms	mT	10kHz	H = 1200A/m	25°C	480	495	520	515
					100°C	380	395	420	410
Remanence	Brms	mT	10kHz	H = 1200A/m	25°C	100	170	200	150
					100°C	70	70	70	60
Coercivity	Hc	A/m	10kHz	H = 1200A/m	25°C	10	11	12	13
					100°C	6	6	6	7
Hysteresis Material Constant	η_B	10 ⁻⁶ /mT	10kHz	1.5-3.0mT	25°C	< 1.2	< 1	< 1	< 1
Disaccommodation Factor	D _F	10 ⁻⁶	10kHz	< 0.25 mT	25°C	< 2	< 2	< 2	< 2
Curie Temperature	T _c	°C				220	230	240	220
Resistivity	ρ	Ωm				5.50	4.00	8.00	5.00
Density	d	g/cm ³				4.80	4.85	4.90	4.90

Note: Material characteristics are typical for a toroid core.

Product specification will differ from these data due to the influence of geometry and size.

Material Characteristics (2)

	Symbol	Unit	Measuring Conditions			Wide Temperature Low Loss Materials		
			Freq.	Flux den.	Temp.	P45	P46	P47
Initial Permeability	μ_i		$\leq 10\text{kHz}$	0.25mT	25°C	3100 \pm 25%	3300 \pm 25%	3000 \pm 25%
Amplitude Permeability	μ_a		25kHz	200mT	25°C	> 5000	> 4500	> 5000
					100°C	> 5000	> 4500	> 5000
Power Loss	Pv	KW/m ³	25kHz	200mT	25°C		60	
					100°C		60	
			100kHz	200mT	25°C	360	400	400
					100°C	260	400	350
			300kHz	100mT	25°C	350	400	350
					100°C	300	400	350
500kHz	50mT	25°C	200	230	230			
		100°C	200	230	230			
Saturation Flux Density	Bms	mT	10kHz	H = 1200A/m	25°C	530	480	520
					100°C	405	370	420
Remanence	Brms	mT	10kHz	H = 1200A/m	25°C	80	100	85
					100°C	60	70	70
Coercivity	Hc	A/m	10kHz	H = 1200A/m	25°C	9.5	10	10
					100°C	6	6	7
Hysteresis Material Constant	ηB	10 ⁻⁶ /mT	10kHz	1.5-3.0mT	25°C	< 0.6	< 1.2	< 0.6
Disaccommodation Factor	D _F	10 ⁻⁶	10kHz	< 0.1 mT	25°C	< 1	< 2	< 1
Curie Temperature	T _c	°C				215	200	220
Resistivity	ρ	Ωm				5.00	5.00	5.00
Density	d	g/cm ³				4.90	4.80	4.90

Note: Material characteristics are typical for a toroid core.

Product specification will differ from these data due to the influence of geometry and size.

Material Characteristics (3)

	Symbol	Unit	Measuring Conditions			Low Loss and High Bs Material
			Freq.	Flux den.	Temp.	P49 NEW
Initial Permeability	μ_i		$\leq 10\text{kHz}$	0.25mT	25°C	1700 \pm 25%
Power Loss	Pv	KW/m ³	100kHz	200mT	25°C	800
					100°C	400
			500kHz	50mT	25°C	450
					100°C	220
Saturation Flux Density	Bms	mT	10kHz	H = 1200A/m	25°C	540
					100°C	460
Remanence	Brms	mT	10kHz	H = 1200A/m	25°C	280
					100°C	60
Coercivity	Hc	A/m	10kHz	H = 1200A/m	25°C	13
					100°C	7
Curie Temperature	T _c	°C	10kHz	<0.25mT		>280
Resistivity	ρ	Ωm				5.00
Density	d	g/cm ³				4.90

Note: Material characteristics are typical for a toroid core.

Product specification will differ from these data due to the influence of geometry and size.

Material Characteristics (4)

	Symbol	Unit	Measuring Conditions			Low Loss Materials				
			Freq.	Flux den.	Temp.	P5	P51	P52		
Initial Permeability	μ_i		≤ 10kHz	0.25mT	25°C	2000 ± 25%	1500 ± 25%	2000 ± 25%		
Amplitude Permeability	μ_a		25kHz	200mT	25°C	> 4000	> 2500	> 4000		
					100°C	> 4000	> 2500	> 4000		
Power Loss	Pv	KW/m ³	300kHz	100mT	25°C	600	410	510		
					100°C	450	310	450		
					500kHz	50mT	25°C	220	200	210
							100°C	250	100	140
			700kHz	50mT	25°C	600	300	410		
					100°C	550	250	400		
			1000kHz	50mT	25°C		600	1000		
					100°C		600	1000		
Saturation Flux Density	Bms	mT	10kHz	H = 1200A/m	25°C	470	490	500		
					100°C	350	400	400		
Remanence	Brms	mT	10kHz	H = 1200A/m	25°C	100	180	190		
					100°C	60	130	100		
Coercivity	Hc	A/m	10kHz	H = 1200A/m	25°C	12	30	21		
					100°C	8	25	18		
Hysteresis Material Constant	η_B	10 ⁻⁶ /mT	10kHz	1.5-3.0mT	25°C	< 1	< 1	< 1		
Disaccommodation Factor	D _F	10 ⁻⁶	10kHz	< 0.25 mT	25°C	< 2	< 2	< 2		
Curie Temperature	T _c	°C				220	250	250		
Resistivity	ρ	Ωm				6.40	12.00	6.50		
Density	d	g/cm ³				4.70	4.85	4.85		

Note: Material characteristics are typical for a toroid core.

Product specification will differ from these data due to the influence of geometry and size.

Material Characteristics (5)

	Symbol	Unit	Measuring Conditions			High Frequency Low Loss Material		
			Freq.	Flux den.	Temp.	P6		
Initial Permeability	μ_i		≤ 10kHz	0.25mT	25°C	900 ± 25%		
Amplitude Permeability	μ_a		25kHz	200mT	25°C	1700		
					100°C	1800		
Power Loss	Pv	KW/m ³	1MHz	50mT	25°C	250		
					100°C	150		
					3MHz	10mT	25°C	50
							100°C	50
			3MHz	30mT	25°C	600		
					100°C	500		
			5MHz	9mT	25°C	150		
					100°C	170		
Saturation Flux Density	Bms	mT	10kHz	H = 1200A/m	25°C	515		
					100°C	430		
Remanence	Brms	mT	10kHz	H = 1200A/m	25°C	250		
					100°C	160		
Coercivity	Hc	A/m	10kHz	H = 1200A/m	25°C	55		
					100°C	45		
Hysteresis Material Constant	η_B	10 ⁻⁶ /mT	10kHz	1.5-3.0mT	25°C	< 1		
Disaccommodation Factor	D _F	10 ⁻⁶	10kHz	< 0.25 mT	25°C	< 2		
Curie Temperature	T _c	°C				280		
Resistivity	ρ	Ωm				10.00		
Density	d	g/cm ³				4.80		

Note: Material characteristics are typical for a toroid core.

Product specification will differ from these data due to the influence of geometry and size.

Material Characteristics (6)

	Symbol	Unit	Measuring Conditions			High Permeability Materials		
			Freq.	Flux den.	Temp.	A05	A062 NEW	A07
Initial Permeability	μ_i		$\leq 10\text{kHz}$	0.25mT	25°C	5000 \pm 25%	6000 \pm 25%	7000 \pm 25%
Relative Loss Factor	$\tan\delta/\mu_i$	10 ⁻⁶	10kHz	< 0.25mT	25°C	< 4	< 10	< 8
			100kHz		25°C	< 15	< 30	< 30
Saturation Flux Density	B _{ms}	mT	10kHz	H = 1200A/m	25°C	440	460	400
					100°C	300	320	200
Remanence	Br _{ms}	mT	10kHz	H = 1200A/m	25°C	80	100	150
					100°C	90	80	110
Temperature Factor of Permeability	α_F	10 ⁻⁶ /°C	10kHz	< 0.25 mT	0 ~ 20°C	0 ~ 2	1 ~ 3	-1 ~ 1
					20 ~ 70°C	0 ~ 2	-1 ~ 1	-1 ~ 1
Hysteresis Material Constant	η_B	10 ⁻⁶ /mT	10kHz	1.5-3.0mT	25°C	< 0.8	< 0.5	< 1.2
Disaccommodation Factor	D _F	10 ⁻⁶	10kHz	< 0.25 mT	25°C	< 3	< 2	< 2
Curie Temperature	T _c	°C				140	160	130
Resistivity	ρ	Ωm				0.20	0.20	0.35
Density	d	g/cm ³				4.85	4.85	4.90

Note: Material characteristics are typical for a toroid core.

Product specification will differ from these data due to the influence of geometry and size.

Material Characteristics (7)

	Symbol	Unit	Measuring Conditions			High Permeability Materials			
			Freq.	Flux den.	Temp.	A10	A102	A121	A151
Initial Permeability	μ_i		$\leq 10\text{kHz}$	0.25mT	25°C	10000 \pm 30%	10000 \pm 30%	12000 \pm 30%	15000 \pm 30%
Relative Loss Factor	$\tan\delta/\mu_i$	10 ⁻⁶	10kHz	< 0.25mT	25°C	< 10	< 10	< 10	< 10
			100kHz		25°C	< 60	< 60	< 60	< 110
Saturation Flux Density	B _{ms}	mT	10kHz	H = 1200A/m	25°C	410	380	380	400
					100°C	210	180	180	170
Remanence	Br _{ms}	mT	10kHz	H = 1200A/m	25°C	140	95	130	220
					100°C	110	75	110	100
Temperature Factor of Permeability	α_F	10 ⁻⁶ /°C	10kHz	< 0.25 mT	0 ~ 20°C	0 ~ 1.5	-1 ~ 1	0 ~ 1.5	-1 ~ 1
					20 ~ 70°C	-0.5 ~ 1	-1 ~ 1	-0.5 ~ 1	-1 ~ 1
Hysteresis Material Constant	η_B	10 ⁻⁶ /mT	10kHz	1.5-3.0mT	25°C	< 0.5	< 1	< 0.5	< 0.5
Disaccommodation Factor	D _F	10 ⁻⁶	10kHz	< 0.25 mT	25°C	< 2	< 2	< 2	< 2
Curie Temperature	T _c	°C				130	120	110	110
Resistivity	ρ	Ωm				0.15	0.15	0.12	0.10
Density	d	g/cm ³				4.90	4.90	4.90	5.00

Remark: A102: Best impedance, and permeability v. s. frequency performance for 10,000 μ_2 materials.

Note: Material characteristics are typical for a toroid core.

Product specification will differ from these data due to the influence of geometry and size.

Material Characteristics (8)

	Symbol	Unit	Measuring Conditions			Telecom High Permeability Materials			
			Freq.	Flux den.	Temp.	N07	N10	A043	A061
Initial Permeability	$\mu'z$		$\leq 10\text{kHz}$	0.25mT	25°C	7000 ± 25%	10000 ± 25%	4500 ± 25%	6000 ± 25%
					-20°C		> 9000		
Relative Loss Factor	$\tan\delta/\mu'z$	10 ⁻⁶	10kHz	< 0.25mT	25°C	< 5	< 10	< 10	< 10
				100kHz	25°C	< 30	< 90	< 10	< 15
Saturation Flux Density	Bms	mT	10kHz	H = 1200A/m	25°C	400	380	460	460
					100°C	220	160	300	300
Remanence	Brms	mT	10kHz	H = 1200A/m	25°C	70	160	65	65
					100°C	60	110	60	60
Temperature Factor of Permeability	αF	10 ⁻⁶ /°C	10kHz	< 0.25 mT	0 ~ 20°C	-1 ~ 1	-1 ~ 0	1 ~ 2	1 ~ 2
					20 ~ 70°C	-1 ~ 1	-1 ~ 1	-1 ~ 1	-1 ~ 1
Hysteresis Material Constant	ηB	10 ⁻⁶ /mT	10kHz	1.5-3.0mT	25°C	< 0.2	< 0.5	< 0.5	< 0.5
Disaccommodation Factor	D _F	10 ⁻⁶	10kHz	< 0.25 mT	25°C	< 2	< 2	< 2	< 2
Curie Temperature	T _c	°C				130	100	160	160
Resistivity	ρ	Ωm				0.15	0.12	0.20	0.20
Density	d	g/cm ³				4.90	5.00	4.85	4.85

Note: Material characteristics are typical for a toroid core.

Product specification will differ from these data due to the influence of geometry and size.

Material Characteristics (9)

	Symbol	Unit	Measuring Conditions			THD High Permeability Material
			Freq.	Flux den.	Temp.	A101
Initial Permeability	μ_i		$\leq 10\text{kHz}$	0.25mT	25°C	10000 \pm 30%
Relative Loss Factor	$\tan\delta/\mu_i$	10^{-6}	10kHz	$< 0.25\text{mT}$	25°C	< 10
			100kHz		25°C	< 90
Saturation Flux Density	Bms	mT	10kHz	H = 1200A/m	25°C	400
					100°C	220
Remanence	Brms	mT	10kHz	H = 1200A/m	25°C	175
					100°C	125
Temperature Factor of Permeability	α_F	$10^{-6}/^\circ\text{C}$	10kHz	$< 0.25\text{ mT}$	0 ~ 20°C	-1 ~ 1
					20 ~ 70°C	-1 ~ 1
Hysteresis Material Constant	η_B	$10^{-6}/\text{mT}$	10kHz	1.5-3.0mT	25°C	< 0.2
Disaccommodation Factor	D_F	10^{-6}	10kHz	$< 0.25\text{ mT}$	25°C	< 2
Curie Temperature	Tc	°C				130
Resistivity	ρ	Ωm				0.15
Density	d	g/cm^3				4.90

Remark: Best THD performance for 10,000 μ_i materials.

Note: Material characteristics are typical for a toroid core.

Product specification will differ from these data due to the influence of geometry and size.

Material Characteristics (10)

	Symbol	Unit	Measuring Conditions			Telecom High Bs Material
			Freq.	Flux den.	Temp.	N42
Initial Permeability	μ_i		$\leq 10\text{kHz}$	0.25mT	25°C	3800 \pm 25%
Relative Loss Factor	$\tan\delta/\mu_i$	10^{-6}	10kHz	$< 0.25\text{mT}$	25°C	< 1.5
			100kHz		25°C	< 2.5
Saturation Flux Density	Bms	mT	10kHz	H = 1200A/m	25°C	530
					100°C	425
Remanence	Brms	mT	10kHz	H = 1200A/m	25°C	75
					100°C	250
Coercivity	Hc	A/m	10kHz	H = 1200A/m	25°C	7
					100°C	12
Temperature Factor of Permeability	α_F	$10^{-6}/^\circ\text{C}$	10kHz	$< 0.25\text{ mT}$	5 ~ 25°C	7 ~ 9
					25 ~ 55°C	$< -4 \sim -2$
Hysteresis Material Constant	η_B	$10^{-6}/\text{mT}$	10kHz	1.5-3.0mT	25°C	< 0.3
Curie Temperature	Tc	°C	10kHz	$< 0.25\text{ mT}$		250
Resistivity	ρ	Ωm				5.00
Density	d	g/cm^3				4.90

Note: Material characteristics are typical for a toroid core.

Product specification will differ from these data due to the influence of geometry and size.

Material Characteristics (11)

	Symbol	Unit	Measuring Conditions			Sensor and Telecom Filter Materials	
			Freq.	Flux den.	Temp.	N4	N43
Initial Permeability	μ_i		$\leq 10\text{kHz}$	0.25mT	25°C	2500 \pm 25%	750 \pm 25%
Relative Loss Factor	$\tan\delta/\mu_i$	10^{-6}	10kHz	$< 0.25\text{mT}$	25°C	< 7	< 60
			100kHz		25°C	< 3	< 15
Saturation Flux Density	Bms	mT	10kHz	H = 1200A/m	25°C	450	490
					100°C	320	400
Remanence	Brms	mT	10kHz	H = 1200A/m	25°C	90	240
					100°C	100	190
Coercivity	Hc	A/m	10kHz	H = 1200A/m	25°C	13	23
					100°C	11	18
Temperature Factor of Permeability	α_F	$10^{-6}/^\circ\text{C}$	10kHz	$< 0.25\text{ mT}$	5 ~ 25°C	< 1.3	< 2.2
					25 ~ 55°C	< 1.3	< 1.8
Hysteresis Material Constant	η_B	$10^{-6}/\text{mT}$	10kHz	1.5-3.0mT	25°C	< 0.6	$< 2.5^{(100\text{kHz})}$
Curie Temperature	Tc	°C	10kHz	$< 0.25\text{ mT}$		170	250
Resistivity	ρ	Ωm				7.50	2.00
Density	d	g/cm^3				4.70	4.70

Note: Material characteristics are typical for a toroid core.

Product specification will differ from these data due to the influence of geometry and size.

Material Characteristics (12)

	Symbol	Unit	Measuring Conditions			EMI-Suppression Materials	
			Freq.	Flux den.	Temp.	N5	N51
Initial Permeability	μ_i		$\leq 10\text{kHz}$	0.25mT	25°C	2000 \pm 25%	450 \pm 25%
Relative Loss Factor	$\tan\delta/\mu_i$	10^{-6}	10kHz	$< 0.25\text{mT}$	25°C	< 1.24	
			100kHz		25°C	< 23	
Saturation Flux Density	Bms	mT	10kHz	H = 1200A/m	25°C	370	363
					100°C	285	304
Remanence	Brms	mT	10kHz	H = 1200A/m	25°C	240	316
					100°C	140	250
Coercivity	Hc	A/m	10kHz	H = 1200A/m	25°C		70
					100°C		32
Temperature Factor of Permeability	α_F	$10^{-6}/^\circ\text{C}$	10kHz	$< 0.25\text{ mT}$	5 ~ 25°C	< 1.1	< 15
					25 ~ 55°C	< 5.8	< 15
Hysteresis Material Constant	η_B	$10^{-6}/\text{mT}$	10kHz	1.5-3.0mT	25°C	< 0.36	
Curie Temperature	Tc	°C	10kHz	$< 0.25\text{ mT}$		130	220
Resistivity	ρ	Ωm				140	10000
Density	d	g/cm^3				4.95	4.75

Note: Material characteristics are typical for a toroid core.

Product specification will differ from these data due to the influence of geometry and size.

Material Characteristics (13)

	Symbol	Unit	Measuring Conditions			EMI-Suppression Materials					
			Freq.	Flux den.	Temp.	K05	K07	K08	K10	K15	K20
Initial Permeability	μ_i		$\leq 10\text{kHz}$	0.25mT	25°C	500 ± 25%	700 ± 25%	800 ± 25%	1000 ± 25%	1500 ± 25%	2000 ± 25%
Saturation Flux Density	Bms	mT	1kHz	H = 1200A/m	25°C	380	350	350	355	330	300
Remanence	Brms	mT	1kHz	H = 1200A/m	25°C	260	195	185	250	200	150
Coercivity	Hc	A/m	1kHz	H = 1200A/m	25°C	80	45	29	17	11	10
Relative Loss Factor	$\tan\delta/\mu_i$	10 ⁻⁶	100kHz	< 0.25mT	25°C	100	18	16	11	11	11
Temperature Factor of Permeability	α_F	10 ⁻⁶ /°C	10kHz	< 0.25 mT	20 ~ 60°C	15	8	6	8	6	3
Curie Temperature	Tc	°C				220	180	160	160	130	100
Resistivity	ρ	Ωm				> 10 ⁶	> 10 ⁶	> 10 ⁶	> 10 ⁶	> 10 ⁶	> 10 ⁶
Density	d	g/cm ³				5.10	5.10	5.10	5.10	5.10	5.10

Note: Material characteristics are typical for a toroid core.

Product specification will differ from these data due to the influence of geometry and size.

Material Characteristics (14)

	Symbol	Unit	Measuring Conditions			Low Loss Materials	
			Freq.	Flux den.	Temp.	K081	K12
Initial Permeability	μ_i		$\leq 10\text{kHz}$	0.25mT	25°C	800 ± 25%	1200 ± 25%
Power Loss	Pv	KW/m ³	50kHz	150mT	25°C	400	315
					100°C	300	270
					120°C	295	287
Saturation Flux Density	Bms	mT	1kHz	H = 1200A/m	25°C	410	355
Remanence	Brms	mT	1kHz	H = 1200A/m	25°C	272	250
Coercivity	Hc	A/m	1kHz	H = 1200A/m	25°C	27	17
Curie Temperature	Tc	°C				190	160
Resistivity	ρ	Ωm				> 10 ⁶	> 10 ⁶
Density	d	g/cm ³				5.10	5.10

Note: Material characteristics are typical for a toroid core.

Product specification will differ from these data due to the influence of geometry and size.

Material Characteristics (15)

	Symbol	Unit	Measuring Conditions			High Bs Materials					
			Freq.	Flux den.	Temp.	B25	B30	B40	B45	B60	B90
Initial Permeability	μ_i		≤10kHz	0.25mT	25°C	250 ± 25%	300 ± 25%	400 ± 25%	450 ± 25%	600 ± 25%	900 ± 25%
Saturation Flux Density	Bms	mT	1kHz	H = 4000A/m	25°C	450	470	430	450	430	390
Remanence	Brms	mT	1kHz	H = 4000A/m	25°C	270	340	270	320	310	270
Coercivity	Hc	A/m	1kHz	H = 4000A/m	25°C	80	70	45	40	36	30
Relative Loss Factor	$\tan\delta/\mu_i$	10 ⁻⁶	100kHz	< 0.25mT	25°C	60	35	21	30	18	13
Temperature Factor of Permeability	α_F	10 ⁻⁶ /°C	10kHz	< 0.25 mT	20 ~ 60°C	12	16	10	15	12	8
Curie Temperature	Tc	°C				250	300	240	240	210	180
Resistivity	ρ	Ωm				> 10 ⁶	> 10 ⁶	> 10 ⁶	> 10 ⁶	> 10 ⁶	> 10 ⁶
Density	d	g/cm ³				5.20	5.20	5.20	5.20	5.20	5.20

Note: Material characteristics are typical for a toroid core.
Product specification will differ from these data due to the influence of geometry and size.

Material Characteristics (16)

	Symbol	Unit	Measuring Conditions			Rod Core Materials							
			Freq.	Flux den.	Temp.	H2	H3	H3A	H3B	H4	H5	H5M	H5R
Initial Permeability	μ_i		≤10kHz	0.25mT	25°C	50 ± 25%	100 ± 25%	125 ± 25%	150 ± 25%	300 ± 25%	250 ± 25%	230 ± 25%	200 ± 25%
Relative Loss Factor	$\tan\delta/\mu_i$	10 ⁻⁶	1kHz		25°C	285	88	390	163	145	50	50	50
Saturation Flux Density	Bms	mT	1kHz	H = 4000A/m	25°C	400	330	320	330	330	410	430	400
					100°C	350	275	262	270	240	345	366	330
Remanence	Brms	mT	1kHz	H = 4000A/m	25°C	281	234	219	247	222	324	272	320
					100°C	238	110	163	186	133	243	189	230
Coercivity	Hc	A/m	1kHz	H = 4000A/m	25°C	168	87	115	91	47	68	92	55
					100°C	121	64	83	62	30	32	79	32
Temperature Factor of Permeability	α_F	10 ⁻⁶ /°C			20 ~ 80°C	100	80	110	60	100	40	30	25
Curie Temperature	Tc	°C				300	250	230	220	160	250	280	240
Resistivity	ρ	Ωm				10 ⁶	10 ⁶	10 ⁶	10 ⁶	10 ⁶	10 ⁶	10 ⁶	10 ⁶
Density	d	g/cm ³				5.10	4.80	4.60	4.80	4.80	5.10	5.10	5.10

Note: Material characteristics are typical for a toroid core.
Product specification will differ from these data due to the influence of geometry and size.

Material Characteristics (17)

	Symbol	Unit	Measuring Conditions			Wide Temperature Antenna Materials	
			Freq.	Flux den.	Temp.	F50	F51
Initial Permeability	μ_i		$\leq 10\text{kHz}$	0.25mT	25°C	500 \pm 25%	500 \pm 25%
Saturation Flux Density	Bms	mT	1kHz	H = 4000A/m	25°C	332	338
Remanence	Brms	mT	1kHz	H = 4000A/m	25°C	127	118
Coercivity	Hc	A/m	1kHz	H = 4000A/m	25°C	51	49
Relative Loss Factor	$\tan\delta/\mu_i$	10 ⁻⁶	0.1MHz	< 0.25mT	25°C	21	20
Temperature Factor of Permeability	α_F	10 ⁻⁶ /°C			20 ~ 60°C	1	-1.3
Curie Temperature	Tc	°C				130	140
Resistivity	ρ	Ωm				> 10 ⁶	> 10 ⁶
Density	d	g/cm ³				5.10	5.10

Note: Material characteristics are typical for a toroid core.

Product specification will differ from these data due to the influence of geometry and size.

Material Characteristics (18)

	Symbol	Unit	Measuring Conditions			Low μ Materials					
			Freq.	Flux den.	Temp.	L1	L2	L3	L4	L5	L6
Initial Permeability	μ_i		$\leq 10\text{kHz}$	0.25mT	25°C	150 \pm 25%	60 \pm 25%	20 \pm 25%	50 \pm 25%	100 \pm 25%	14 \pm 25%
Saturation Flux Density	Bms	mT	1kHz	H = 4000A/m	25°C	410	421	306*	395	390	266*
Remanence	Brms	mT	1kHz	H = 4000A/m	25°C	168	274	122*	255	175	175*
Coercivity	Hc	A/m	1kHz	H = 4000A/m	25°C	105	141	600*	200	140	1540*
Relative Loss Factor	$\tan\delta/\mu_i$	10 ⁻⁶	10MHz	< 0.25mT	25°C	180**	150	448	169	350**	707
Curie Temperature	Tc	°C				250	250	300	300	250	300
Resistivity	ρ	Ωm				> 10 ⁶	> 10 ⁶	> 10 ⁶	> 10 ⁶	> 10 ⁶	> 10 ⁶
Density	d	g/cm ³				5.10	5.10	5.10	5.10	5.10	5.10

* Measuring Conditions H=8000A/m

** Measuring Conditions Freq.=10KHz

Note: Material characteristics are typical for a toroid core.

Product specification will differ from these data due to the influence of geometry and size.

	Symbol	Unit	Measuring Conditions			Low Loss Material
			Freq.	Flux den.	Temp.	P4
Initial Permeability	μ_i		$\leq 10\text{kHz}$	0.25mT	25°C	2500 \pm 25%
Amplitude Permeability	μ_a		25kHz	200mT	25°C	> 4500
					100°C	> 4500
Power Loss	Pv	KW/m ³	25kHz	200mT	25°C	105
					100°C	55
			100kHz	200mT	25°C	700
					100°C	450
			300kHz	100mT	25°C	660
					100°C	430
500kHz	50mT	25°C	380			
		100°C	330			
Saturation Flux Density	Bms	mT	10kHz	H = 1200A/m	25°C	480
Remanence	Brms	mT	10kHz	H = 1200A/m	25°C	100
					100°C	70
Coercivity	Hc	A/m	10kHz	H = 1200A/m	25°C	10
					100°C	6
Hysteresis Material Constant	η_B	10 ⁻⁶ /mT	10kHz	1.5-3.0mT	25°C	< 1.2
Disaccommodation Factor	D _F	10 ⁻⁶	10kHz	< 0.25 mT	25°C	< 2
Curie Temperature	T _c	°C				220
Resistivity	ρ	Ωm				5.50
Density	d	g/cm ³				4.80

Note: Material characteristics are typical for a toroid core.
Product specification will differ from these data due to the influence of geometry and size.

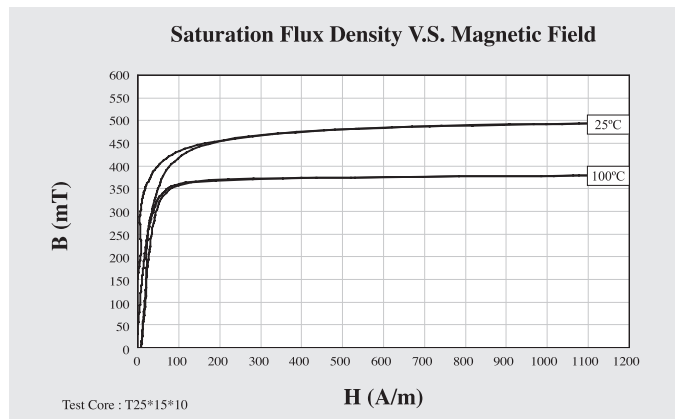
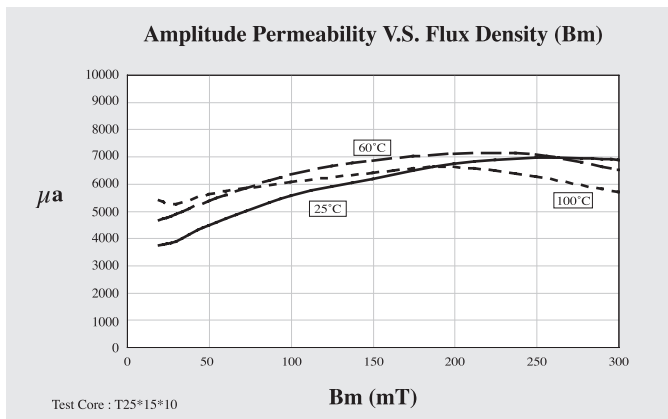
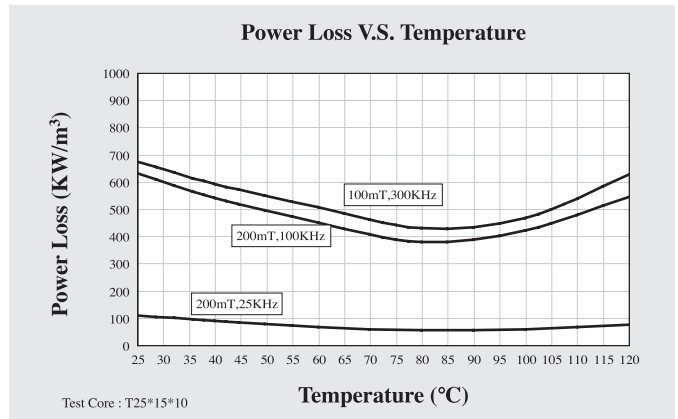
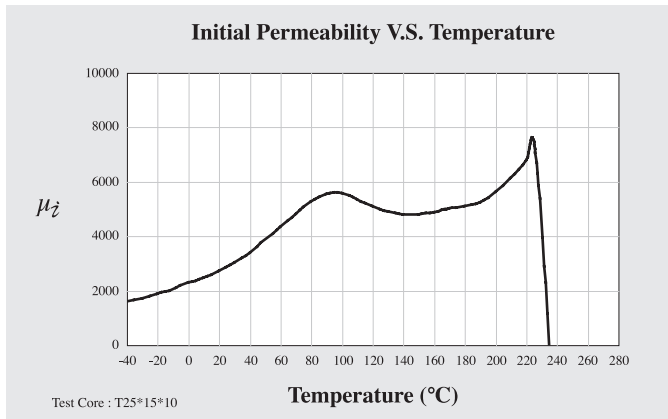
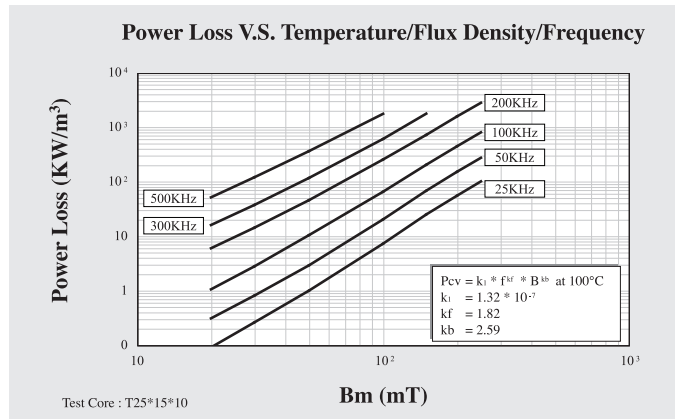
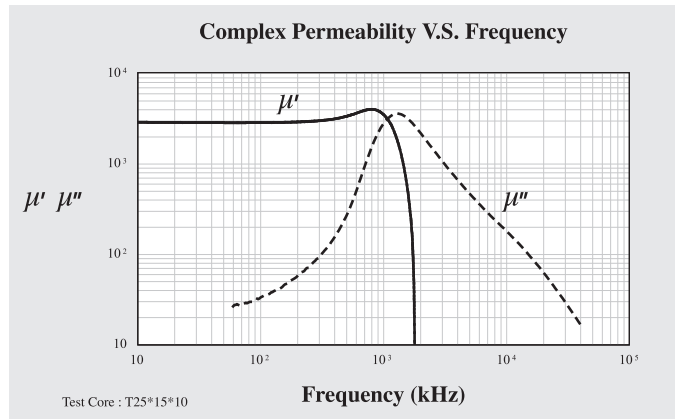

	Symbol	Unit	Measuring Conditions			Low Loss Material
			Freq.	Flux den.	Temp.	P41
Initial Permeability	μ_i		$\leq 10\text{kHz}$	0.25mT	25°C	2400 \pm 25%
Amplitude Permeability	μ_a		25kHz	200mT	25°C	> 4500
					100°C	> 4500
Power Loss	Pv	KW/m ³	25kHz	200mT	25°C	125
					100°C	50
			100kHz	200mT	25°C	650
					100°C	350
			300kHz	100mT	25°C	820
					100°C	500
500kHz	50mT	25°C	400			
Saturation Flux Density	Bms	mT	10kHz	H = 1200A/m	25°C	495
					100°C	395
Remanence	Brms	mT	10kHz	H = 1200A/m	25°C	170
					100°C	70
Coercivity	Hc	A/m	10kHz	H = 1200A/m	25°C	11
					100°C	6
Hysteresis Material Constant	η_B	10 ⁻⁶ /mT	10kHz	1.5-3.0mT	25°C	< 1
Disaccommodation Factor	D _F	10 ⁻⁶	10kHz	< 0.25 mT	25°C	< 2
Curie Temperature	T _c	°C				230
Resistivity	ρ	Ωm				4.00
Density	d	g/cm ³				4.85

Note: Material characteristics are typical for a toroid core.
Product specification will differ from these data due to the influence of geometry and size.

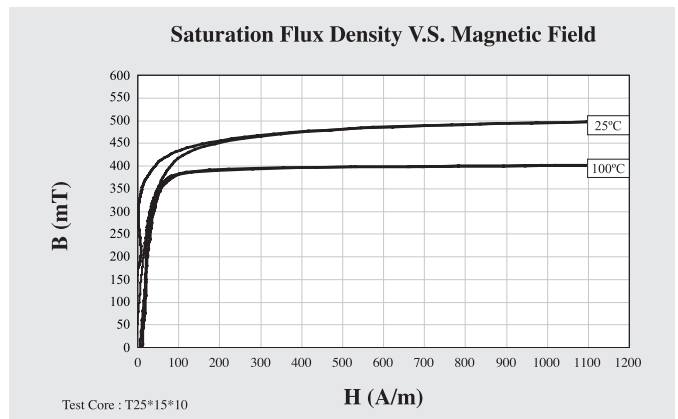
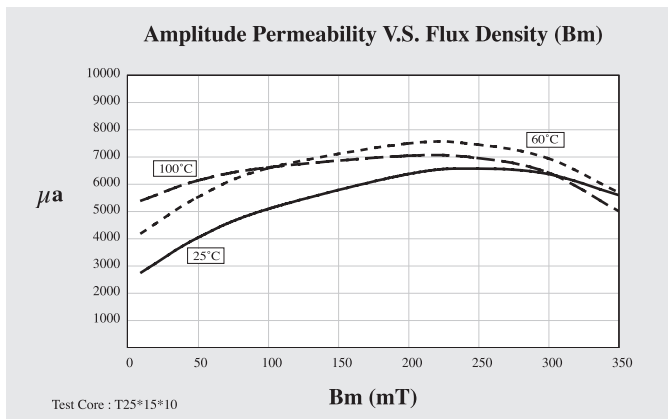
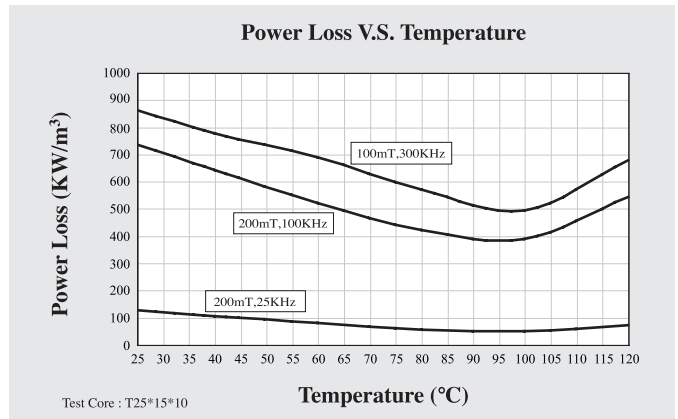
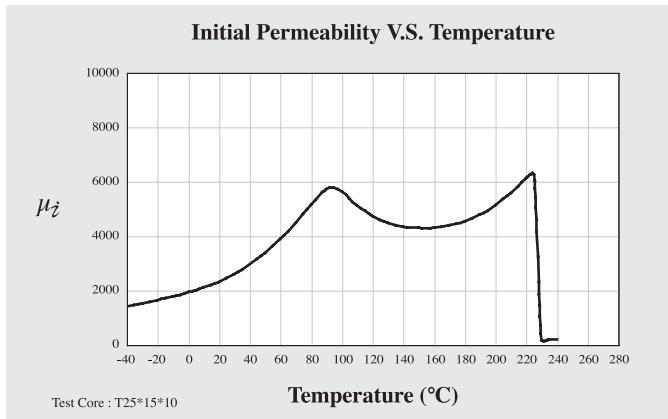
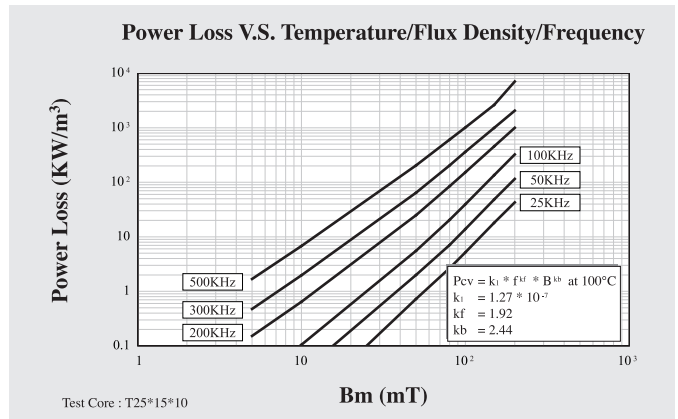
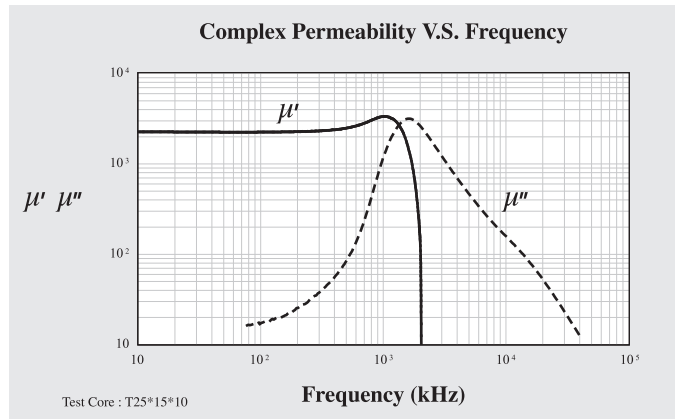

	Symbol	Unit	Measuring Conditions			Low Loss Material		
			Freq.	Flux den.	Temp.	P42		
Initial Permeability	μ_i		$\leq 10\text{kHz}$	0.25mT	25°C	1800 \pm 25%		
Amplitude Permeability	μ_a		25kHz	200mT	25°C	> 5000		
					100°C	> 5000		
Power Loss	Pv	KW/m ³	25kHz	200mT	25°C	125		
					100°C	50		
					100kHz	200mT	25°C	750
							100°C	350
					300kHz	100mT	25°C	900
							100°C	500
500kHz	50mT	25°C	450					
Saturation Flux Density	Bms	mT	10kHz	H = 1200A/m	25°C	520		
					100°C	420		
Remanence	Brms	mT	10kHz	H = 1200A/m	25°C	200		
					100°C	70		
Coercivity	Hc	A/m	10kHz	H = 1200A/m	25°C	12		
					100°C	6		
Hysteresis Material Constant	η_B	10 ⁻⁶ /mT	10kHz	1.5-3.0mT	25°C	< 1		
Disaccommodation Factor	D ^F	10 ⁻⁶	10kHz	< 0.25 mT	25°C	< 2		
Curie Temperature	Tc	°C				240		
Resistivity	ρ	Ωm				8.00		
Density	d	g/cm ³				4.90		

Note: Material characteristics are typical for a toroid core.
Product specification will differ from these data due to the influence of geometry and size.

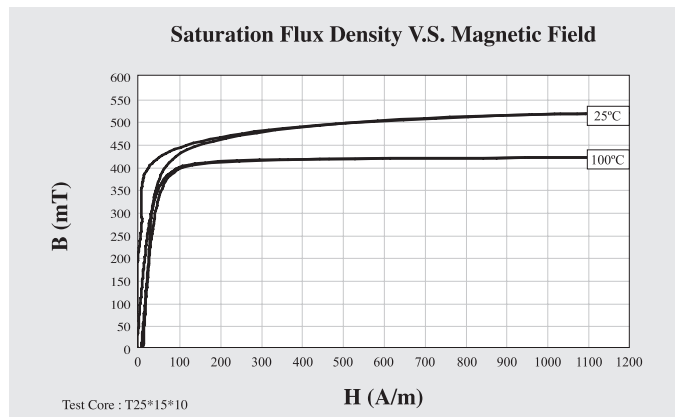
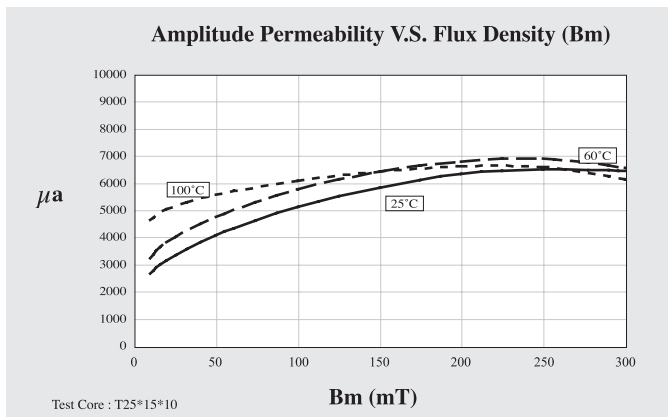
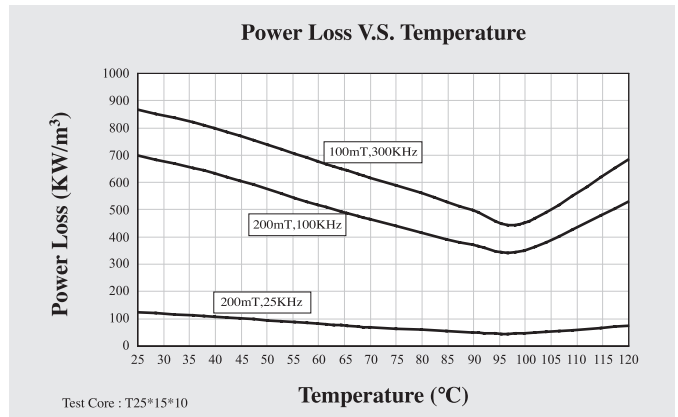
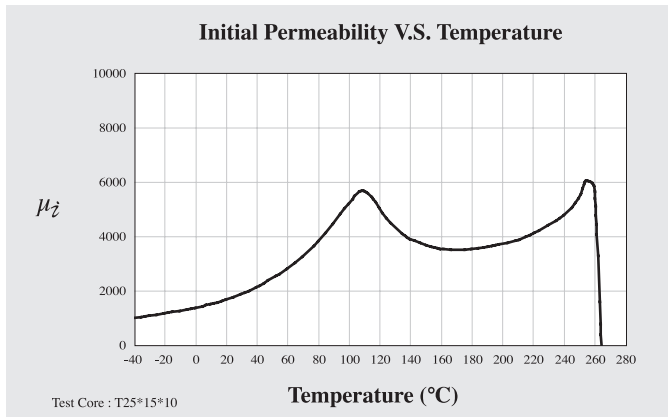
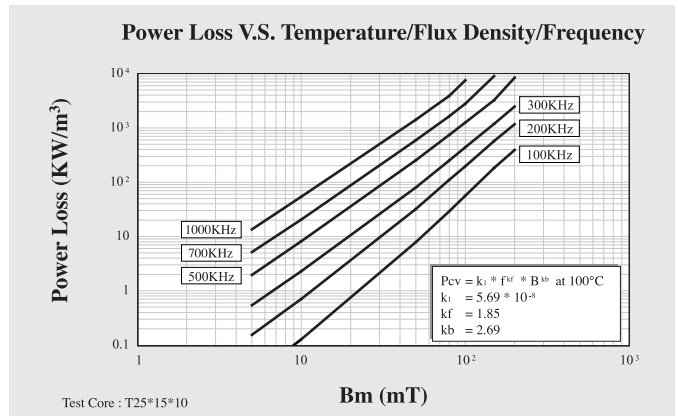
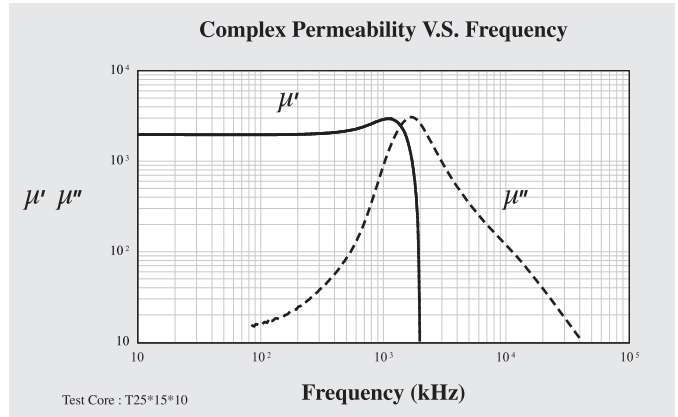

	Symbol	Unit	Measuring Conditions			Low Loss Material		
			Freq.	Flux den.	Temp.	P48		
Initial Permeability	μ_i		$\leq 10\text{kHz}$	0.25mT	25°C	2500 \pm 25%		
Amplitude Permeability	μ_a		25kHz	200mT	25°C	> 5000		
					100°C	> 5000		
Power Loss	Pv	KW/m ³	25kHz	200mT	25°C			
					100°C			
					100kHz	200mT	25°C	550
							100°C	250
					300kHz	100mT	25°C	500
		100°C	300					
			500kHz	50mT	25°C	250		
					100°C	200		
Saturation Flux Density	Bms	mT	10kHz	H = 1200A/m	25°C	515		
					100°C	410		
Remanence	Brms	mT	10kHz	H = 1200A/m	25°C	150		
					100°C	60		
Coercivity	Hc	A/m	10kHz	H = 1200A/m	25°C	13		
					100°C	7		
Hysteresis Material Constant	η_B	10 ⁻⁶ /mT	10kHz	1.5-3.0mT	25°C	< 1		
Disaccommodation Factor	D _f	10 ⁻⁶	10kHz	< 0.25 mT	25°C	< 2		
Curie Temperature	T _c	°C				220		
Resistivity	ρ	Ωm				5.00		
Density	d	g/cm ³				4.90		

Note: Material characteristics are typical for a toroid core.
Product specification will differ from these data due to the influence of geometry and size.

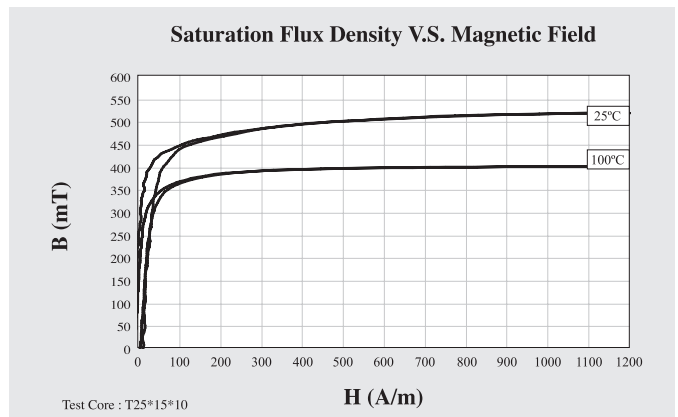
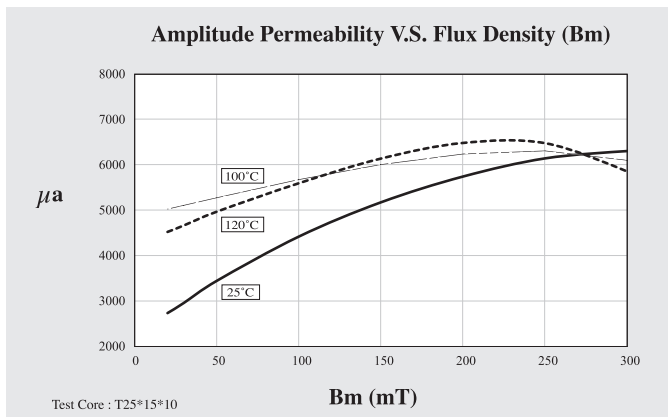
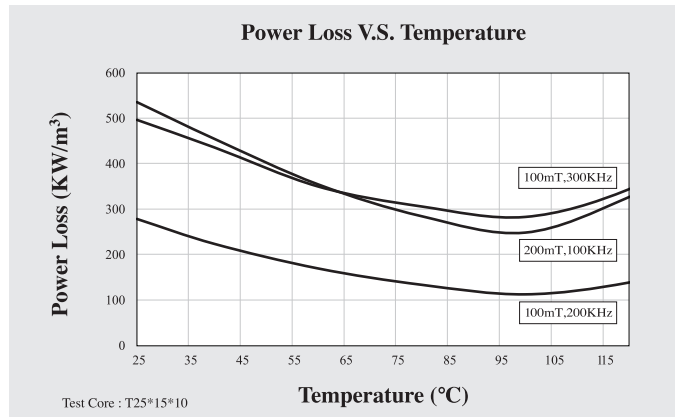
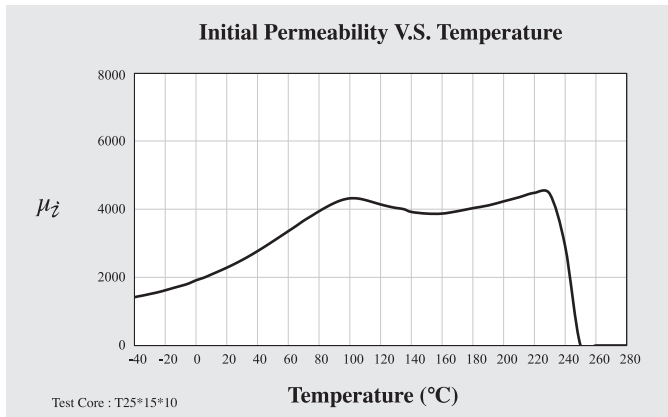
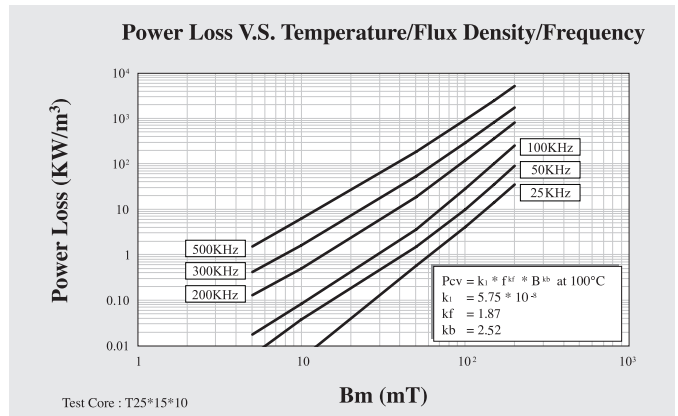
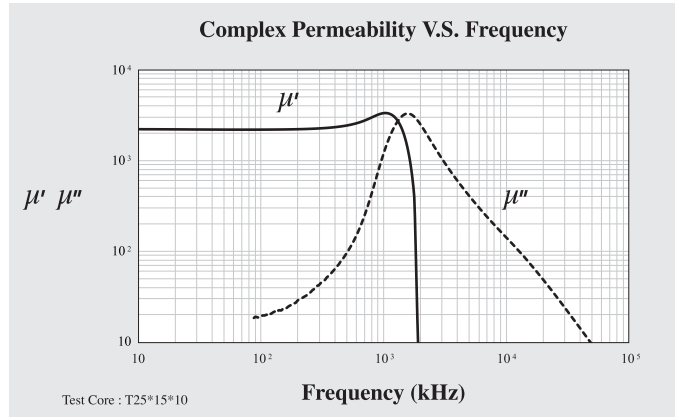

	Symbol	Unit	Measuring Conditions			Wide Temperature Low Loss Material		
			Freq.	Flux den.	Temp.	P45		
Initial Permeability	μ_i		$\leq 10\text{kHz}$	0.25mT	25°C	3100 \pm 25%		
Amplitude Permeability	μ_a		25kHz	200mT	25°C	> 5000		
					100°C	> 5000		
Power Loss	Pv	KW/m ³	25kHz	200mT	25°C			
					100°C			
					100kHz	200mT	25°C	360
							100°C	260
					300kHz	100mT	25°C	350
							100°C	300
		500kHz	50mT	25°C	200			
				100°C	200			
Saturation Flux Density	Bms	mT	10kHz	H = 1200A/m	25°C	530		
					100°C	405		
Remanence	Brms	mT	10kHz	H = 1200A/m	25°C	80		
					100°C	60		
Coercivity	Hc	A/m	10kHz	H = 1200A/m	25°C	9.5		
					100°C	6		
Hysteresis Material Constant	η_B	10 ⁻⁶ /mT	10kHz	1.5-3.0mT	25°C	< 0.6		
Disaccommodation Factor	D _f	10 ⁻⁶	10kHz	< 0.25 mT	25°C	< 1		
Curie Temperature	T _c	°C				215		
Resistivity	ρ	Ωm				5.00		
Density	d	g/cm ³				4.90		

Note: Material characteristics are typical for a toroid core.
Product specification will differ from these data due to the influence of geometry and size.

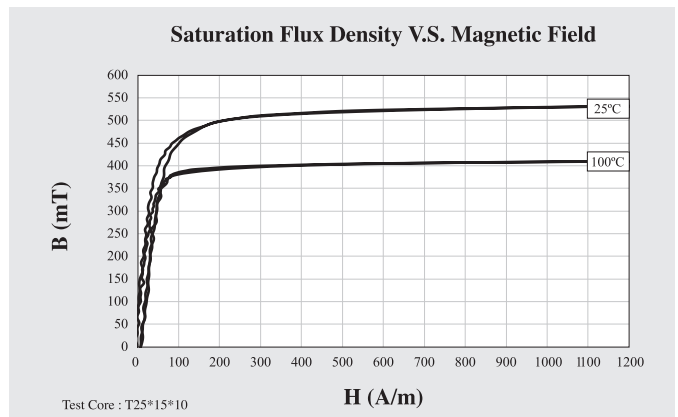
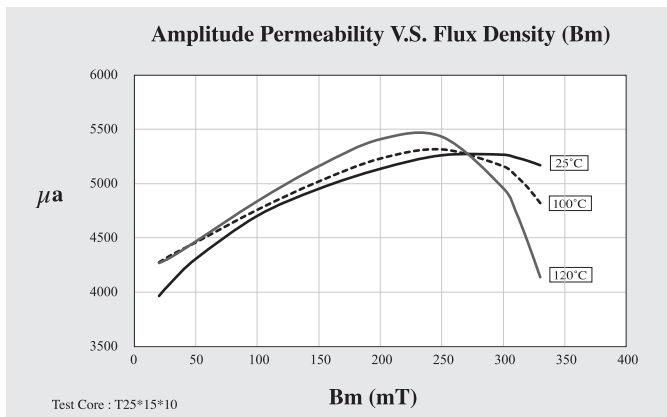
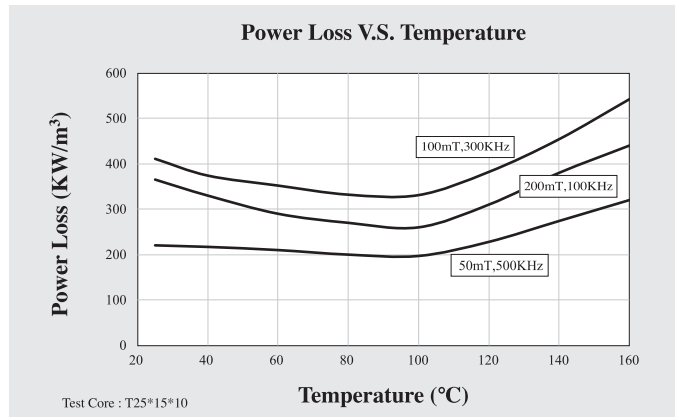
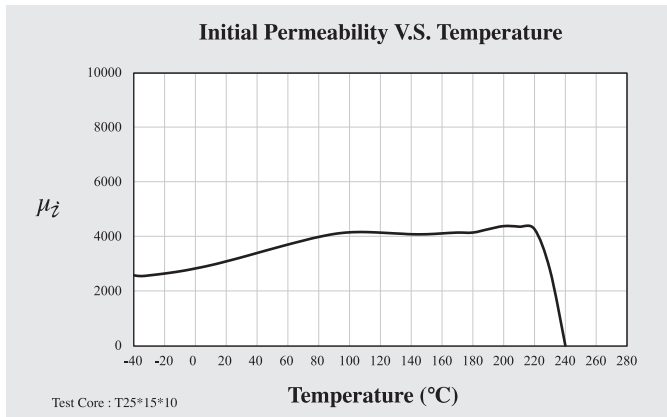
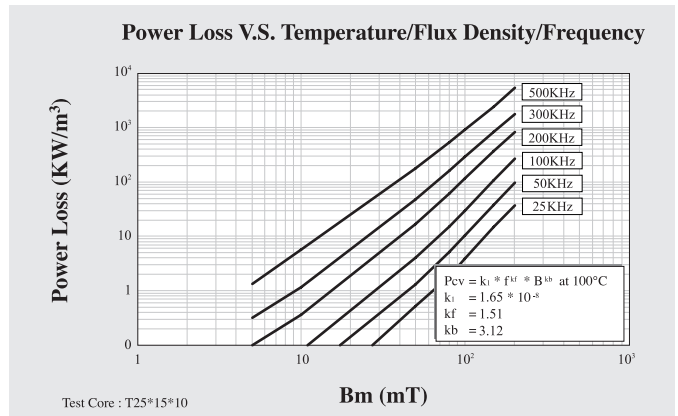
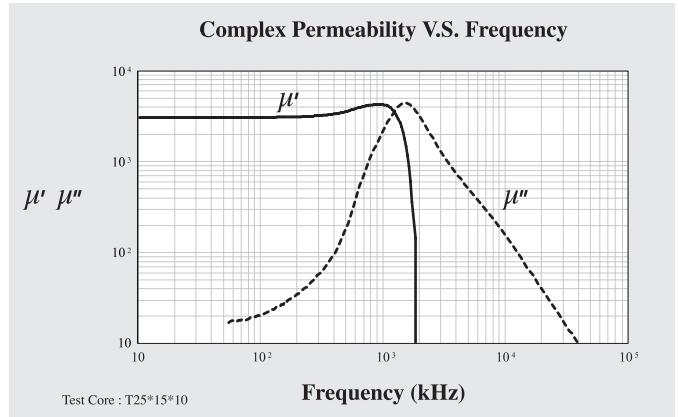

	Symbol	Unit	Measuring Conditions			Wide Temperature Low Loss Material
			Freq.	Flux den.	Temp.	P46
Initial Permeability	μ_i		$\leq 10\text{kHz}$	0.25mT	25°C	3300 \pm 25%
Amplitude Permeability	μ_a		25kHz	200mT	25°C	> 4500
					100°C	> 4500
Power Loss	Pv	KW/m ³	25kHz	200mT	25°C	60
					100°C	60
			100kHz	200mT	25°C	400
					100°C	400
			300kHz	100mT	25°C	400
					100°C	400
500kHz	50mT	25°C	230			
			100°C	230		
Saturation Flux Density	Bms	mT	10kHz	H = 1200A/m	25°C	480
					100°C	370
Remanence	Brms	mT	10kHz	H = 1200A/m	25°C	100
					100°C	70
Coercivity	Hc	A/m	10kHz	H = 1200A/m	25°C	10
					100°C	6
Hysteresis Material Constant	η_B	10 ⁻⁶ /mT	10kHz	1.5-3.0mT	25°C	< 1.2
Disaccommodation Factor	D _F	10 ⁻⁶	10kHz	< 0.25 mT	25°C	< 2
Curie Temperature	T _c	°C				200
Resistivity	ρ	Ωm				5.00
Density	d	g/cm ³				4.80

Note: Material characteristics are typical for a toroid core.
Product specification will differ from these data due to the influence of geometry and size.

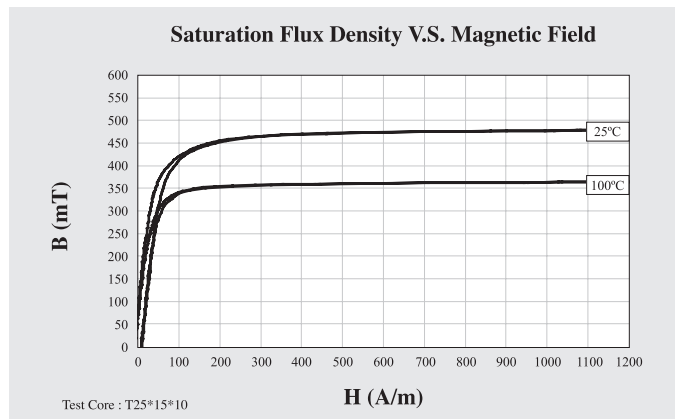
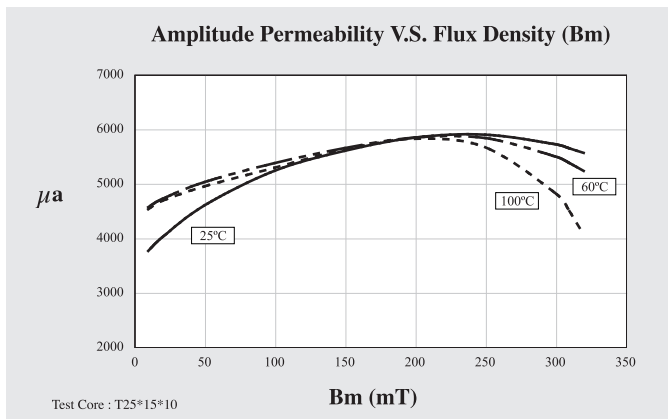
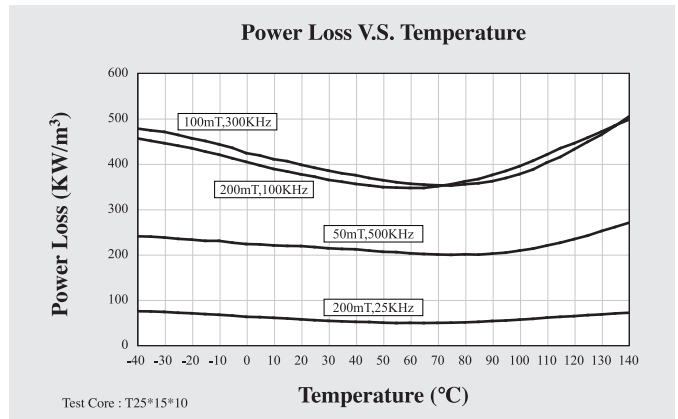
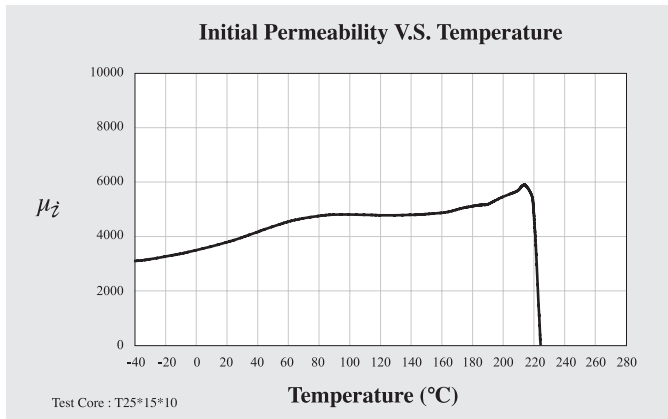
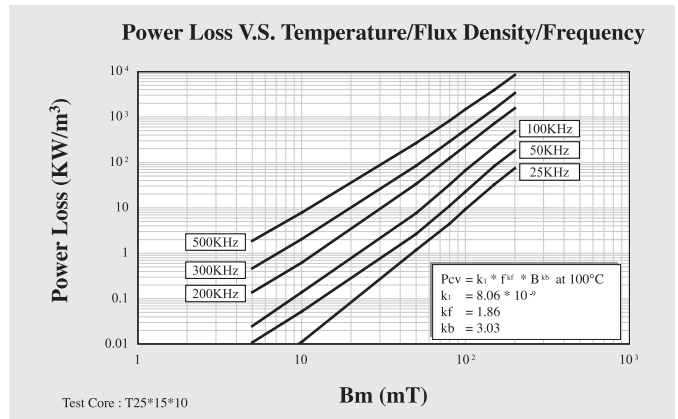
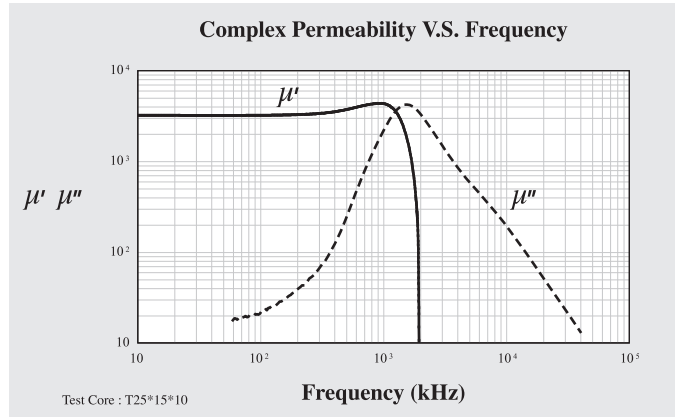

	Symbol	Unit	Measuring Conditions			Wide Temperature Low Loss Material		
			Freq.	Flux den.	Temp.	P47		
Initial Permeability	μ_i		$\leq 10\text{kHz}$	0.25mT	25°C	3000 \pm 25%		
Amplitude Permeability	μ_a		25kHz	200mT	25°C	> 5000		
					100°C	> 5000		
Power Loss	Pv	KW/m ³	25kHz	200mT	25°C			
					100°C			
					100kHz	200mT	25°C	400
							100°C	350
						300kHz	100mT	25°C
			100°C	350				
			500kHz	50mT	25°C	230		
					100°C	230		
Saturation Flux Density	Bms	mT	10kHz	H = 1200A/m	25°C	520		
					100°C	420		
Remanence	Brms	mT	10kHz	H = 1200A/m	25°C	85		
					100°C	70		
Coercivity	Hc	A/m	10kHz	H = 1200A/m	25°C	10		
					100°C	7		
Hysteresis Material Constant	η_B	10 ⁻⁶ /mT	10kHz	1.5-3.0mT	25°C	< 0.6		
Disaccommodation Factor	D _F	10 ⁻⁶	10kHz	< 0.25 mT	25°C	< 1		
Curie Temperature	T _c	°C				220		
Resistivity	ρ	Ωm				5.00		
Density	d	g/cm ³				4.90		

Note: Material characteristics are typical for a toroid core.
Product specification will differ from these data due to the influence of geometry and size.

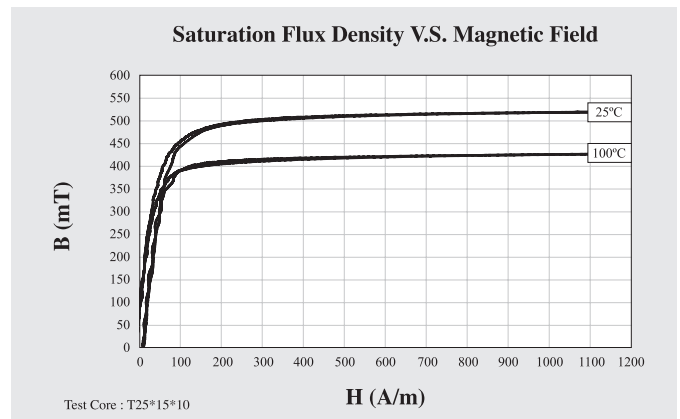
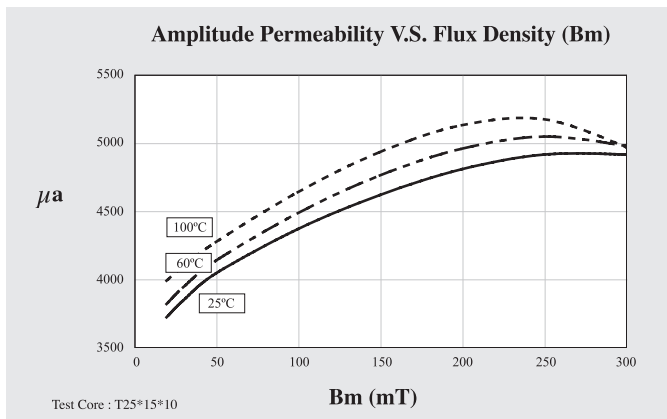
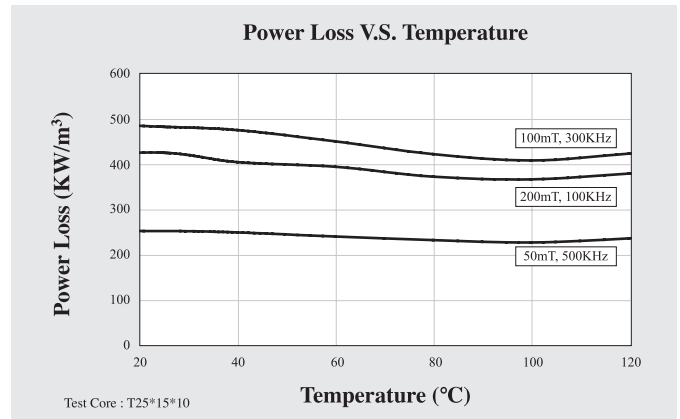
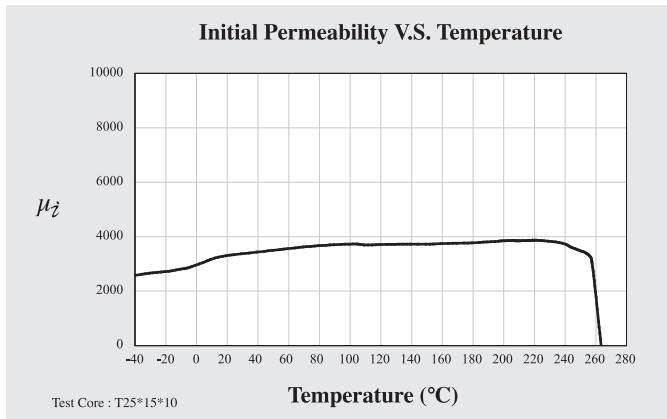
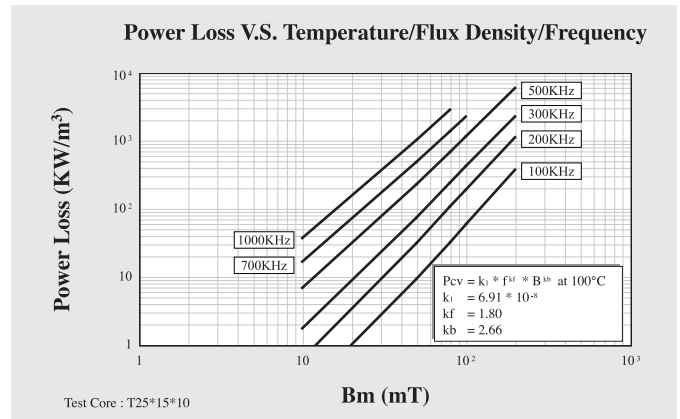
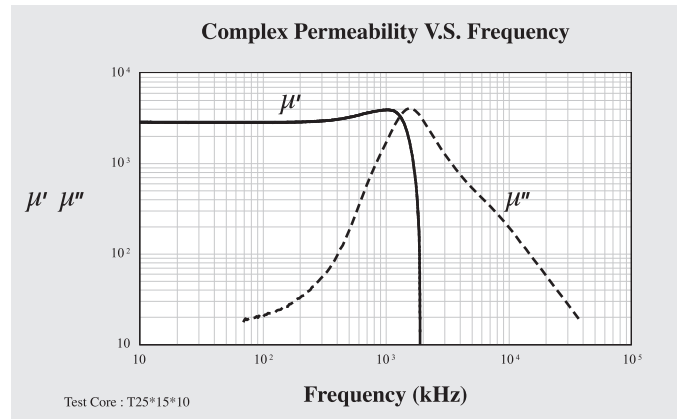

	Symbol	Unit	Measuring Conditions			Low Loss and High Bs Material P49
			Freq.	Flux den.	Temp.	
Initial Permeability	μ^i		$\leq 10\text{kHz}$	0.25mT	25°C	1700 \pm 25%
Power Loss	Pv	KW/m ³	100kHz	200mT	25°C	800
					100°C	400
			500kHz	50mT	25°C	450
					100°C	220
Saturation Flux Density	Bms	mT	10kHz	H = 1200A/m	25°C	540
					100°C	460
Remanence	Brms	mT	10kHz	H = 1200A/m	25°C	280
					100°C	60
Coercivity	Hc	A/m	10kHz	H = 1200A/m	25°C	13
					100°C	7
Curie Temperature	Tc	°C	10kHz	<0.25mT		>280
Resistivity	ρ	Ωm				5.00
Density	d	g/cm ³				4.90

Note: Material characteristics are typical for a toroid core.
Product specification will differ from these data due to the influence of geometry and size.

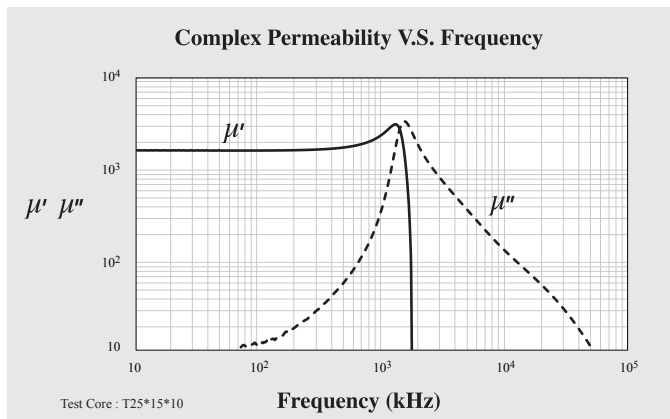
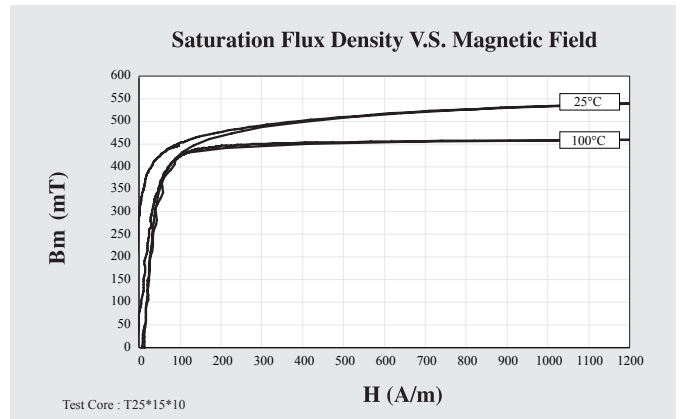
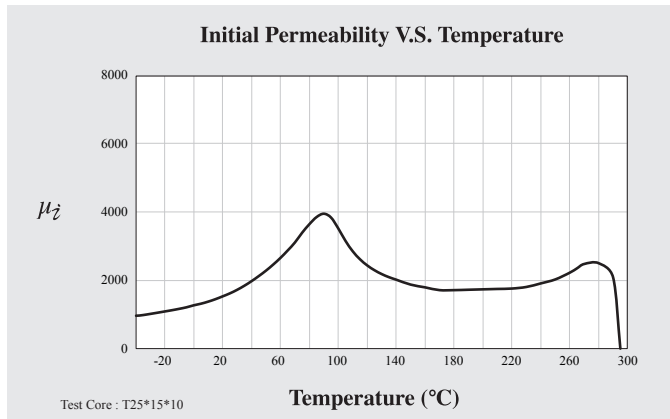
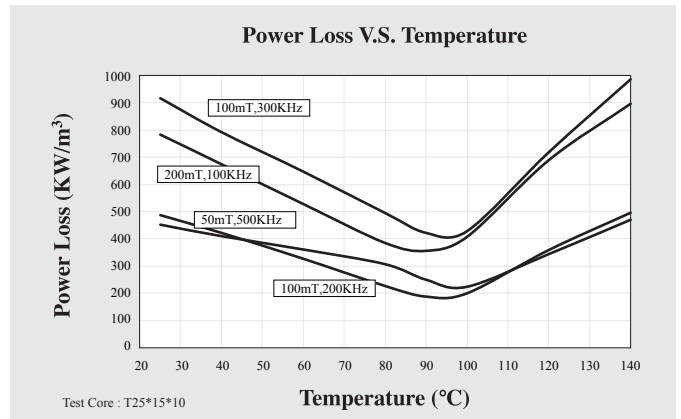
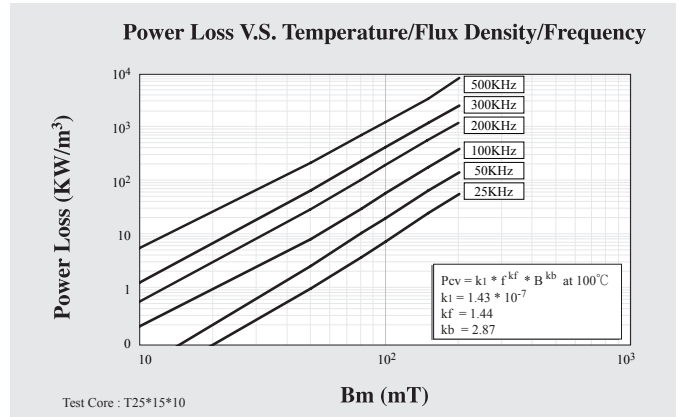

	Symbol	Unit	Measuring Conditions			Low Loss Material
			Freq.	Flux den.	Temp.	P5
Initial Permeability	μ_i		$\leq 10\text{kHz}$	0.25mT	25°C	2000 \pm 25%
Amplitude Permeability	μ_a		25kHz	200mT	25°C	> 4000
					100°C	> 4000
Power Loss	Pv	KW/m ³	300kHz	100mT	25°C	600
					100°C	450
			500kHz	50mT	25°C	220
					100°C	250
			700kHz	50mT	25°C	600
					100°C	550
1000kHz	50mT	25°C				
			100°C			
Saturation Flux Density	Bms	mT	10kHz	H = 1200A/m	25°C	470
Remanence	Brms	mT	10kHz	H = 1200A/m	25°C	100
					100°C	60
Coercivity	Hc	A/m	10kHz	H = 1200A/m	25°C	12
					100°C	8
Hysteresis Material Constant	η_B	10 ⁻⁶ /mT	10kHz	1.5-3.0mT	25°C	< 1
Disaccommodation Factor	D _F	10 ⁻⁶	10kHz	< 0.25 mT	25°C	< 2
Curie Temperature	T _c	°C				220
Resistivity	ρ	Ωm				6.40
Density	d	g/cm ³				4.70

Note: Material characteristics are typical for a toroid core.
Product specification will differ from these data due to the influence of geometry and size.

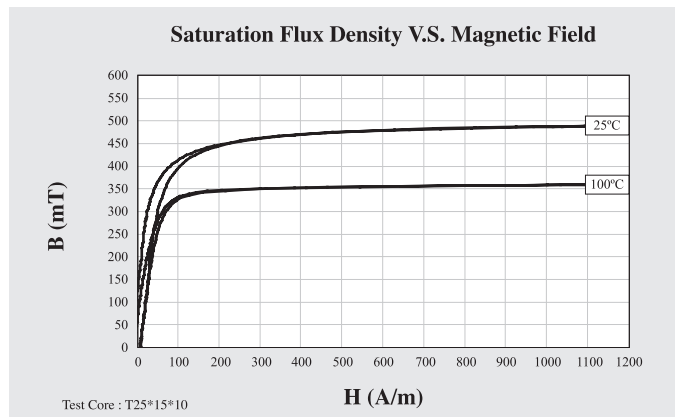
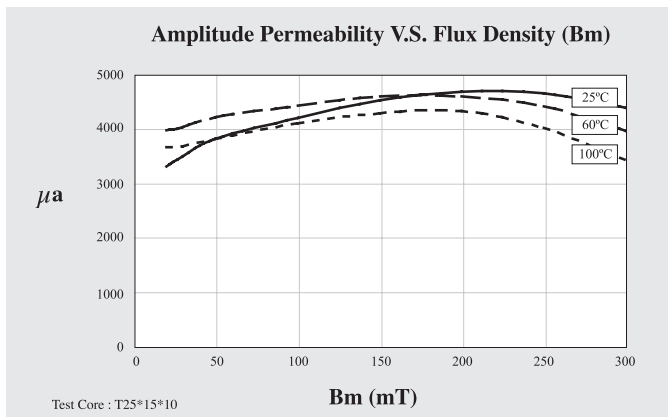
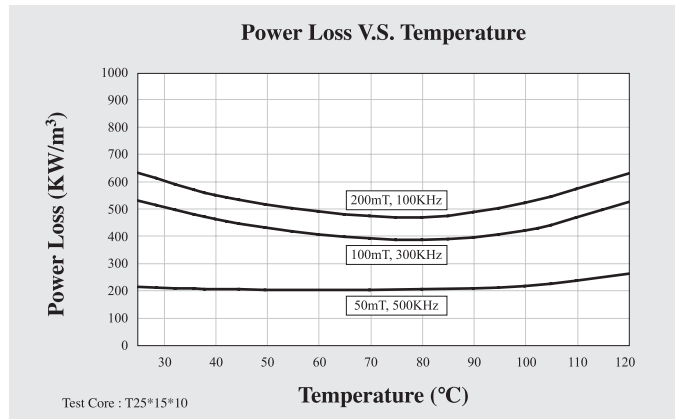
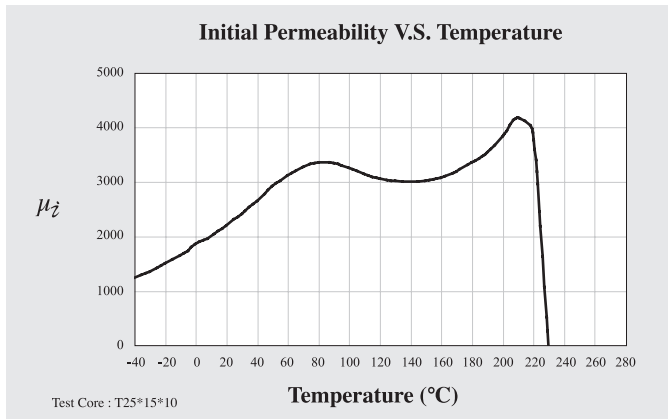
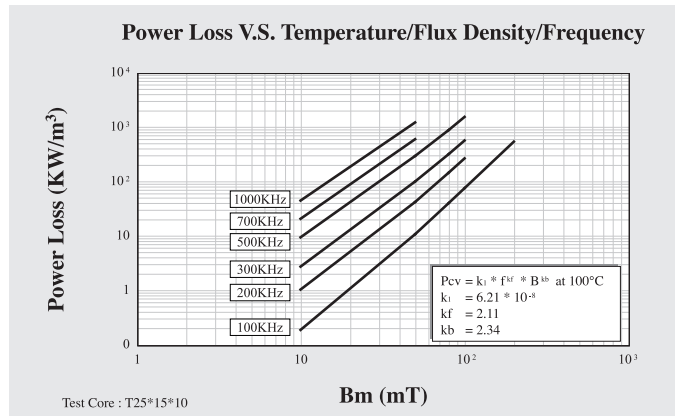
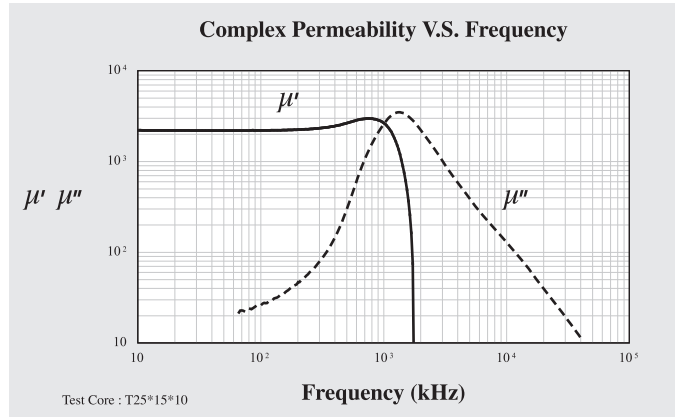

	Symbol	Unit	Measuring Conditions			Low Loss Material
			Freq.	Flux den.	Temp.	P51
Initial Permeability	μ_i		$\leq 10\text{kHz}$	0.25mT	25°C	1500 \pm 25%
Amplitude Permeability	μ_a		25kHz	200mT	25°C	> 2500
					100°C	> 2500
Power Loss	Pv	KW/m ³	300kHz	100mT	25°C	410
					100°C	310
			500kHz	50mT	25°C	200
					100°C	100
			700kHz	50mT	25°C	300
					100°C	250
1000kHz	50mT	25°C	600			
		100°C	600			
Saturation Flux Density	Bms	mT	10kHz	H = 1200A/m	25°C	490
					100°C	400
Remanence	Brms	mT	10kHz	H = 1200A/m	25°C	180
					100°C	130
Coercivity	Hc	A/m	10kHz	H = 1200A/m	25°C	30
					100°C	25
Hysteresis Material Constant	η_B	10 ⁻⁶ /mT	10kHz	1.5-3.0mT	25°C	< 1
Disaccommodation Factor	D _f	10 ⁻⁶	10kHz	< 0.25 mT	25°C	< 2
Curie Temperature	T _c	°C				250
Resistivity	ρ	Ωm				12.00
Density	d	g/cm ³				4.85

Note: Material characteristics are typical for a toroid core.
Product specification will differ from these data due to the influence of geometry and size.

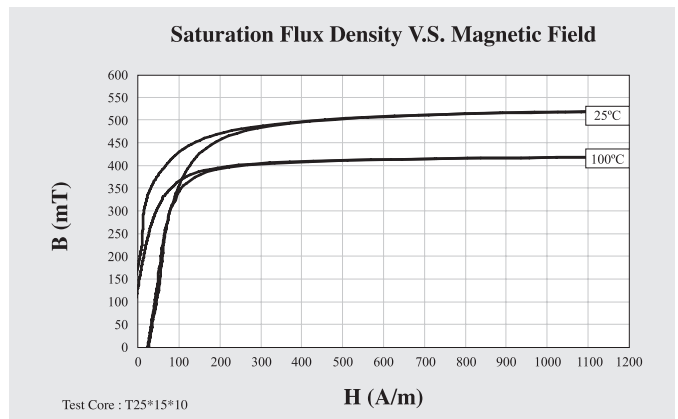
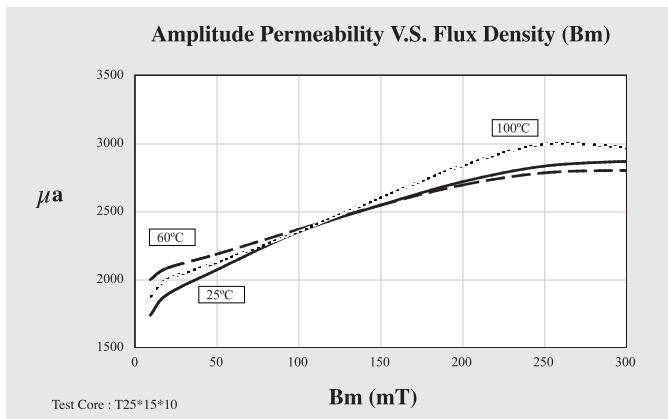
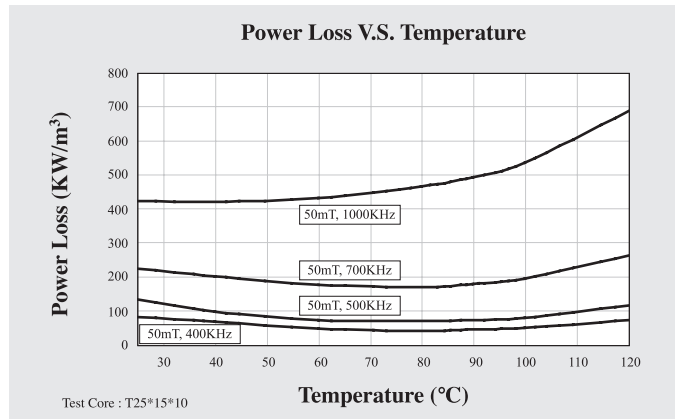
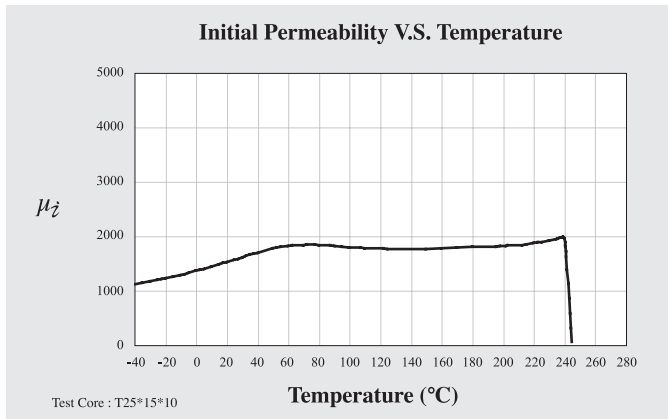
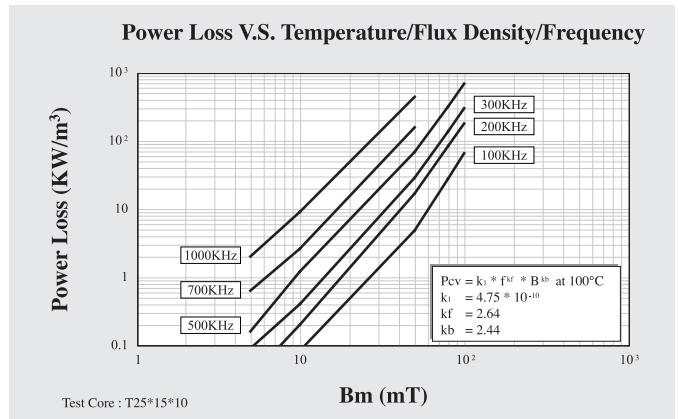
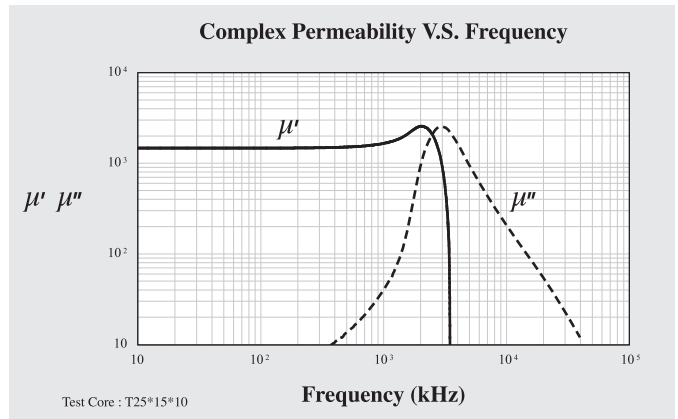

	Symbol	Unit	Measuring Conditions			Low Loss Material
			Freq.	Flux den.	Temp.	P52
Initial Permeability	μ_i		$\leq 10\text{kHz}$	0.25mT	25°C	2000 \pm 25%
Amplitude Permeability	μ_a		25kHz	200mT	25°C	> 4000
					100°C	> 4000
Power Loss	Pv	KW/m ³	300kHz	100mT	25°C	510
					100°C	450
			500kHz	50mT	25°C	210
					100°C	140
			700kHz	50mT	25°C	410
					100°C	400
1000kHz	50mT	25°C	1000			
		100°C	1000			
Saturation Flux Density	Bms	mT	10kHz	H = 1200A/m	25°C	500
					100°C	400
Remanence	Brms	mT	10kHz	H = 1200A/m	25°C	190
					100°C	100
Coercivity	Hc	A/m	10kHz	H = 1200A/m	25°C	21
					100°C	18
Hysteresis Material Constant	η_B	10 ⁻⁶ /mT	10kHz	1.5-3.0mT	25°C	< 1
Disaccommodation Factor	D _F	10 ⁻⁶	10kHz	< 0.25 mT	25°C	< 2
Curie Temperature	T _c	°C				250
Resistivity	ρ	Ωm				6.50
Density	d	g/cm ³				4.85

Note: Material characteristics are typical for a toroid core.
Product specification will differ from these data due to the influence of geometry and size.

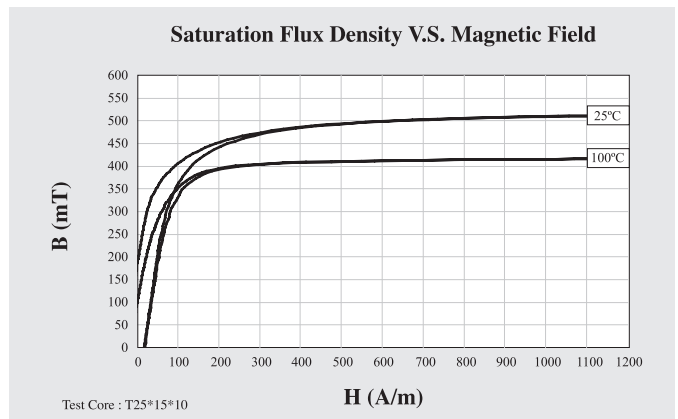
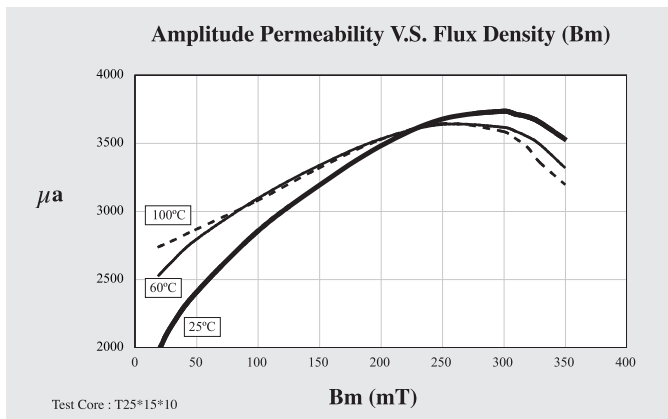
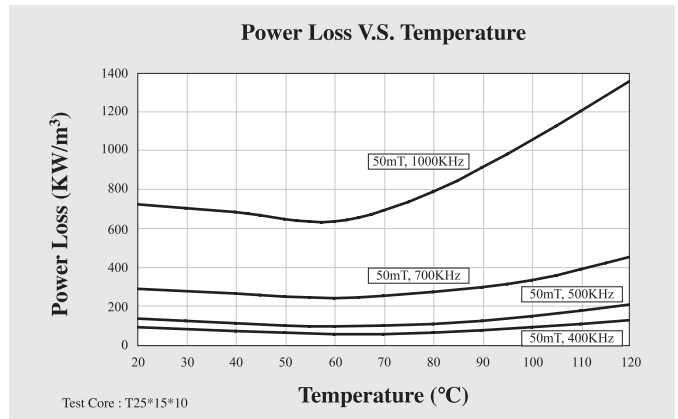
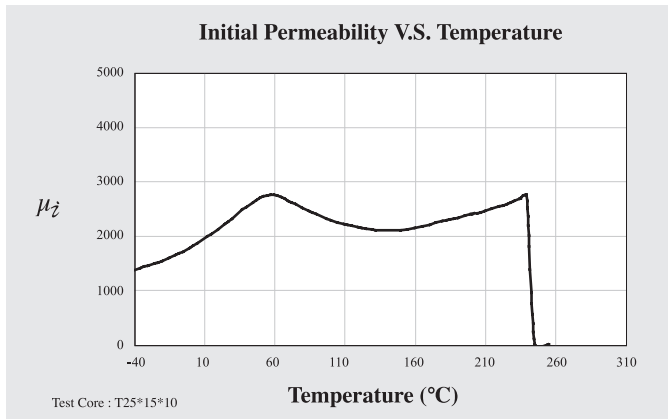
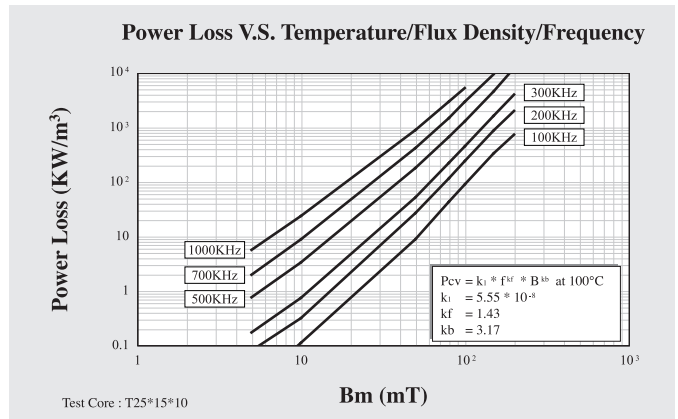
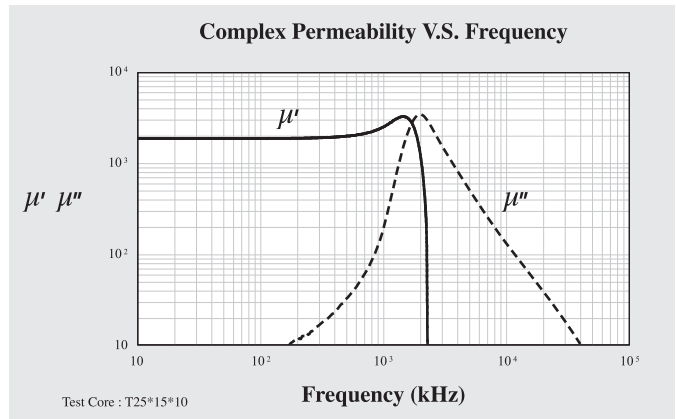

	Symbol	Unit	Measuring Conditions			High Frequency Low Loss Material
			Freq.	Flux den.	Temp.	P6
Initial Permeability	μ_i		$\leq 10\text{kHz}$	0.25mT	25°C	900 \pm 25%
Amplitude Permeability	μ_a		25kHz	200mT	25°C	1700
					100°C	1800
Power Loss	Pv	KW/m ³	1MHz	50mT	25°C	250
					100°C	150
			3MHz	10mT	25°C	50
					100°C	50
			3MHz	30mT	25°C	600
					100°C	500
5MHz	9mT	25°C	150			
			100°C	170		
Saturation Flux Density	Bms	mT	10kHz	H = 1200A/m	25°C	515
					100°C	430
Remanence	Brms	mT	10kHz	H = 1200A/m	25°C	250
					100°C	160
Coercivity	Hc	A/m	10kHz	H = 1200A/m	25°C	55
					100°C	45
Hysteresis Material Constant	ηB	10 ⁻⁶ /mT	10kHz	1.5-3.0mT	25°C	< 1
Disaccommodation Factor	Df	10 ⁻⁶	10kHz	< 0.25 mT	25°C	< 2
Curie Temperature	Tc	°C				280
Resistivity	ρ	Ωm				10.00
Density	d	g/cm ³				4.80

Note: Material characteristics are typical for a toroid core.
Product specification will differ from these data due to the influence of geometry and size.

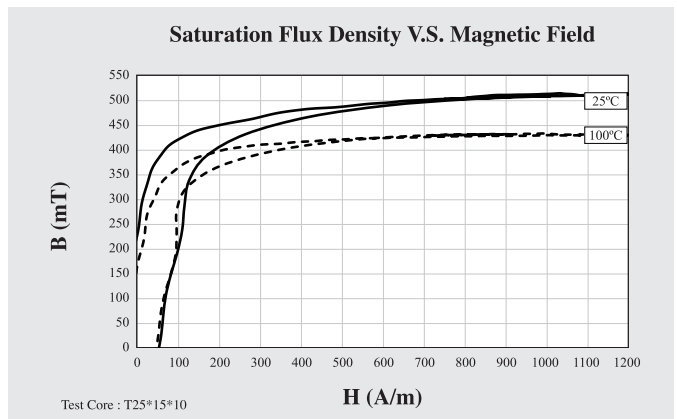
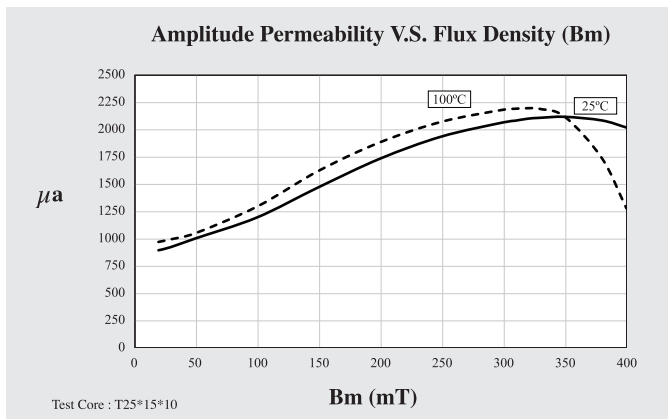
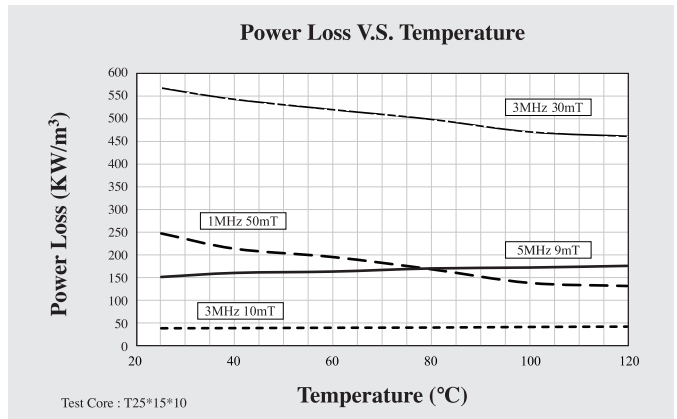
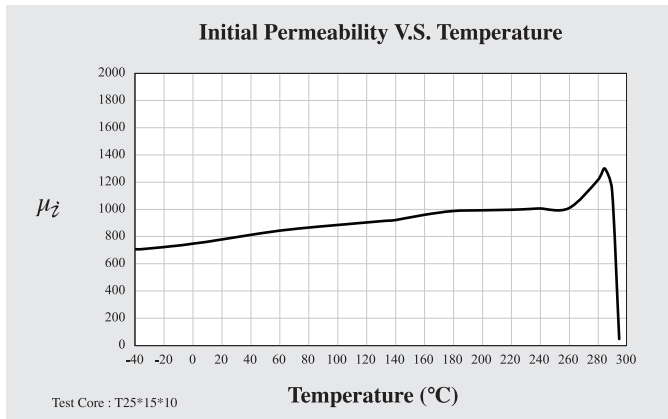
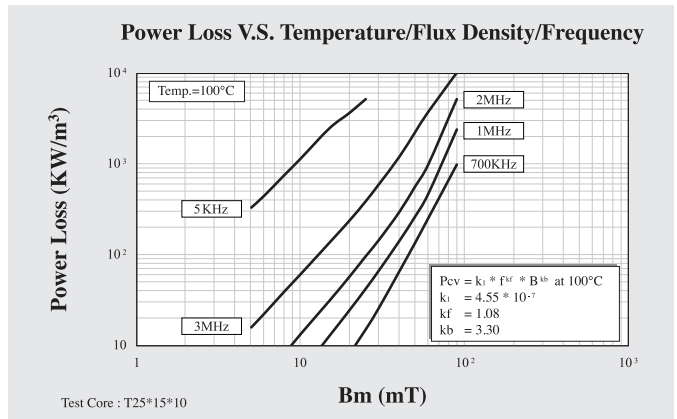
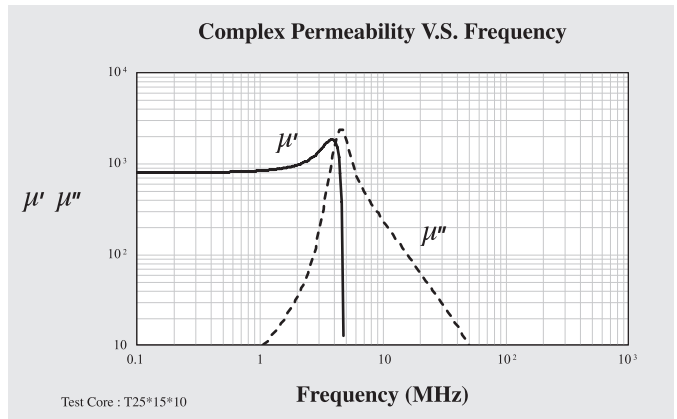

	Symbol	Unit	Measuring Conditions			High Permeability Material
			Freq.	Flux den.	Temp.	A05
Initial Permeability	μ_z		$\leq 10\text{kHz}$	0.25mT	25°C	5000 \pm 25%
Relative Loss Factor	$\tan\delta/\mu_z$	10^{-6}	10kHz	$< 0.25\text{mT}$	25°C	< 4
			100kHz		25°C	< 15
Saturation Flux Density	Bms	mT	10kHz	H = 1200A/m	25°C	440
					100°C	300
Remanence	Brms	mT	10kHz	H = 1200A/m	25°C	80
					100°C	90
Temperature Factor of Permeability	α_F	$10^{-6}/^\circ\text{C}$	10kHz	$< 0.25\text{ mT}$	0 ~ 20°C	0 ~ 2
					20 ~ 70°C	0 ~ 2
Hysteresis Material Constant	η_B	$10^{-6}/\text{mT}$	10kHz	1.5-3.0mT	25°C	< 0.8
Disaccommodation Factor	D _F	10^{-6}	10kHz	$< 0.25\text{ mT}$	25°C	< 3
Curie Temperature	T _c	°C				140
Resistivity	ρ	Ωm				0.20
Density	d	g/cm^3				4.85

Note: Material characteristics are typical for a toroid core.
 Product specification will differ from these data due to the influence of geometry and size.

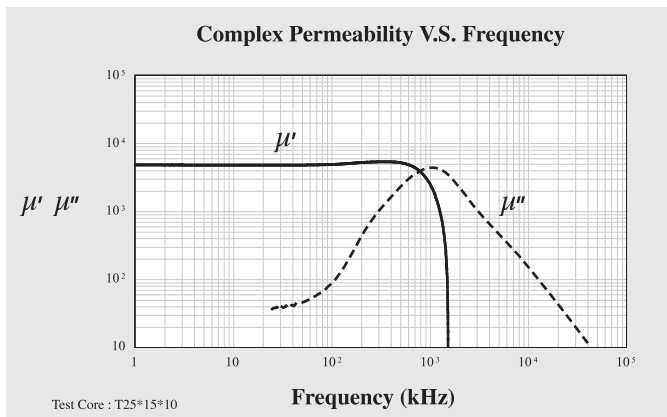
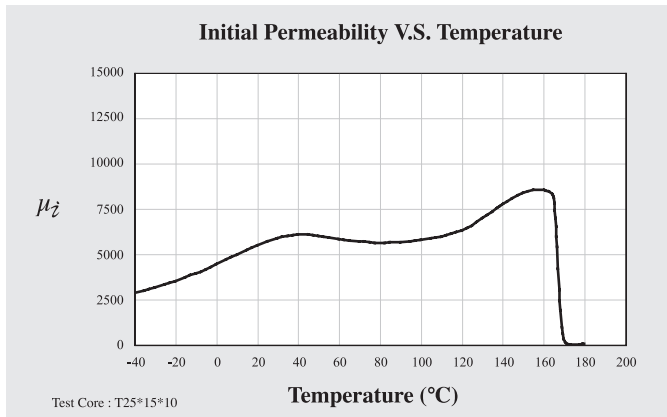
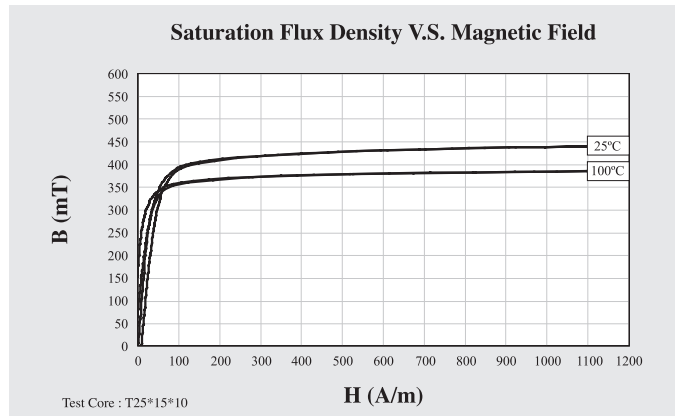
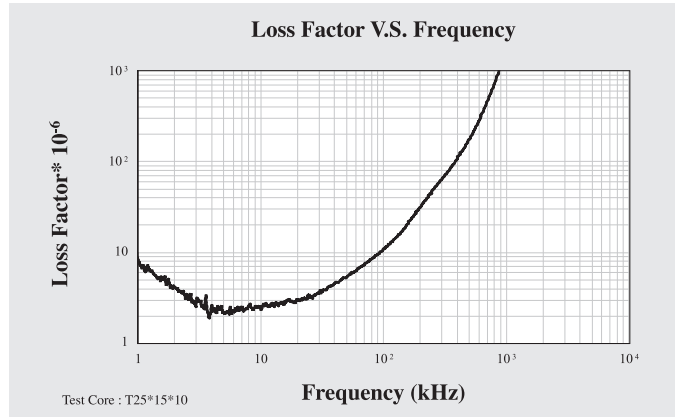

	Symbol	Unit	Measuring Conditions			Telecom High Permeability Material
			Freq.	Flux den.	Temp.	A062
Initial Permeability	μ_i		$\leq 10\text{kHz}$	0.25mT	25°C	6000 \pm 25%
Relative Loss Factor	$\tan\delta/\mu_i$	10 ⁻⁶	10kHz	< 0.25mT	25°C	< 10
			100kHz		25°C	< 30
Saturation Flux Density	B _{ms}	mT	10kHz	H = 1200A/m	25°C	460
					100°C	320
Remanence	B _{rms}	mT	10kHz	H = 1200A/m	25°C	100
					100°C	80
Temperature Factor of Permeability	α_F	10 ⁻⁶ /°C	10kHz	< 0.25 mT	0 ~ 20°C	1 ~ 3
					20 ~ 70°C	-1 ~ 1
Hysteresis Material Constant	η_B	10 ⁻⁶ /mT	10kHz	1.5-3.0mT	25°C	< 0.5
Disaccommodation Factor	D _F	10 ⁻⁶	10kHz	< 0.25 mT	25°C	< 2
Curie Temperature	T _c	°C				160
Resistivity	ρ	Ωm				0.20
Density	d	g/cm ³				4.85

Note: Material characteristics are typical for a toroid core.
Product specification will differ from these data due to the influence of geometry and size.

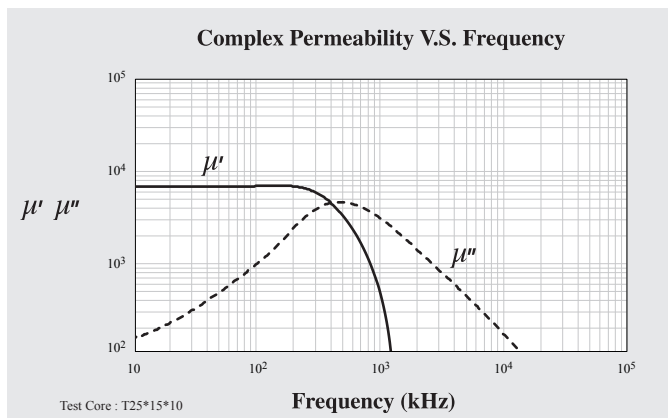
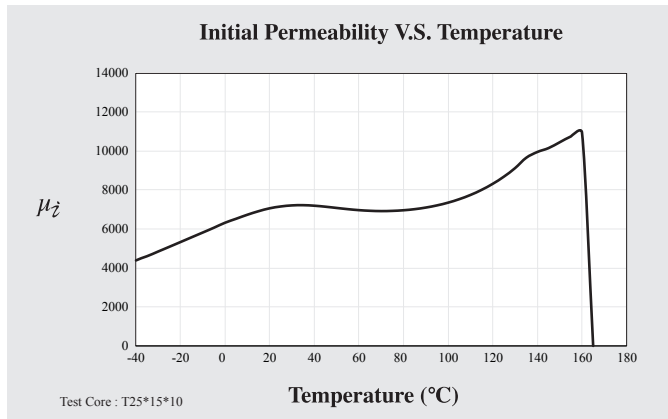
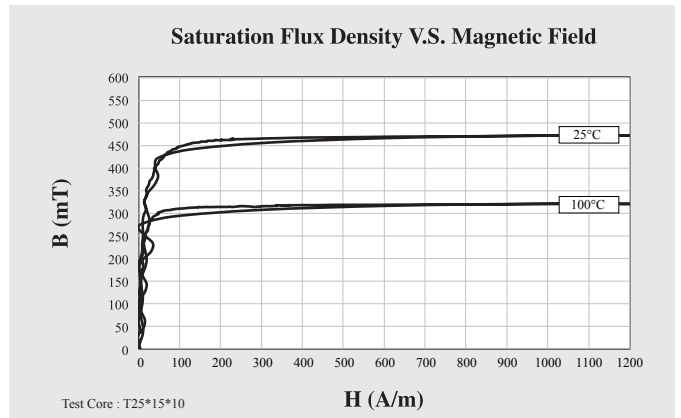
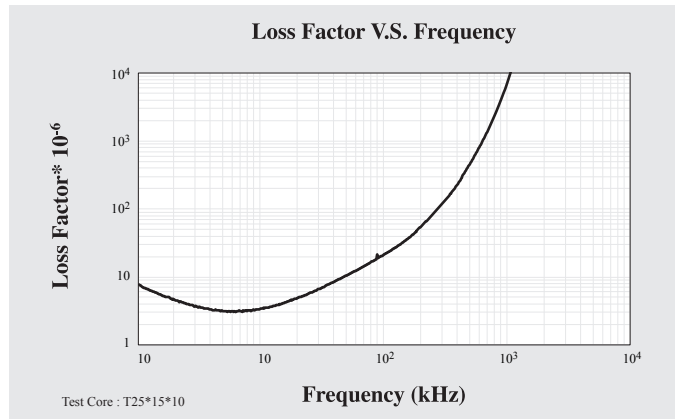

	Symbol	Unit	Measuring Conditions			High Permeability Material
			Freq.	Flux den.	Temp.	A07
Initial Permeability	μ_z		$\leq 10\text{kHz}$	0.25mT	25°C	7000 \pm 25%
Relative Loss Factor	$\tan\delta/\mu_z$	10^{-6}	10kHz	$< 0.25\text{mT}$	25°C	< 8
			100kHz		25°C	< 30
Saturation Flux Density	Bms	mT	10kHz	H = 1200A/m	25°C	400
					100°C	200
Remanence	Brms	mT	10kHz	H = 1200A/m	25°C	150
					100°C	110
Temperature Factor of Permeability	α_F	$10^{-6}/^\circ\text{C}$	10kHz	$< 0.25\text{ mT}$	0 ~ 20°C	-1 ~ 1
					20 ~ 70°C	-1 ~ 1
Hysteresis Material Constant	η_B	$10^{-6}/\text{mT}$	10kHz	1.5-3.0mT	25°C	< 1.2
Disaccommodation Factor	D _F	10^{-6}	10kHz	$< 0.25\text{ mT}$	25°C	< 2
Curie Temperature	T _c	°C				130
Resistivity	ρ	Ωm				0.35
Density	d	g/cm^3				4.90

Note: Material characteristics are typical for a toroid core.
 Product specification will differ from these data due to the influence of geometry and size.

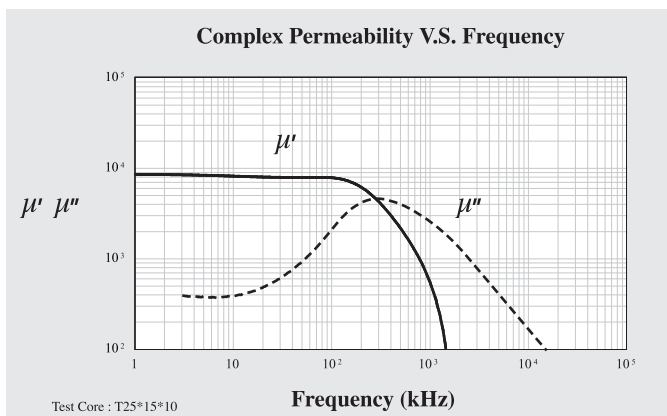
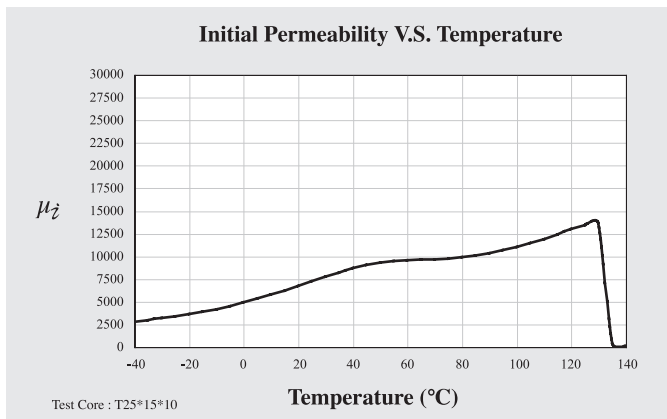
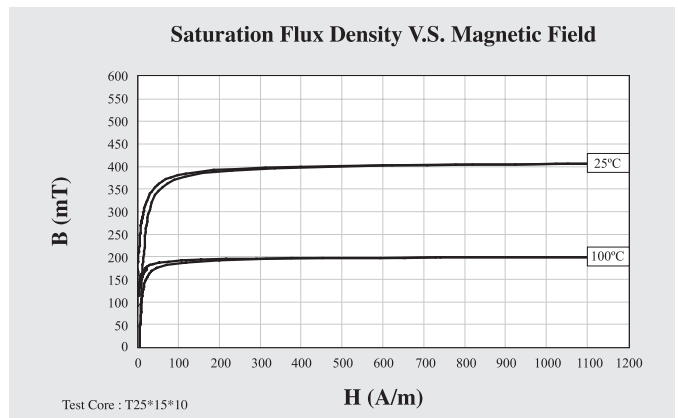
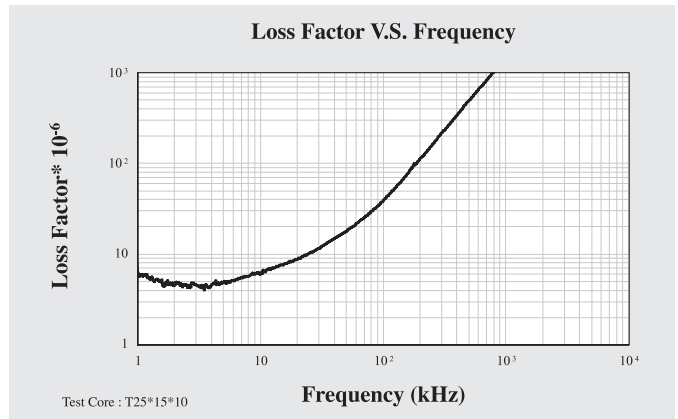

	Symbol	Unit	Measuring Conditions			High Permeability Material
			Freq.	Flux den.	Temp.	A10
Initial Permeability	μ_z		$\leq 10\text{kHz}$	0.25mT	25°C	10000 \pm 30%
Relative Loss Factor	$\tan\delta/\mu_z$	10^{-6}	10kHz	< 0.25mT	25°C	< 10
			100kHz		25°C	< 60
Saturation Flux Density	Bms	mT	10kHz	H = 1200A/m	25°C	410
					100°C	210
Remanence	Brms	mT	10kHz	H = 1200A/m	25°C	140
					100°C	110
Temperature Factor of Permeability	α_F	$10^{-6}/^\circ\text{C}$	10kHz	< 0.25 mT	0 ~ 20°C	0 ~ 1.5
					20 ~ 70°C	-0.5 ~ 1
Hysteresis Material Constant	η_B	$10^{-6}/\text{mT}$	10kHz	1.5-3.0mT	25°C	< 0.5
Disaccommodation Factor	D _F	10^{-6}	10kHz	< 0.25 mT	25°C	< 2
Curie Temperature	T _c	°C				130
Resistivity	ρ	Ωm				0.15
Density	d	g/cm^3				4.90

Note: Material characteristics are typical for a toroid core.
 Product specification will differ from these data due to the influence of geometry and size.

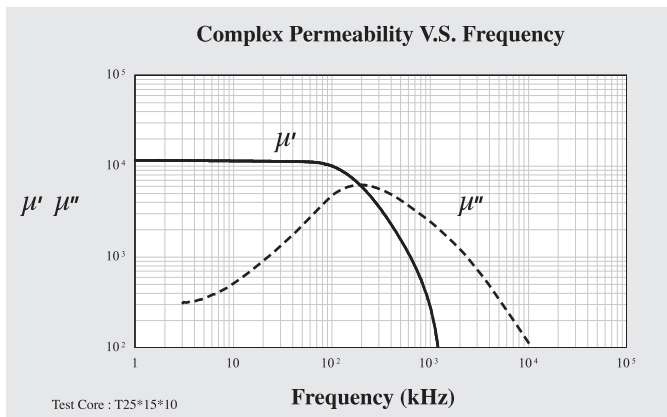
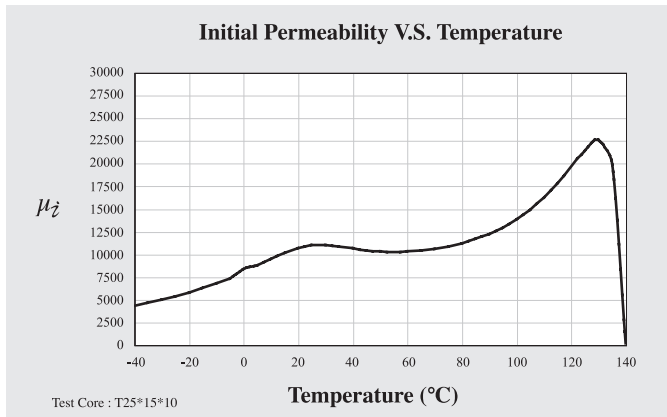
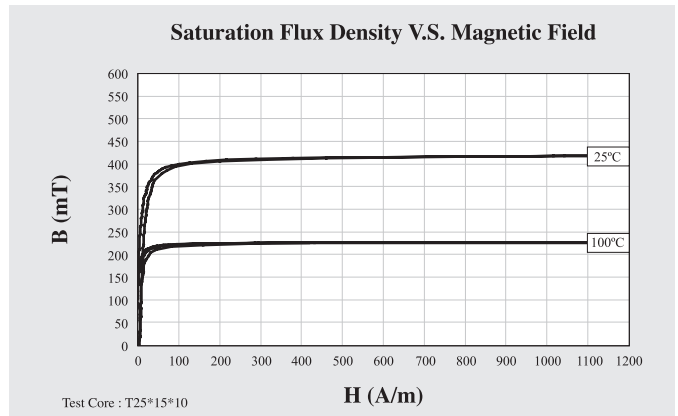
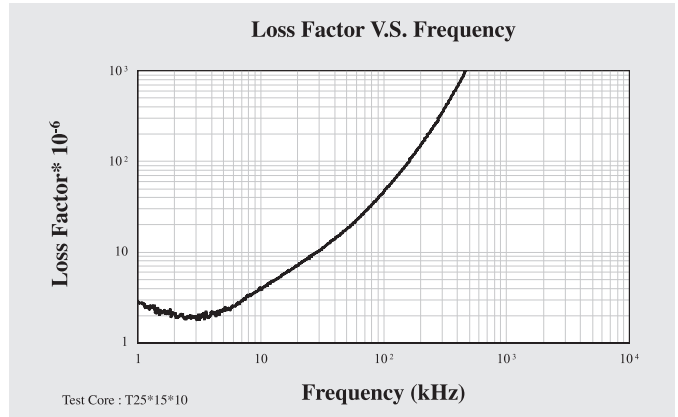

	Symbol	Unit	Measuring Conditions			High Permeability Material
			Freq.	Flux den.	Temp.	A102
Initial Permeability	μ_z		$\leq 10\text{kHz}$	0.25mT	25°C	10000 \pm 30%
Relative Loss Factor	$\tan\delta/\mu_z$	10^{-6}	10kHz	$< 0.25\text{mT}$	25°C	< 10
			100kHz		25°C	< 60
Saturation Flux Density	Bms	mT	10kHz	H = 1200A/m	25°C	380
					100°C	180
Remanence	Brms	mT	10kHz	H = 1200A/m	25°C	95
					100°C	75
Temperature Factor of Permeability	α_F	$10^{-6}/^\circ\text{C}$	10kHz	$< 0.25\text{ mT}$	0 ~ 20°C	-1 ~ 1
					20 ~ 70°C	-1 ~ 1
Hysteresis Material Constant	η_B	$10^{-6}/\text{mT}$	10kHz	1.5-3.0mT	25°C	< 1
Disaccommodation Factor	D _F	10^{-6}	10kHz	$< 0.25\text{ mT}$	25°C	< 2
Curie Temperature	T _c	°C				120
Resistivity	ρ	Ωm				0.15
Density	d	g/cm^3				4.90

Remark: Best impedance, and permeability v. s. frequency performance for 10,000 μ_z materials.

Note: Material characteristics are typical for a toroid core.

Product specification will differ from these data due to the influence of geometry and size.

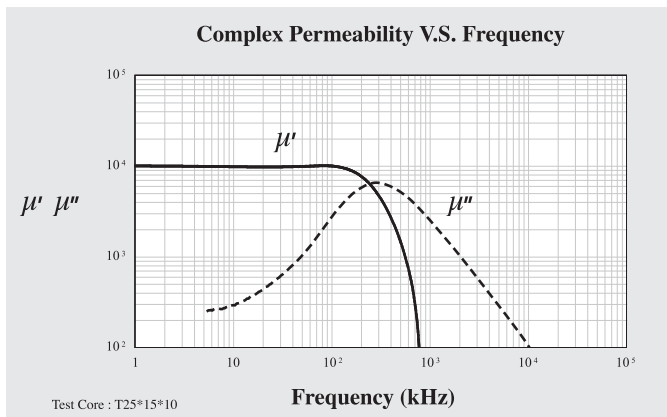
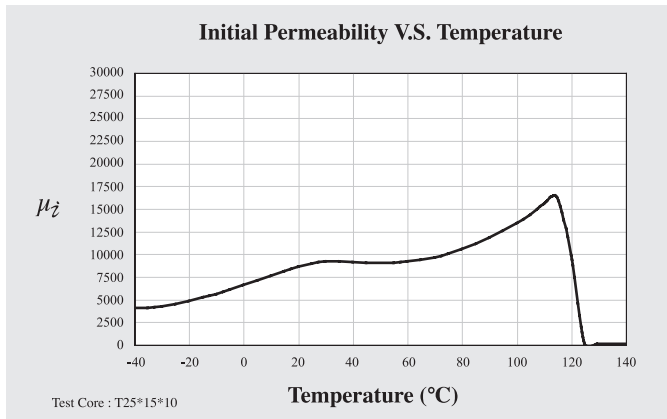
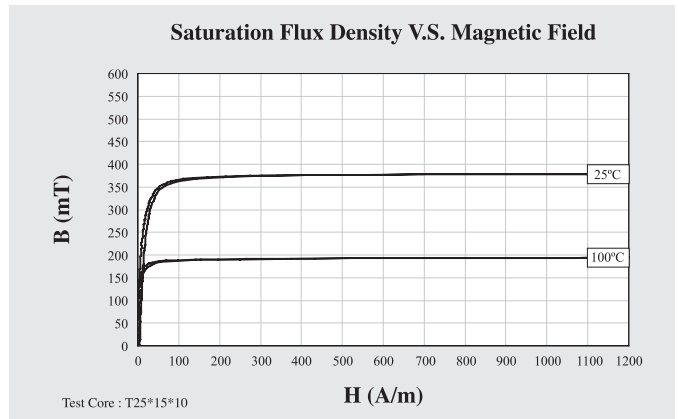
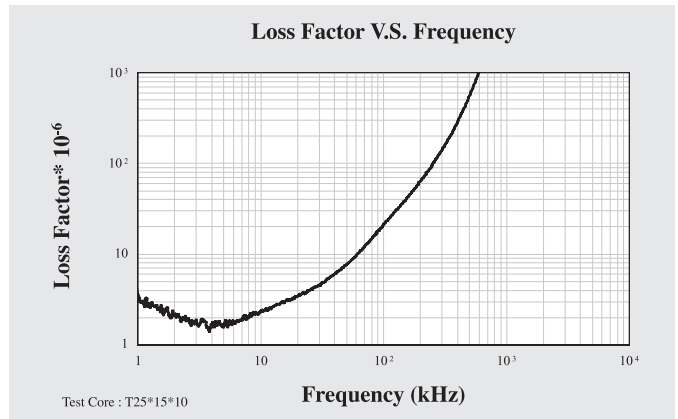

	Symbol	Unit	Measuring Conditions			High Permeability Material
			Freq.	Flux den.	Temp.	A121
Initial Permeability	μ_z		$\leq 10\text{kHz}$	0.25mT	25°C	12000 \pm 30%
Relative Loss Factor	$\tan\delta/\mu_z$	10^{-6}	10kHz	$< 0.25\text{mT}$	25°C	< 10
			100kHz		25°C	< 60
Saturation Flux Density	Bms	mT	10kHz	H = 1200A/m	25°C	380
					100°C	180
Remanence	Brms	mT	10kHz	H = 1200A/m	25°C	130
					100°C	110
Temperature Factor of Permeability	α_F	$10^{-6}/^\circ\text{C}$	10kHz	$< 0.25\text{ mT}$	0 ~ 20°C	0 ~ 1.5
					20 ~ 70°C	-0.5 ~ 1
Hysteresis Material Constant	η_B	$10^{-6}/\text{mT}$	10kHz	1.5-3.0mT	25°C	< 0.5
Disaccommodation Factor	D _F	10^{-6}	10kHz	$< 0.25\text{ mT}$	25°C	< 2
Curie Temperature	T _c	°C				110
Resistivity	ρ	Ωm				0.12
Density	d	g/cm^3				4.90

Note: Material characteristics are typical for a toroid core.
 Product specification will differ from these data due to the influence of geometry and size.

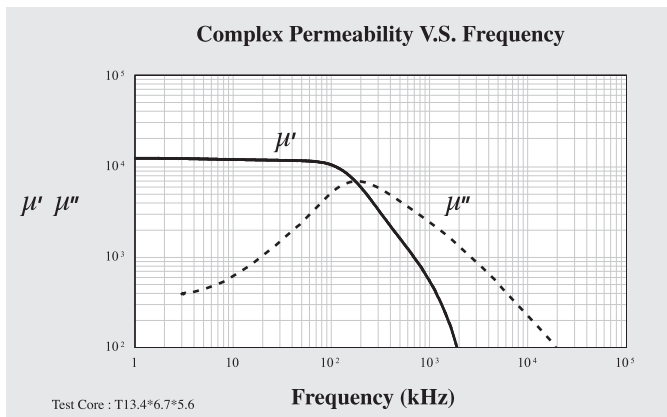
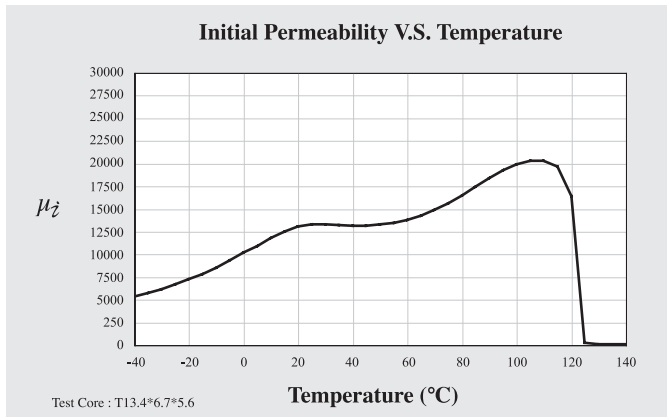
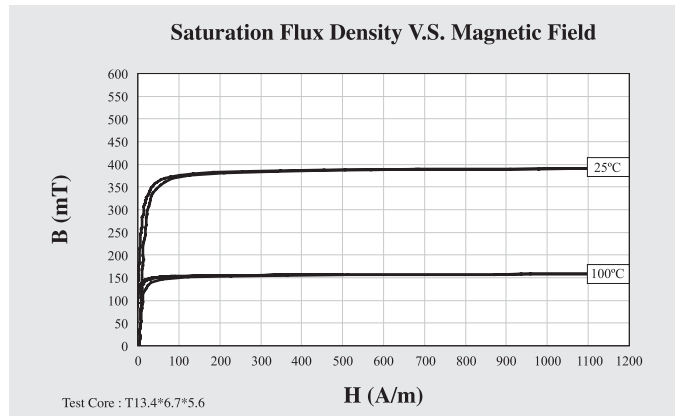
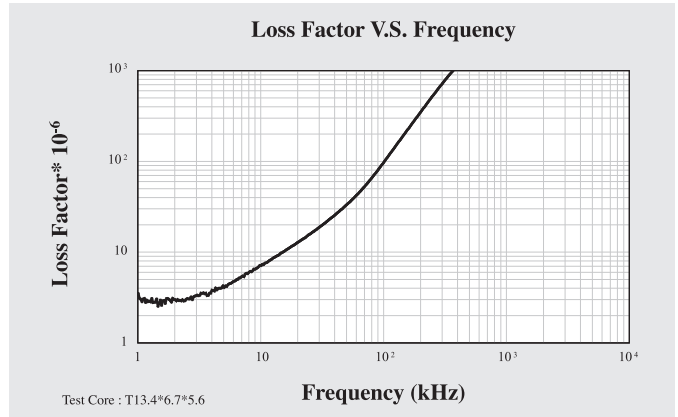

	Symbol	Unit	Measuring Conditions			High Permeability Material
			Freq.	Flux den.	Temp.	A151
Initial Permeability	μ_z		$\leq 10\text{kHz}$	0.25mT	25°C	15000 \pm 30%
Relative Loss Factor	$\tan\delta/\mu_z$	10^{-6}	10kHz	$< 0.25\text{mT}$	25°C	< 10
			100kHz		25°C	< 110
Saturation Flux Density	Bms	mT	10kHz	H = 1200A/m	25°C	400
					100°C	170
Remanence	Brms	mT	10kHz	H = 1200A/m	25°C	220
					100°C	100
Temperature Factor of Permeability	α_F	$10^{-6}/^\circ\text{C}$	10kHz	$< 0.25\text{ mT}$	0 ~ 20°C	-1 ~ 1
					20 ~ 70°C	-1 ~ 1
Hysteresis Material Constant	η_B	$10^{-6}/\text{mT}$	10kHz	1.5-3.0mT	25°C	< 0.5
Disaccommodation Factor	D _F	10^{-6}	10kHz	$< 0.25\text{ mT}$	25°C	< 2
Curie Temperature	T _c	°C				110
Resistivity	ρ	Ωm				0.10
Density	d	g/cm^3				5.00

Note: Material characteristics are typical for a toroid core.
Product specification will differ from these data due to the influence of geometry and size.

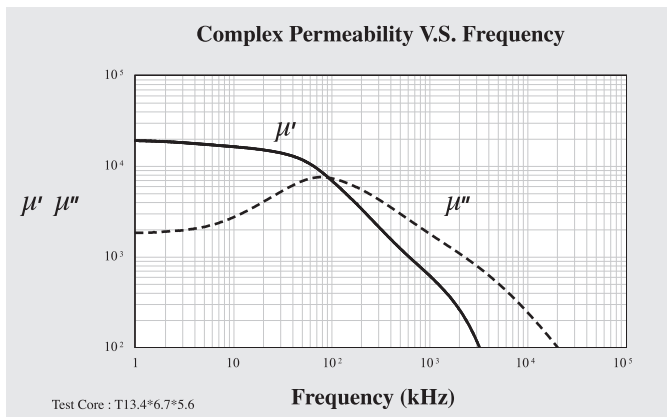
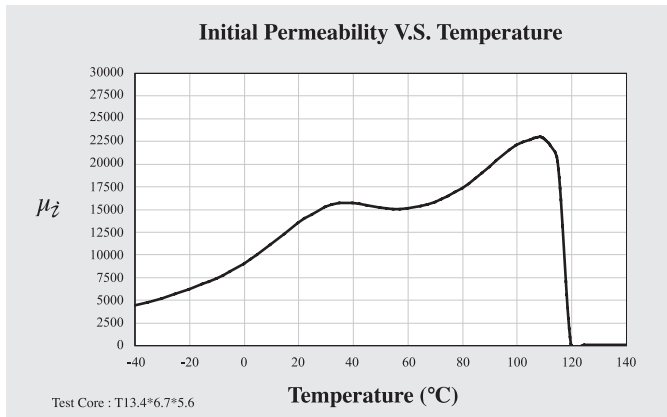
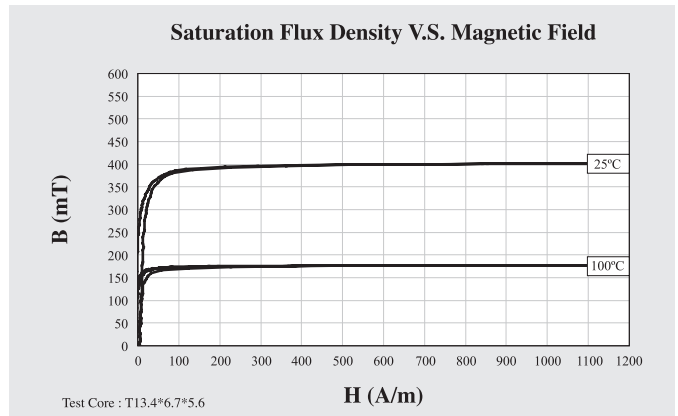
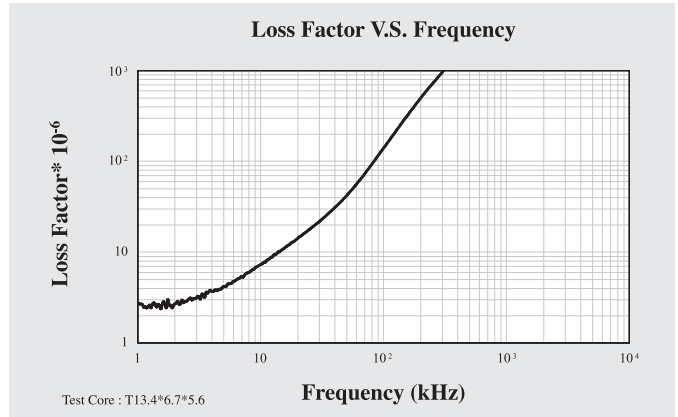

	Symbol	Unit	Measuring Conditions			Telecom High Permeability Material
			Freq.	Flux den.	Temp.	N07
Initial Permeability	μ_z		$\leq 10\text{kHz}$	0.25mT	25°C	7000 \pm 25%
Relative Loss Factor	$\tan\delta/\mu_z$	10 ⁻⁶	10kHz	< 0.25mT	25°C	< 5
			100kHz		25°C	< 30
Saturation Flux Density	Bms	mT	10kHz	H = 1200A/m	25°C	400
					100°C	220
Remanence	Brms	mT	10kHz	H = 1200A/m	25°C	70
					100°C	60
Temperature Factor of Permeability	α_F	10 ⁻⁶ /°C	10kHz	< 0.25 mT	0 ~ 20°C	-1 ~ 1
					20 ~ 70°C	-1 ~ 1
Hysteresis Material Constant	η_B	10 ⁻⁶ /mT	10kHz	1.5-3.0mT	25°C	< 0.2
Disaccommodation Factor	D _F	10 ⁻⁶	10kHz	< 0.25 mT	25°C	< 2
Curie Temperature	T _c	°C				130
Resistivity	ρ	Ωm				0.15
Density	d	g/cm ³				4.90

Note: Material characteristics are typical for a toroid core.
Product specification will differ from these data due to the influence of geometry and size.

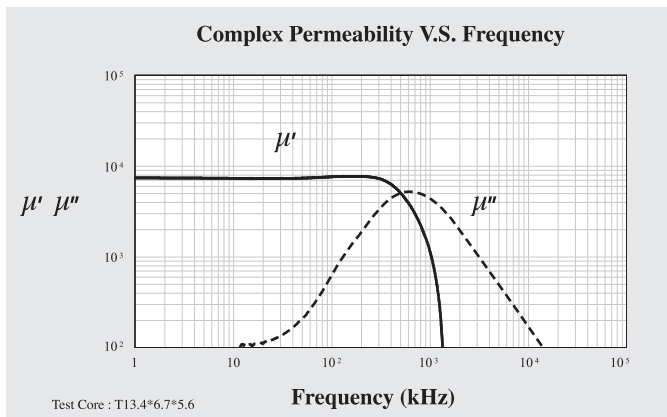
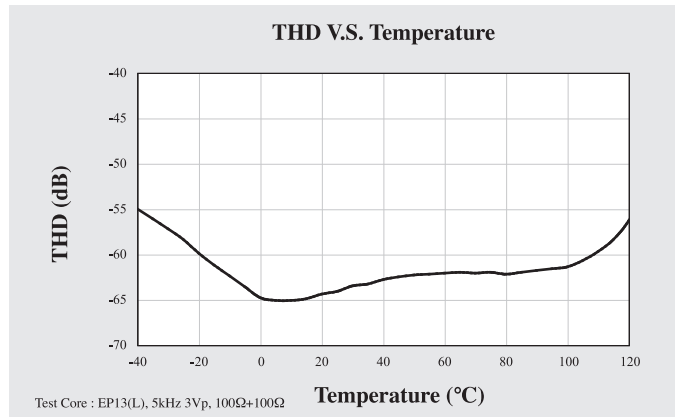
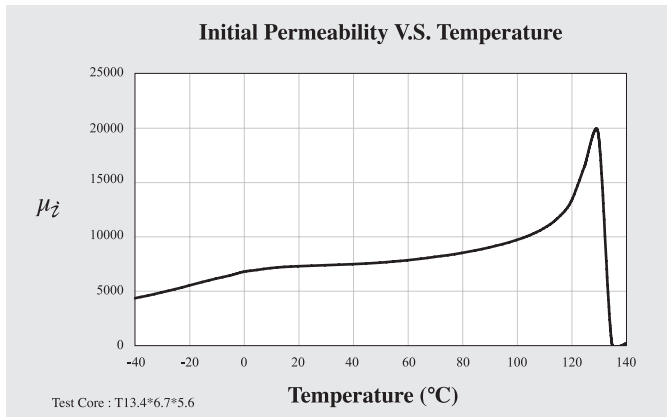
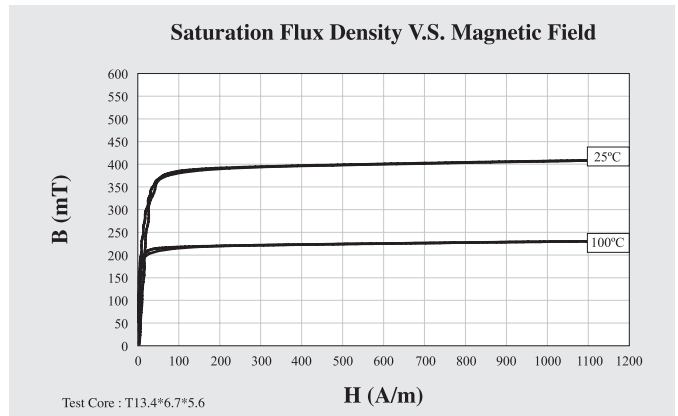
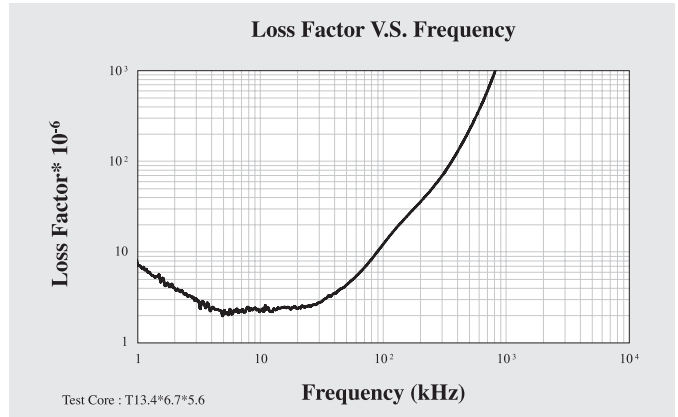

	Symbol	Unit	Measuring Conditions			Telecom Temperature and High Permeability Material
			Freq.	Flux den.	Temp.	N10
Initial Permeability	μ_z		$\leq 10\text{kHz}$	0.25mT	25°C	10000 \pm 30%
					-20°C	> 9000
Relative Loss Factor	$\tan\delta/\mu_z$	10^{-6}	10kHz	< 0.25mT	25°C	< 10
					100kHz	25°C
Saturation Flux Density	Bms	mT	10kHz	H = 1200A/m	25°C	380
					100°C	160
Remanence	Brms	mT	10kHz	H = 1200A/m	25°C	160
					100°C	110
Temperature Factor of Permeability	α_F	$10^{-6}/^\circ\text{C}$	10kHz	< 0.25 mT	0 ~ 20°C	-1 ~ 0
					20 ~ 70°C	-1 ~ 1
Hysteresis Material Constant	η_B	$10^{-6}/\text{mT}$	10kHz	1.5-3.0mT	25°C	< 0.5
Disaccommodation Factor	D _F	10^{-6}	10kHz	< 0.25 mT	25°C	< 2
Curie Temperature	T _c	°C				100
Resistivity	ρ	Ωm				0.12
Density	d	g/cm^3				5.00

Note: Material characteristics are typical for a toroid core.
 Product specification will differ from these data due to the influence of geometry and size.

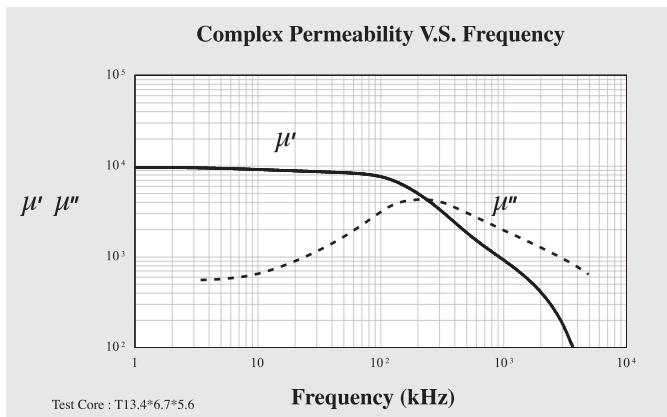
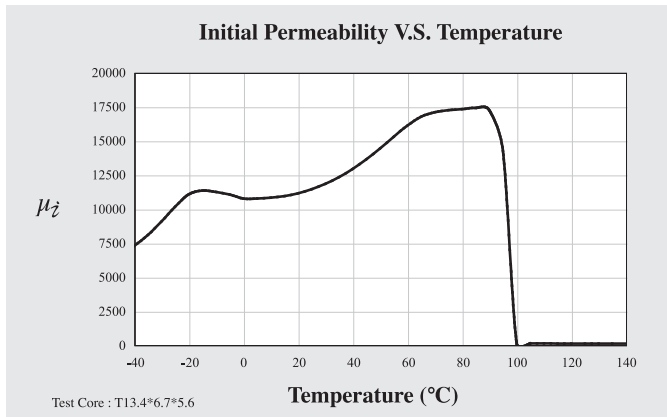
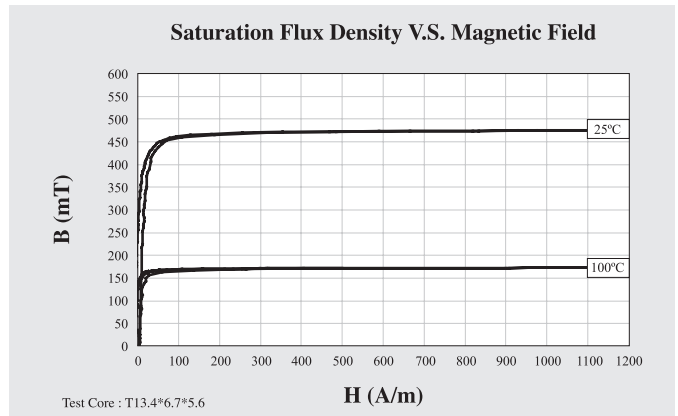
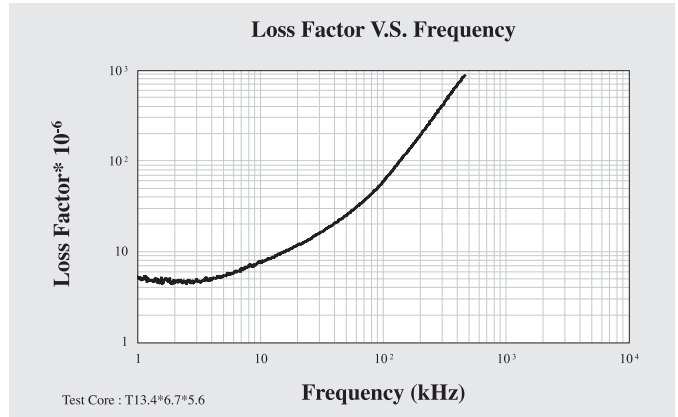

	Symbol	Unit	Measuring Conditions			Telecom High Permeability Material
			Freq.	Flux den.	Temp.	A043
Initial Permeability	μ_i		$\leq 10\text{kHz}$	0.25mT	25°C	4500 \pm 25%
Relative Loss Factor	$\tan\delta/\mu_i$	10^{-6}	10kHz	$< 0.25\text{mT}$	25°C	< 10
			100kHz		25°C	< 10
Saturation Flux Density	Bms	mT	10kHz	H = 1200A/m	25°C	460
					100°C	300
Remanence	Brms	mT	10kHz	H = 1200A/m	25°C	65
					100°C	60
Temperature Factor of Permeability	α_F	$10^{-6}/^\circ\text{C}$	10kHz	$< 0.25\text{ mT}$	0 ~ 20°C	1 ~ 2
					20 ~ 70°C	-1 ~ 1
Hysteresis Material Constant	η_B	$10^{-6}/\text{mT}$	10kHz	1.5-3.0mT	25°C	< 0.5
Disaccommodation Factor	D _F	10^{-6}	10kHz	$< 0.25\text{ mT}$	25°C	< 2
Curie Temperature	T _c	°C				160
Resistivity	ρ	Ωm				0.20
Density	d	g/cm ³				4.85

Note: Material characteristics are typical for a toroid core.
Product specification will differ from these data due to the influence of geometry and size.

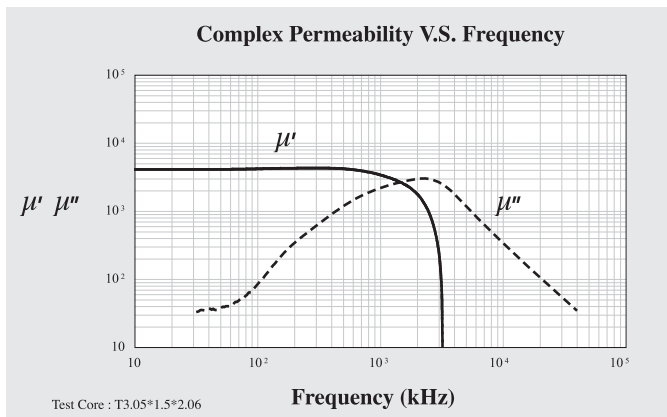
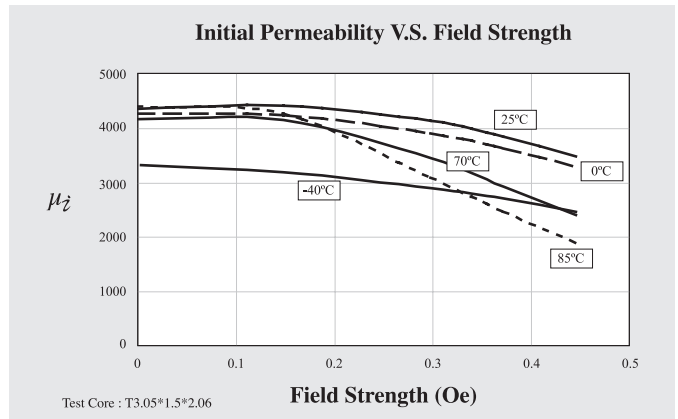
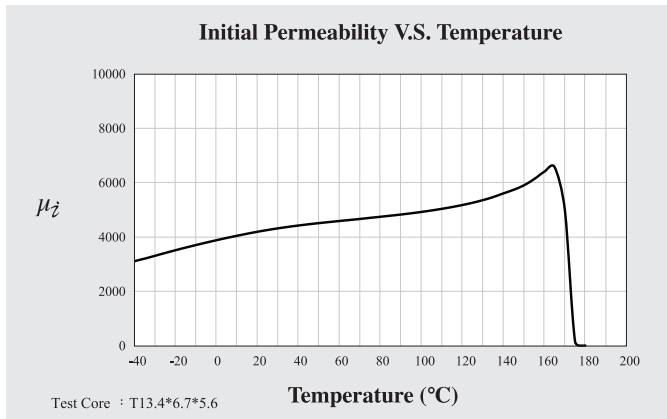
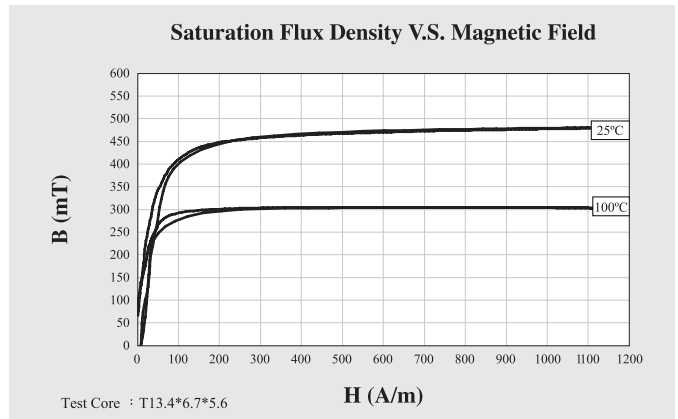
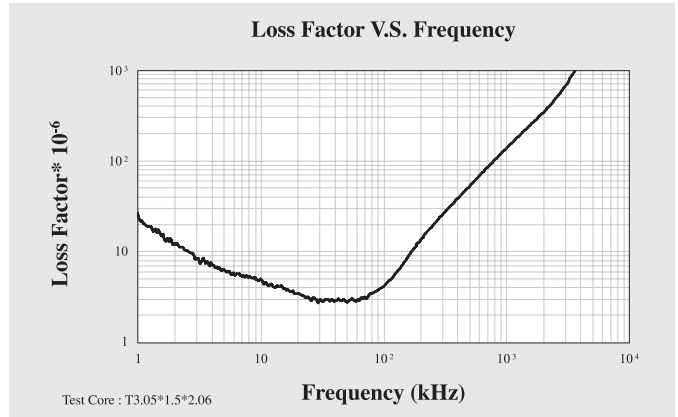

	Symbol	Unit	Measuring Conditions			Telecom High Permeability Material
			Freq.	Flux den.	Temp.	A061
Initial Permeability	μ_i		$\leq 10\text{kHz}$	0.25mT	25°C	6000 \pm 25%
Relative Loss Factor	$\tan\delta/\mu_i$	10^{-6}	10kHz	$< 0.25\text{mT}$	25°C	< 10
			100kHz		25°C	< 15
Saturation Flux Density	Bms	mT	10kHz	H = 1200A/m	25°C	460
					100°C	300
Remanence	Brms	mT	10kHz	H = 1200A/m	25°C	65
					100°C	60
Temperature Factor of Permeability	α_F	$10^{-6}/^\circ\text{C}$	10kHz	$< 0.25\text{ mT}$	0 ~ 20°C	1 ~ 2
					20 ~ 70°C	-1 ~ 1
Hysteresis Material Constant	η_B	$10^{-6}/\text{mT}$	10kHz	1.5-3.0mT	25°C	< 0.5
Disaccommodation Factor	D _F	10^{-6}	10kHz	$< 0.25\text{ mT}$	25°C	< 2
Curie Temperature	T _c	°C				160
Resistivity	ρ	Ωm				0.20
Density	d	g/cm^3				4.85

Note: Material characteristics are typical for a toroid core.
Product specification will differ from these data due to the influence of geometry and size.

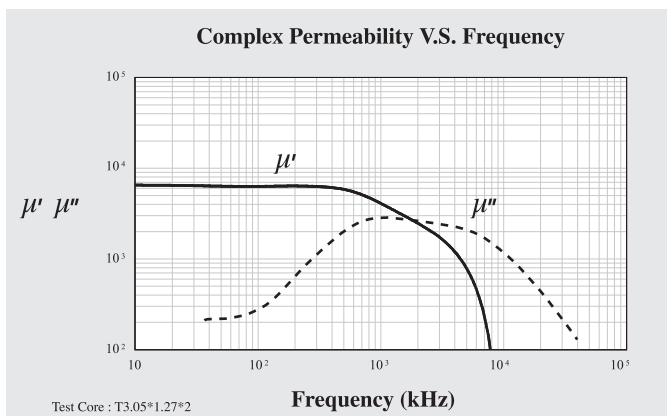
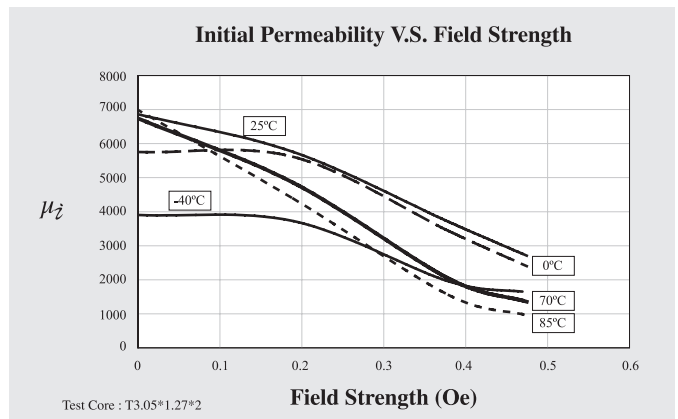
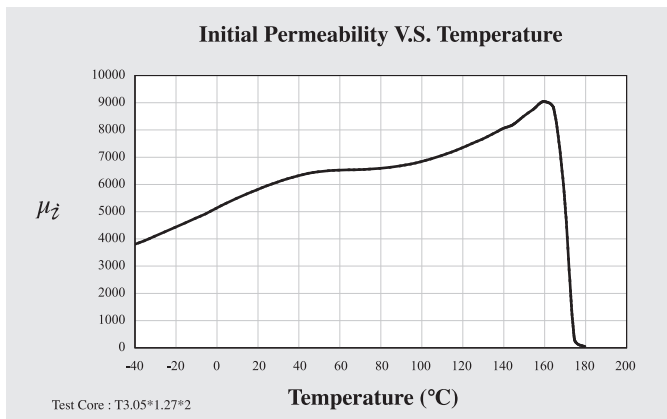
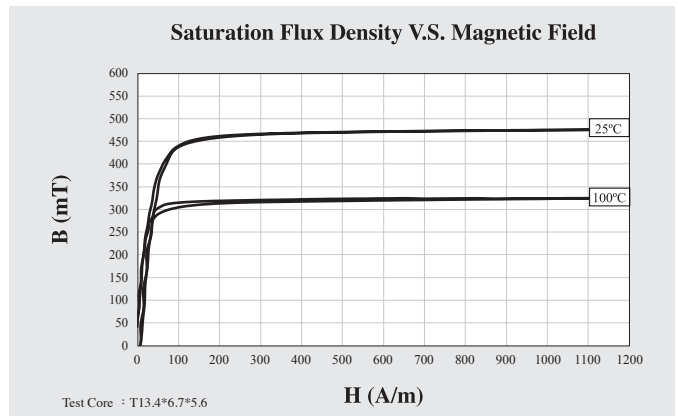
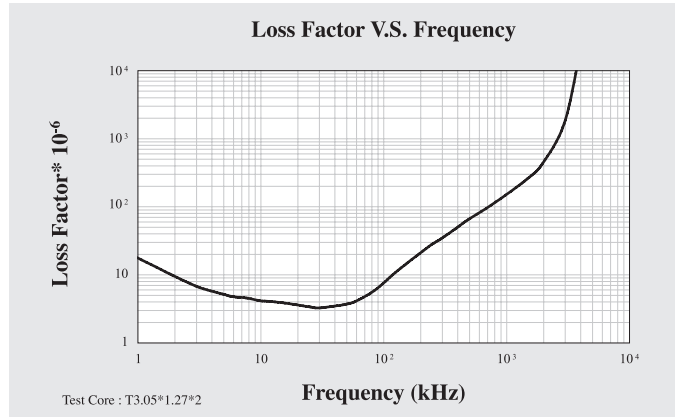

	Symbol	Unit	Measuring Conditions			THD High Permeability Material
			Freq.	Flux den.	Temp.	A101
Initial Permeability	μ_z		$\leq 10\text{kHz}$	0.25mT	25°C	10000 \pm 30%
Relative Loss Factor	$\tan\delta/\mu_z$	10 ⁻⁶	10kHz	< 0.25mT	25°C	< 10
			100kHz		25°C	< 90
Saturation Flux Density	Bms	mT	10kHz	H = 1200A/m	25°C	400
					100°C	220
Remanence	Brms	mT	10kHz	H = 1200A/m	25°C	175
					100°C	125
Temperature Factor of Permeability	α_F	10 ⁻⁶ /°C	10kHz	< 0.25 mT	0 ~ 20°C	-1 ~ 1
					20 ~ 70°C	-1 ~ 1
Hysteresis Material Constant	η_B	10 ⁻⁶ /mT	10kHz	1.5-3.0mT	25°C	< 0.2
Disaccommodation Factor	D _F	10 ⁻⁶	10kHz	< 0.25 mT	25°C	< 2
Curie Temperature	T _c	°C				130
Resistivity	ρ	Ωm				0.15
Density	d	g/cm ³				4.90

Remark: Best THD performance for 10,000 μ_z materials.

Note: Material characteristics are typical for a toroid core.

Product specification will differ from these data due to the influence of geometry and size.

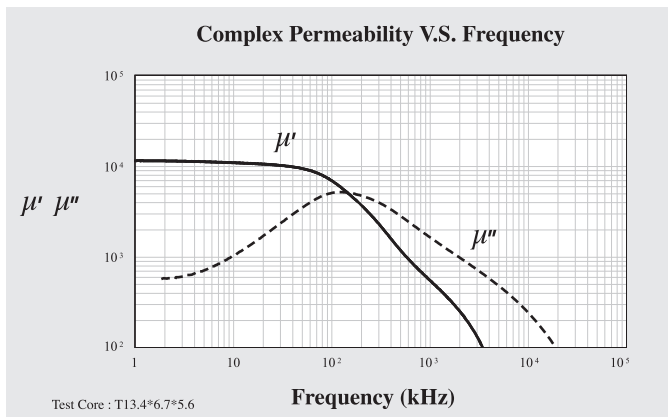
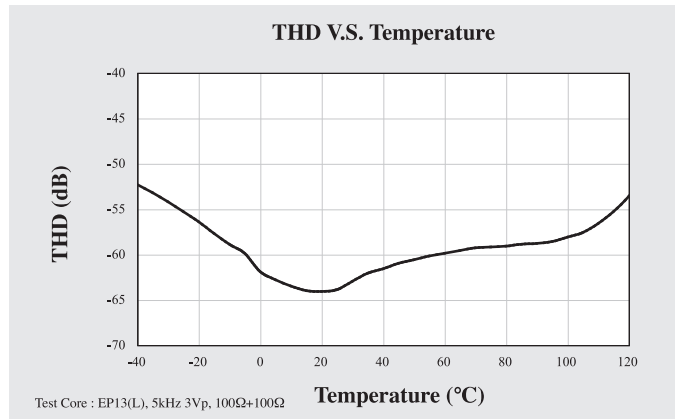
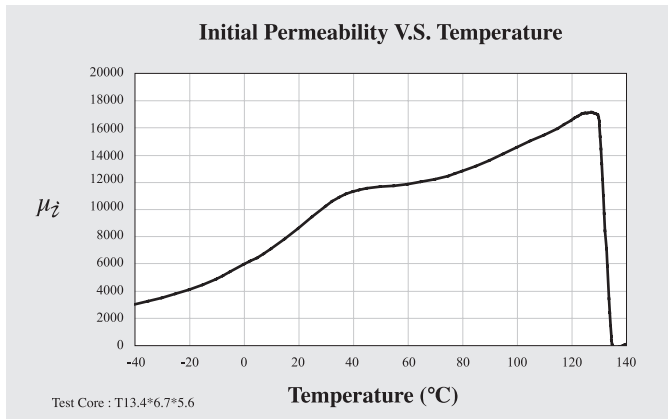
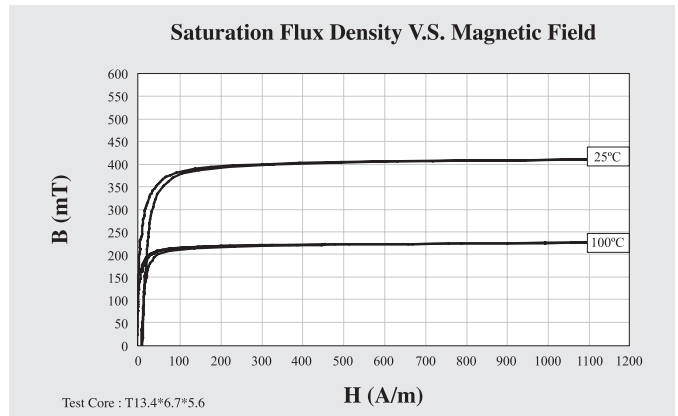
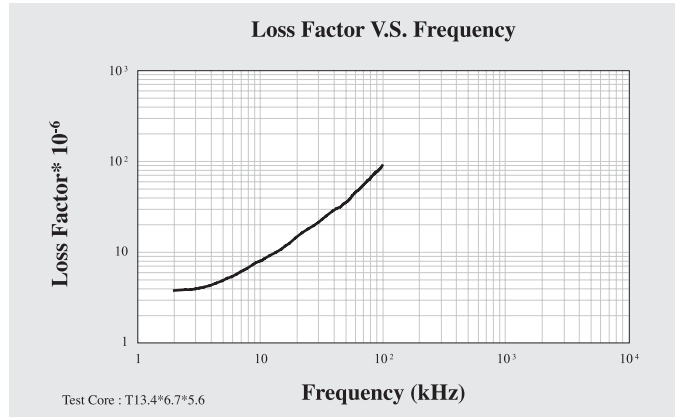

	Symbol	Unit	Measuring Conditions			Telecom High Bs Material
			Freq.	Flux den.	Temp.	N42
Initial Permeability	μ_i		$\leq 10\text{kHz}$	0.25mT	25°C	3800 \pm 25%
Relative Loss Factor	$\tan\delta/\mu_i$	10 ⁻⁶	10kHz	< 0.25mT	25°C	< 1.5
			100kHz		25°C	< 2.5
Saturation Flux Density	B _{ms}	mT	10kHz	H = 1200A/m	25°C	530
					100°C	425
Remanence	B _{rs}	mT	10kHz	H = 1200A/m	25°C	75
					100°C	250
Coercivity	H _c	A/m	10kHz	H = 1200A/m	25°C	7
					100°C	12
Temperature Factor of Permeability	α_F	10 ⁻⁶ /°C	10kHz	< 0.25 mT	5 ~ 25°C	7 ~ 9
					25 ~ 55°C	< -4 ~ -2
Hysteresis Material Constant	η_B	10 ⁻⁶ /mT	10kHz	1.5-3.0mT	25°C	< 0.3
Curie Temperature	T _c	°C	10kHz	< 0.25 mT		250
Resistivity	ρ	Ωm				5.00
Density	d	g/cm ³				4.90

Note: Material characteristics are typical for a toroid core.
 Product specification will differ from these data due to the influence of geometry and size.

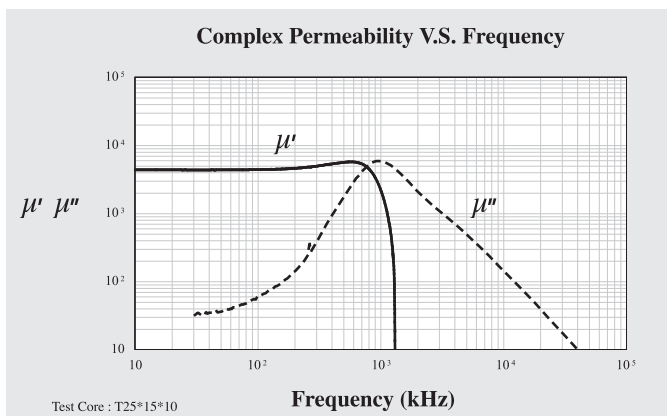
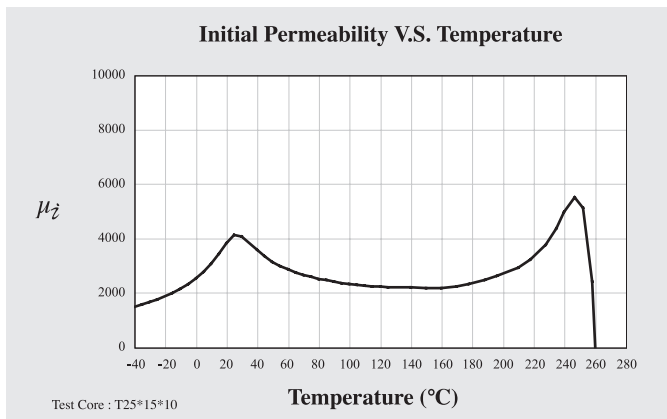
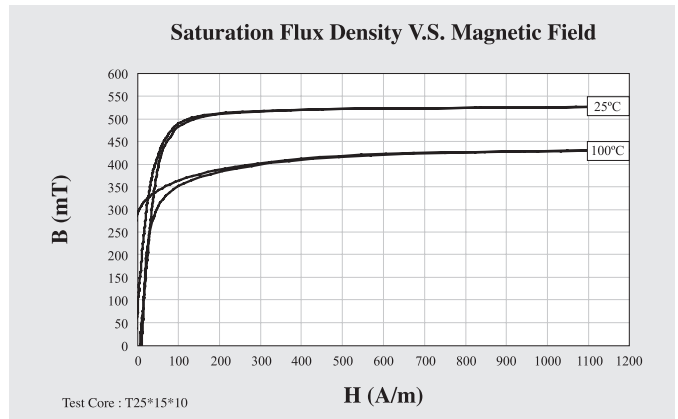
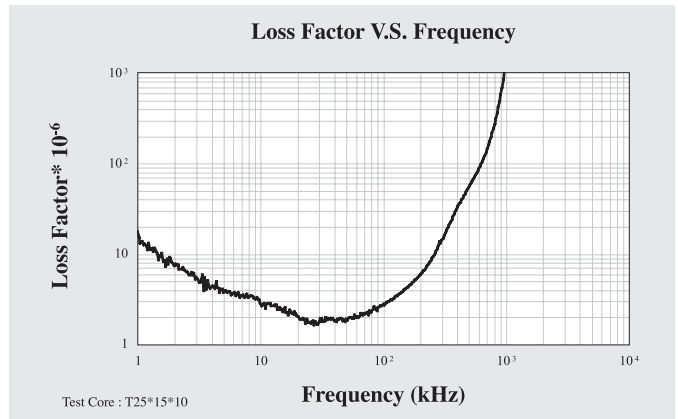

	Symbol	Unit	Measuring Conditions			Senser and Telecom Filter Material
			Freq.	Flux den.	Temp.	N4
Initial Permeability	μ_i		$\leq 10\text{kHz}$	0.25mT	25°C	2500 \pm 25%
Relative Loss Factor	$\tan\delta/\mu_i$	10 ⁻⁶	10kHz	< 0.25mT	25°C	< 7
			100kHz		25°C	< 3
Saturation Flux Density	B _{ms}	mT	10kHz	H = 1200A/m	25°C	450
					100°C	320
Remanence	Br _{ms}	mT	10kHz	H = 1200A/m	25°C	90
					100°C	100
Coercivity	H _c	A/m	10kHz	H = 1200A/m	25°C	13
					100°C	11
Temperature Factor of Permeability	α_F	10 ⁻⁶ /°C	10kHz	< 0.25 mT	5 ~ 25°C	< 1.3
					25 ~ 55°C	< 1.3
Hysteresis Material Constant	η_B	10 ⁻⁶ /mT	10kHz	1.5-3.0mT	25°C	< 0.6
Curie Temperature	T _c	°C	10kHz	< 0.25 mT		170
Resistivity	ρ	Ωm				7.50
Density	d	g/cm ³				4.70

Note: Material characteristics are typical for a toroid core.
 Product specification will differ from these data due to the influence of geometry and size.

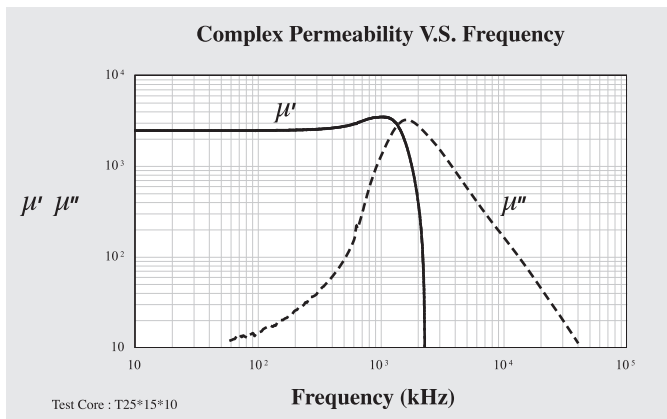
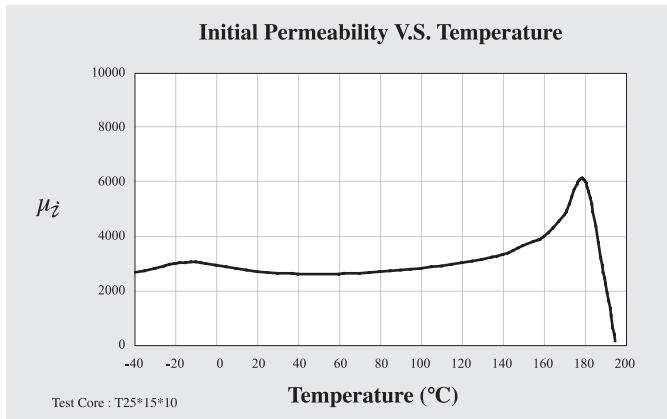
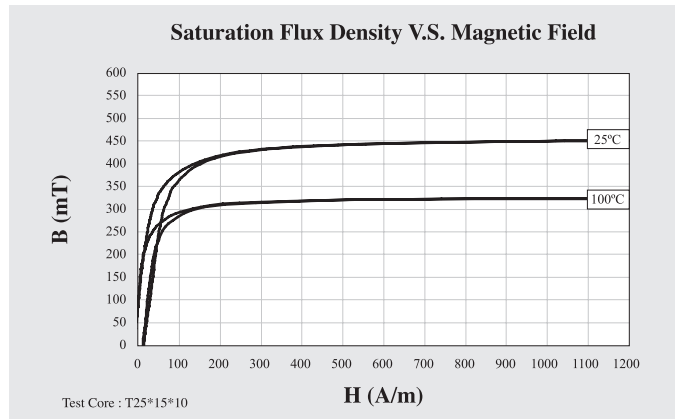
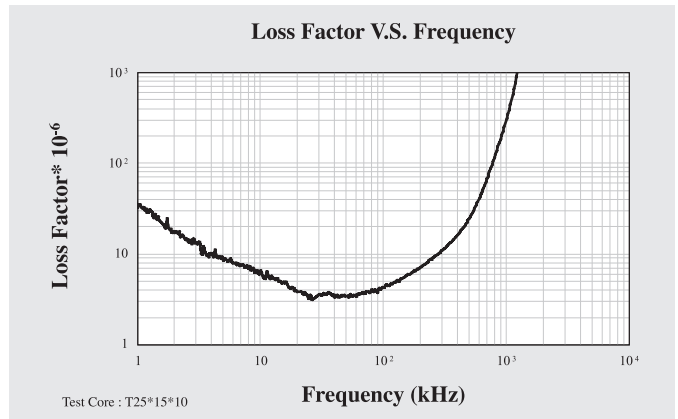

	Symbol	Unit	Measuring Conditions			Senser and Telecom Filter Material
			Freq.	Flux den.	Temp.	N43
Initial Permeability	μ_i		$\leq 10\text{kHz}$	0.25mT	25°C	750 \pm 25%
Relative Loss Factor	$\tan\delta/\mu_i$	10^{-6}	10kHz	$< 0.25\text{mT}$	25°C	< 60
			100kHz		25°C	< 15
Saturation Flux Density	Bms	mT	10kHz	H = 1200A/m	25°C	490
					100°C	400
Remanence	Brms	mT	10kHz	H = 1200A/m	25°C	240
					100°C	190
Coercivity	Hc	A/m	10kHz	H = 1200A/m	25°C	23
					100°C	18
Temperature Factor of Permeability	α_F	$10^{-6}/^\circ\text{C}$	10kHz	$< 0.25\text{ mT}$	5 ~ 25°C	< 2.2
					25 ~ 55°C	< 1.8
Hysteresis Material Constant	η_B	$10^{-6}/\text{mT}$	10kHz	1.5-3.0mT	25°C	$< 2.5^{(100\text{kHz})}$
Curie Temperature	Tc	°C	10kHz	$< 0.25\text{ mT}$		250
Resistivity	ρ	Ωm				2.00
Density	d	g/cm^3				4.70

Note: Material characteristics are typical for a toroid core.
 Product specification will differ from these data due to the influence of geometry and size.

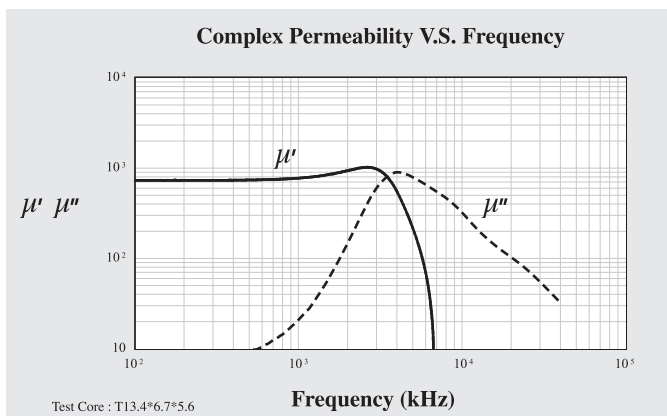
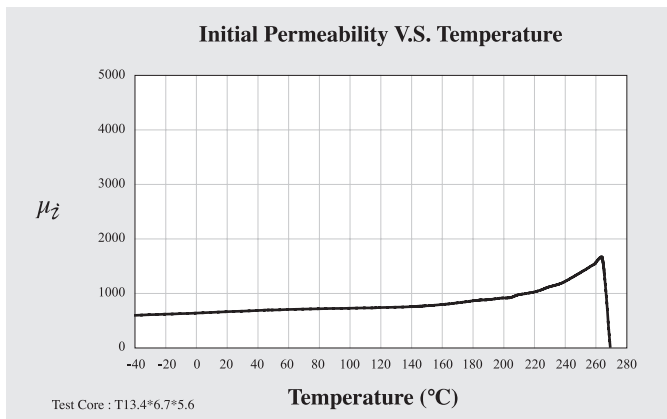
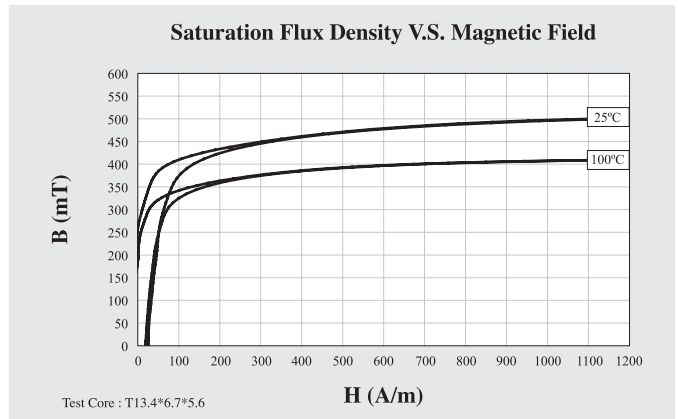
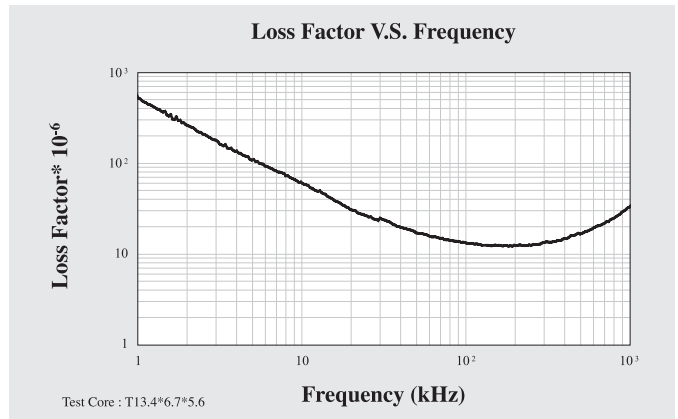

	Symbol	Unit	Measuring Conditions			EMI-Suppression Material
			Freq.	Flux den.	Temp.	N5
Initial Permeability	μ_i		$\leq 10\text{kHz}$	0.25mT	25°C	2000 \pm 25%
Relative Loss Factor	$\tan\delta/\mu_i$	10^{-6}	10kHz	$< 0.25\text{mT}$	25°C	< 1.24
					25°C	< 23
Saturation Flux Density	Bms	mT	10kHz	H = 1200A/m	25°C	370
					100°C	285
Remanence	Brms	mT	10kHz	H = 1200A/m	25°C	240
					100°C	140
Coercivity	Hc	A/m	10kHz	H = 1200A/m	25°C	
					100°C	
Temperature Factor of Permeability	α_F	$10^{-6}/^\circ\text{C}$	10kHz	$< 0.25\text{ mT}$	5 ~ 25°C	< 1.1
					25 ~ 55°C	< 5.8
Hysteresis Material Constant	η_B	$10^{-6}/\text{mT}$	10kHz	1.5-3.0mT	25°C	< 0.36
Curie Temperature	Tc	°C	10kHz	$< 0.25\text{ mT}$		130
Resistivity	ρ	Ωm				140
Density	d	g/cm^3				4.95

Note: Material characteristics are typical for a toroid core.
 Product specification will differ from these data due to the influence of geometry and size.

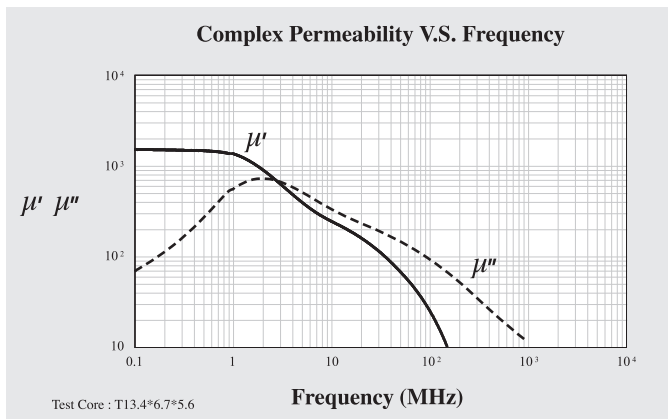
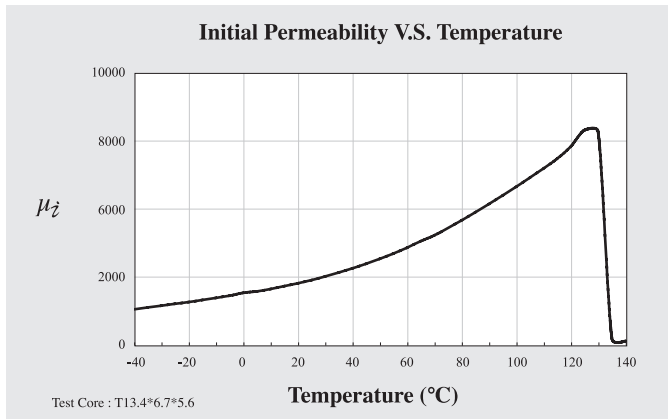
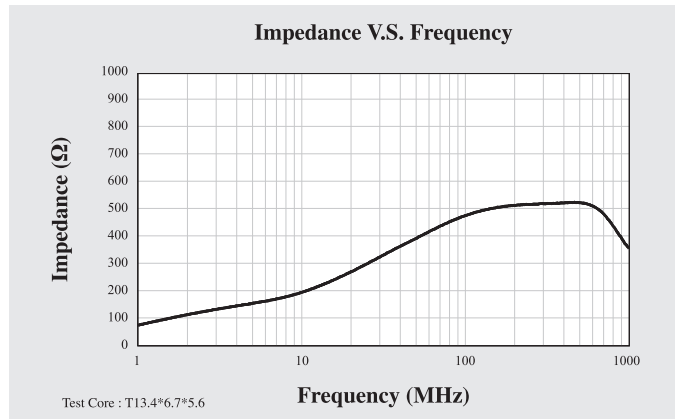
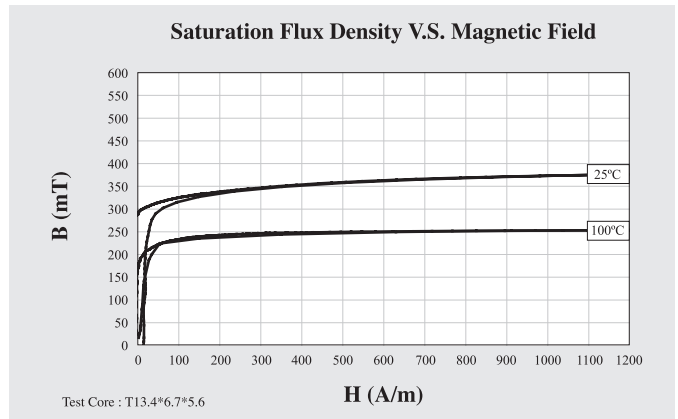

	Symbol	Unit	Measuring Conditions			EMI-Suppression Material
			Freq.	Flux den.	Temp.	N51
Initial Permeability	μ_i		$\leq 10\text{kHz}$	0.25mT	25°C	450 ± 25%
Relative Loss Factor	$\tan\delta/\mu_i$	10^{-6}	10kHz	$< 0.25\text{mT}$	25°C	
			100kHz		25°C	
Saturation Flux Density	Bms	mT	10kHz	H = 1200A/m	25°C	363
					100°C	304
Remanence	Brms	mT	10kHz	H = 1200A/m	25°C	316
					100°C	250
Coercivity	Hc	A/m	10kHz	H = 1200A/m	25°C	70
					100°C	32
Temperature Factor of Permeability	α_F	$10^{-6}/^\circ\text{C}$	10kHz	$< 0.25\text{ mT}$	5 ~ 25°C	< 15
					25 ~ 55°C	< 15
Hysteresis Material Constant	η_B	$10^{-6}/\text{mT}$	10kHz	1.5-3.0mT	25°C	
Curie Temperature	Tc	°C	10kHz	$< 0.25\text{ mT}$		220
Resistivity	ρ	Ωm				10000
Density	d	g/cm^3				4.75

Note: Material characteristics are typical for a toroid core.
 Product specification will differ from these data due to the influence of geometry and size.

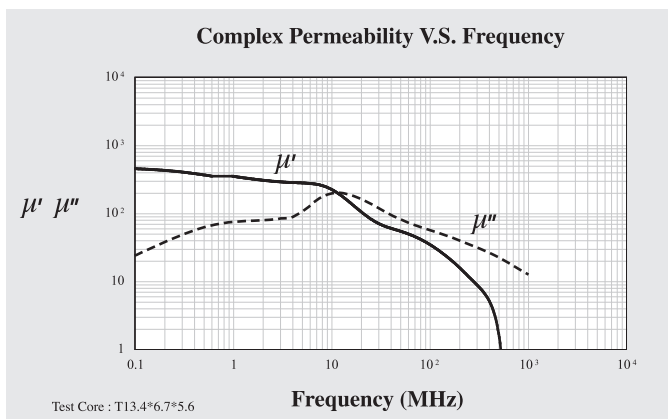
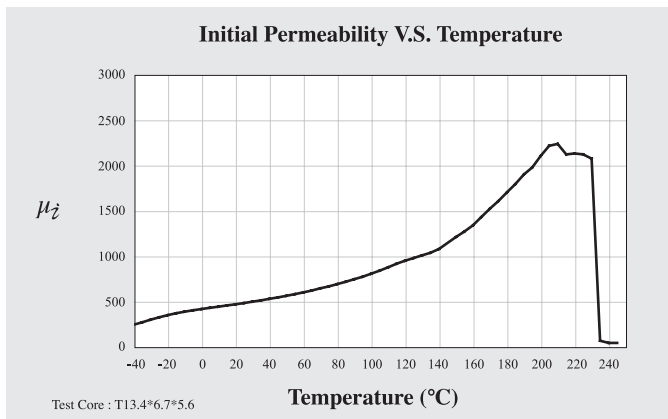
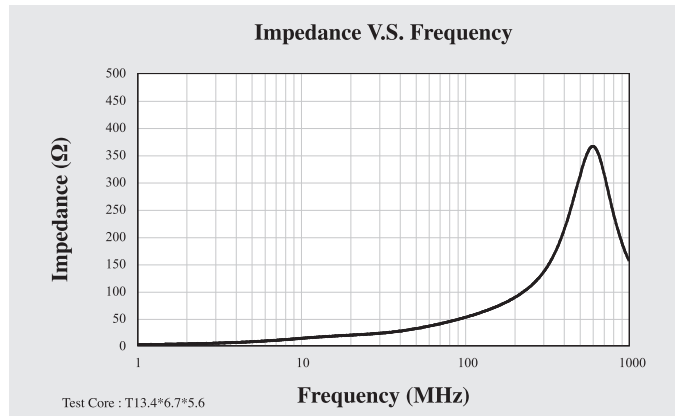
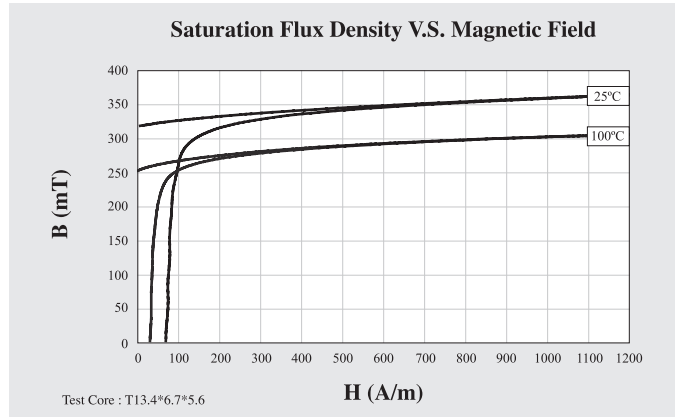

	Symbol	Unit	Measuring Conditions			EMI-Suppression Material
			Freq.	Flux den.	Temp.	K05
Initial Permeability	μ_i		$\leq 10\text{kHz}$	0.25mT	25°C	500 ± 25%
Saturation Flux Density	Bms	mT	1kHz	H = 1200A/m	25°C	380
Remanence	Brms	mT	1kHz	H = 1200A/m	25°C	260
Coercivity	Hc	A/m	1kHz	H = 1200A/m	25°C	80
Relative Loss Factor	$\tan\delta/\mu_i$	10 ⁻⁶	100kHz	< 0.25mT	25°C	100
Temperature Factor of Permeability	α_F	10 ⁻⁶ /°C	10kHz	< 0.25 mT	20 ~ 60°C	15
Curie Temperature	Tc	°C				220
Resistivity	ρ	Ωm				> 10 ⁶
Density	d	g/cm ³				5.10

Note: Material characteristics are typical for a toroid core.
 Product specification will differ from these data due to the influence of geometry and size.

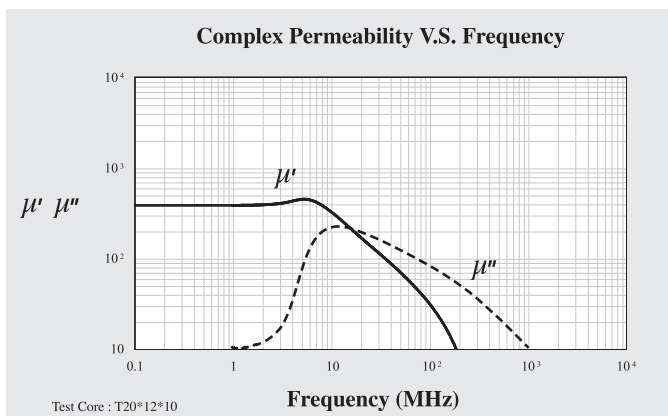
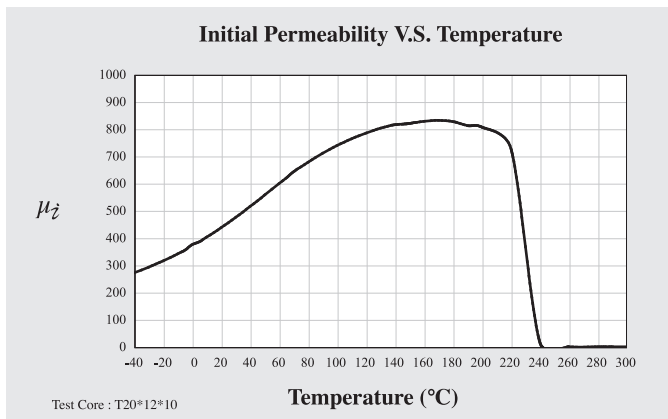
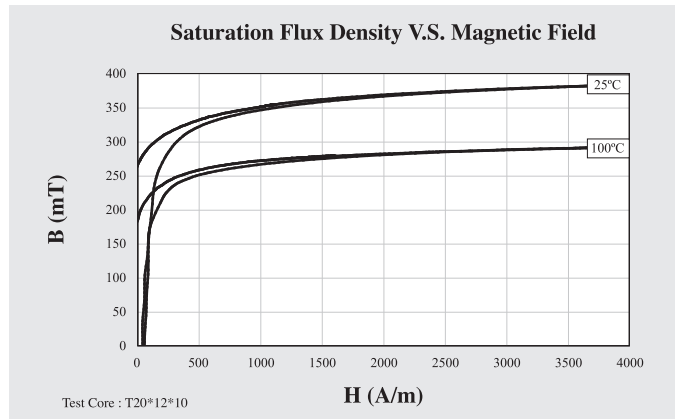
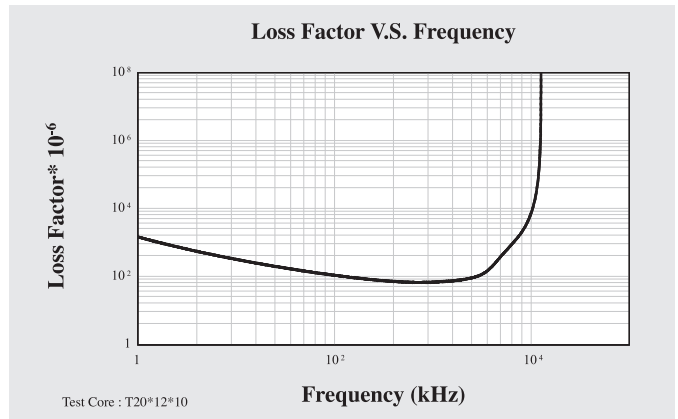

	Symbol	Unit	Measuring Conditions			EMI-Suppression Material
			Freq.	Flux den.	Temp.	K07
Initial Permeability	μ_i		$\leq 10\text{kHz}$	0.25mT	25°C	700 \pm 25%
Saturation Flux Density	Bms	mT	1kHz	H = 1200A/m	25°C	350
Remanence	Brms	mT	1kHz	H = 1200A/m	25°C	195
Coercivity	Hc	A/m	1kHz	H = 1200A/m	25°C	45
Relative Loss Factor	$\tan\delta/\mu_i$	10 ⁻⁶	100kHz	< 0.25mT	25°C	18
Temperature Factor of Permeability	α_F	10 ⁻⁶ /°C	10kHz	< 0.25 mT	20 ~ 60°C	8
Curie Temperature	Tc	°C				180
Resistivity	ρ	Ωm				> 10 ⁶
Density	d	g/cm ³				5.10

Note: Material characteristics are typical for a toroid core.
 Product specification will differ from these data due to the influence of geometry and size.

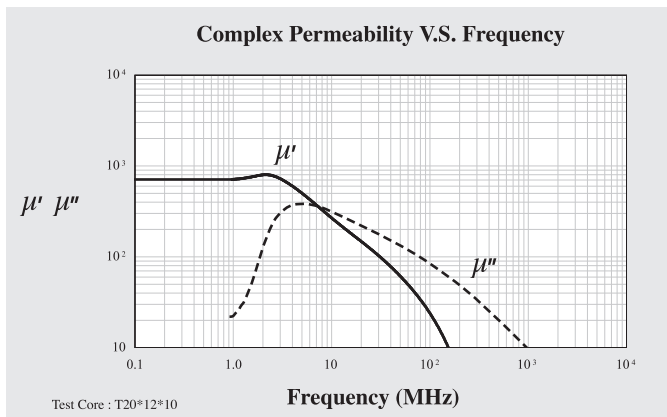
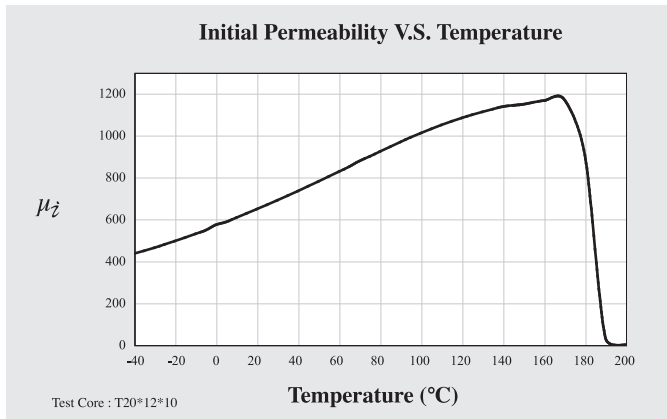
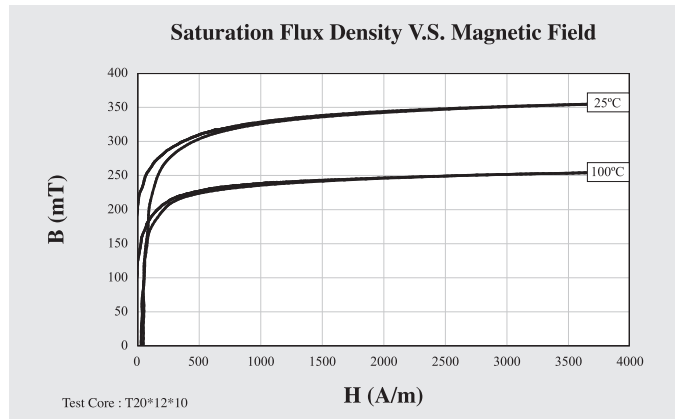
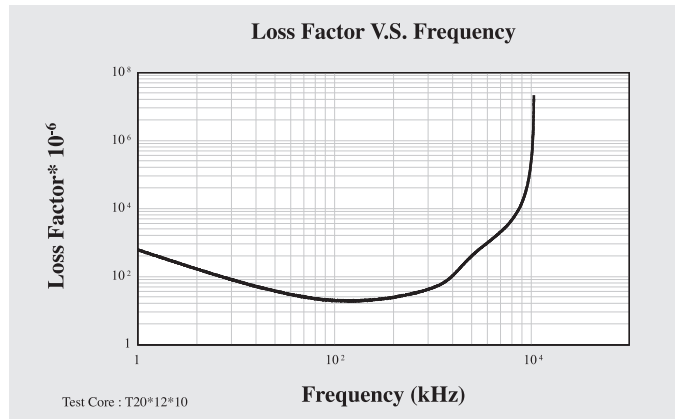

	Symbol	Unit	Measuring Conditions			EMI-Suppression Material
			Freq.	Flux den.	Temp.	K08
Initial Permeability	μ_i		$\leq 10\text{kHz}$	0.25mT	25°C	800 \pm 25%
Saturation Flux Density	Bms	mT	1kHz	H = 1200A/m	25°C	350
Remanence	Brms	mT	1kHz	H = 1200A/m	25°C	185
Coercivity	Hc	A/m	1kHz	H = 1200A/m	25°C	29
Relative Loss Factor	$\tan\delta/\mu_i$	10 ⁻⁶	100kHz	< 0.25mT	25°C	16
Temperature Factor of Permeability	α_F	10 ⁻⁶ /°C	10kHz	< 0.25 mT	20 ~ 60°C	6
Curie Temperature	Tc	°C				160
Resistivity	ρ	Ωm				> 10 ⁶
Density	d	g/cm ³				5.10

Note: Material characteristics are typical for a toroid core.
 Product specification will differ from these data due to the influence of geometry and size.

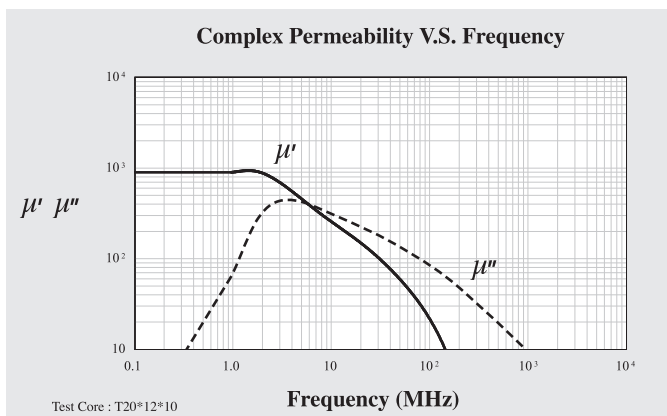
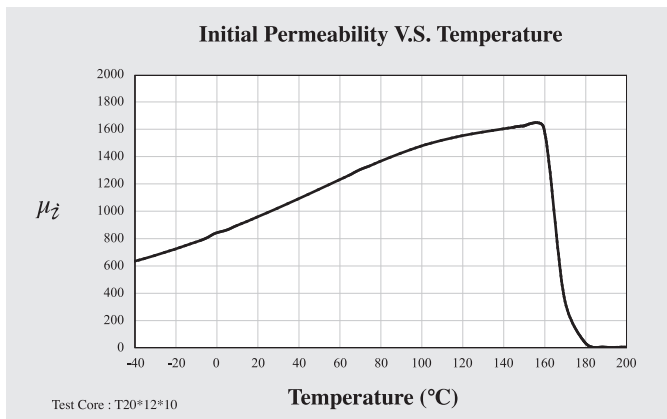
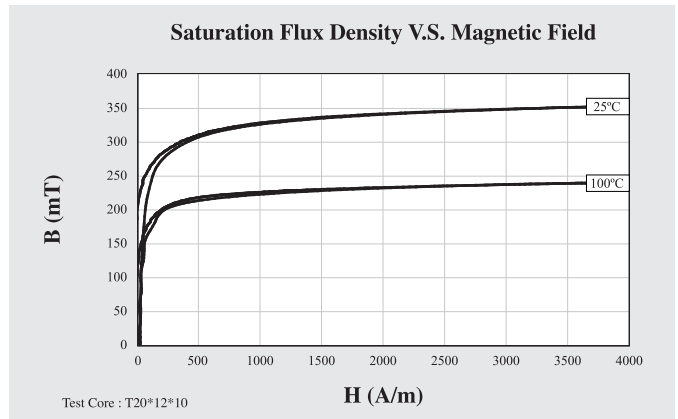
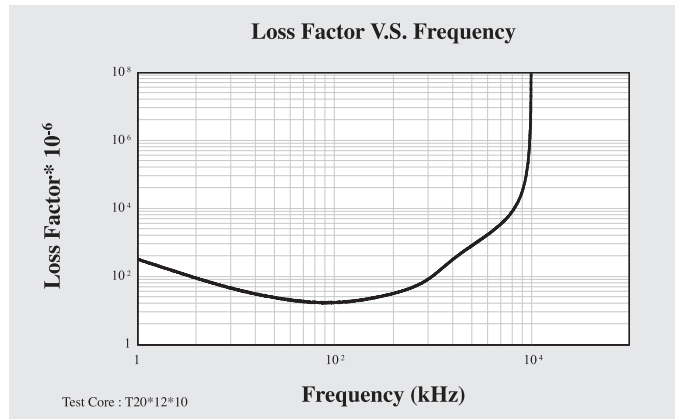

	Symbol	Unit	Measuring Conditions			EMI-Suppression Material
			Freq.	Flux den.	Temp.	K10
Initial Permeability	μ_i		$\leq 10\text{kHz}$	0.25mT	25°C	1000 \pm 25%
Saturation Flux Density	Bms	mT	1kHz	H = 1200A/m	25°C	355
Remanence	Brms	mT	1kHz	H = 1200A/m	25°C	250
Coercivity	Hc	A/m	1kHz	H = 1200A/m	25°C	17
Relative Loss Factor	$\tan\delta/\mu_i$	10^{-6}	100kHz	< 0.25mT	25°C	11
Temperature Factor of Permeability	α_F	$10^{-6}/^\circ\text{C}$	10kHz	< 0.25 mT	20 ~ 60°C	8
Curie Temperature	Tc	°C				160
Resistivity	ρ	Ωm				> 10^6
Density	d	g/cm^3				5.10

Note: Material characteristics are typical for a toroid core.
 Product specification will differ from these data due to the influence of geometry and size.

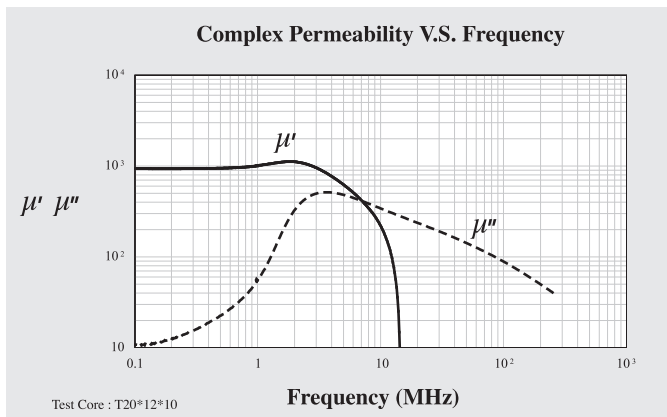
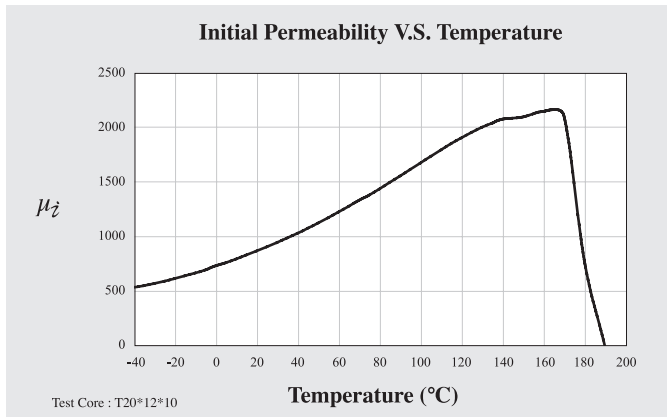
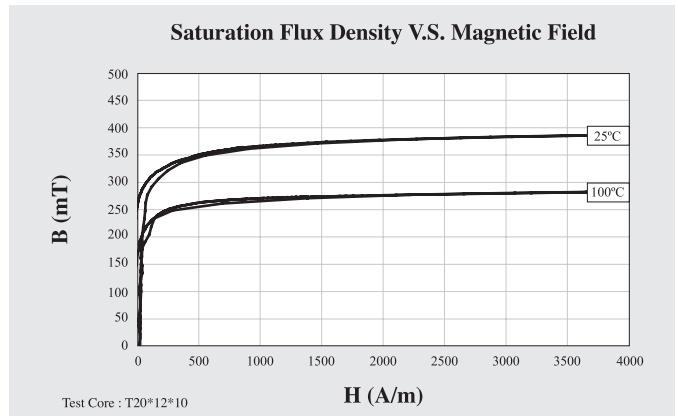
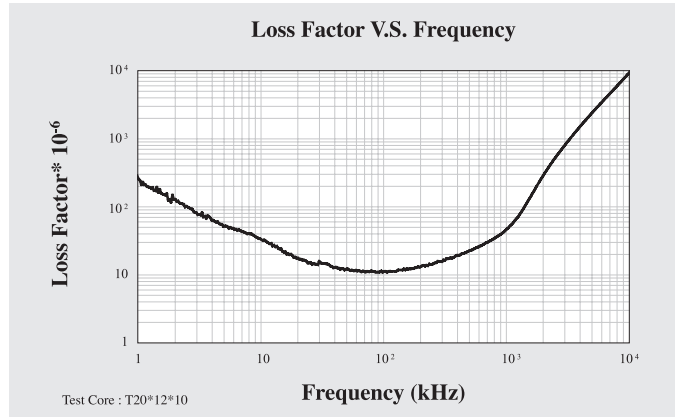

	Symbol	Unit	Measuring Conditions			EMI-Suppression Material
			Freq.	Flux den.	Temp.	K15
Initial Permeability	μ_i		$\leq 10\text{kHz}$	0.25mT	25°C	1500 \pm 25%
Saturation Flux Density	Bms	mT	1kHz	H = 1200A/m	25°C	330
Remanence	Brms	mT	1kHz	H = 1200A/m	25°C	200
Coercivity	Hc	A/m	1kHz	H = 1200A/m	25°C	11
Relative Loss Factor	$\tan\delta/\mu_i$	10 ⁻⁶	100kHz	< 0.25mT	25°C	11
Temperature Factor of Permeability	α_F	10 ⁻⁶ /°C	10kHz	< 0.25 mT	20 ~ 60°C	6
Curie Temperature	Tc	°C				130
Resistivity	ρ	Ωm				> 10 ⁶
Density	d	g/cm ³				5.10

Note: Material characteristics are typical for a toroid core.
 Product specification will differ from these data due to the influence of geometry and size.

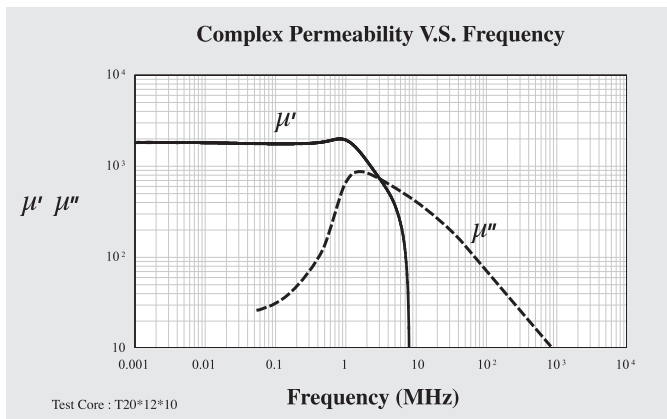
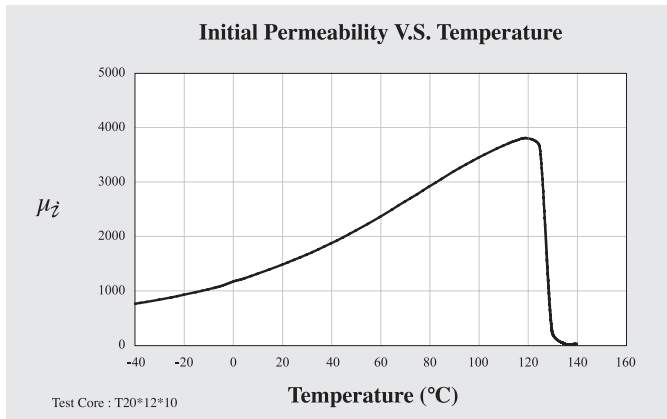
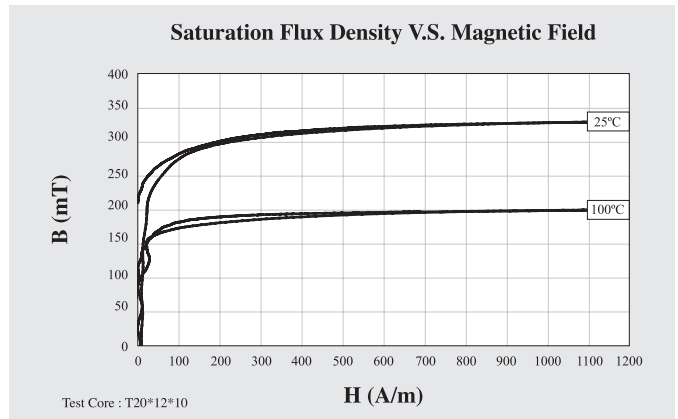
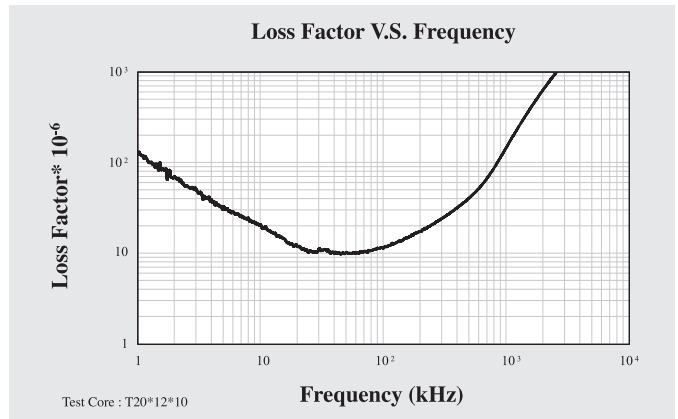

	Symbol	Unit	Measuring Conditions			EMI-Suppression Material
			Freq.	Flux den.	Temp.	K20
Initial Permeability	μ_i		$\leq 10\text{kHz}$	0.25mT	25°C	2000 \pm 25%
Saturation Flux Density	Bms	mT	1kHz	H = 1200A/m	25°C	300
Remanence	Brms	mT	1kHz	H = 1200A/m	25°C	150
Coercivity	Hc	A/m	1kHz	H = 1200A/m	25°C	10
Relative Loss Factor	$\tan\delta/\mu_i$	10^{-6}	100kHz	< 0.25mT	25°C	11
Temperature Factor of Permeability	α_F	$10^{-6}/^\circ\text{C}$	10kHz	< 0.25 mT	20 ~ 60°C	3
Curie Temperature	Tc	°C				100
Resistivity	ρ	Ωm				> 10^6
Density	d	g/cm^3				5.10

Note: Material characteristics are typical for a toroid core.
 Product specification will differ from these data due to the influence of geometry and size.

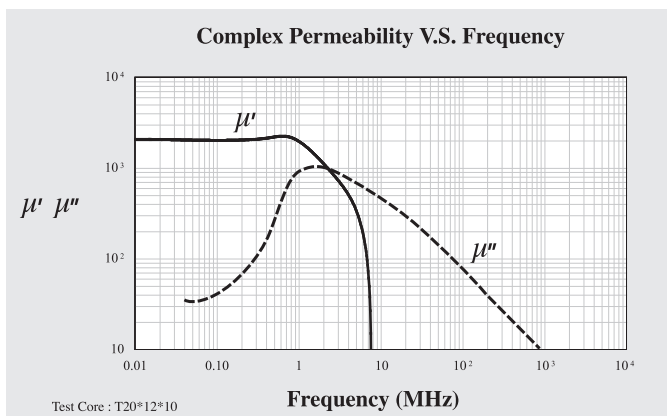
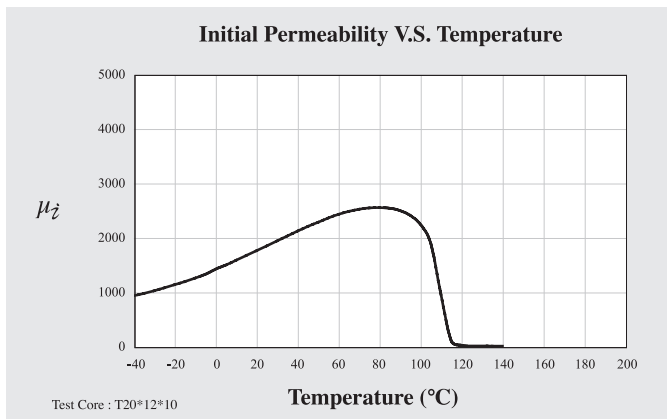
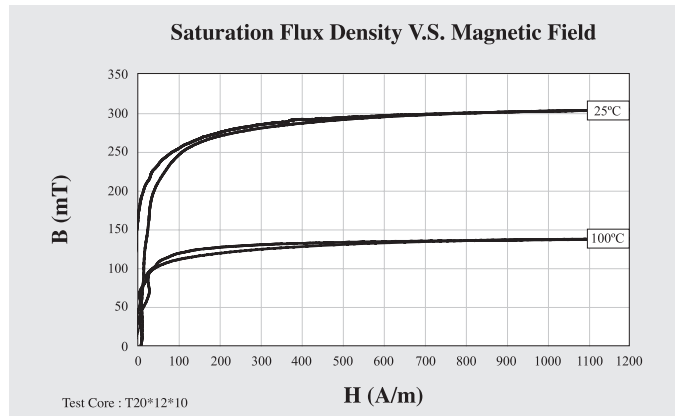
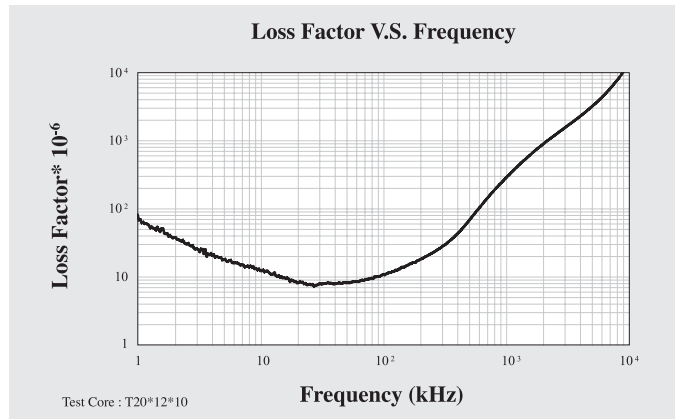

	Symbol	Unit	Measuring Conditions			Low Loss Material
			Freq.	Flux den.	Temp.	K081
Initial Permeability	μ_i		$\leq 10\text{kHz}$	0.25mT	25°C	800 \pm 25%
Power Loss	Pv	KW/m ³	50kHz	150mT	25°C	400
					100°C	300
					120°C	295
Saturation Flux Density	Bms	mT	1kHz	H = 1200A/m	25°C	410
Remanence	Brms	mT	1kHz	H = 1200A/m	25°C	272
Coercivity	Hc	A/m	1kHz	H = 1200A/m	25°C	27
Curie Temperature	Tc	°C				190
Resistivity	ρ	Ωm				> 10 ⁶
Density	d	g/cm ³				5.10

Note: Material characteristics are typical for a toroid core.
 Product specification will differ from these data due to the influence of geometry and size.

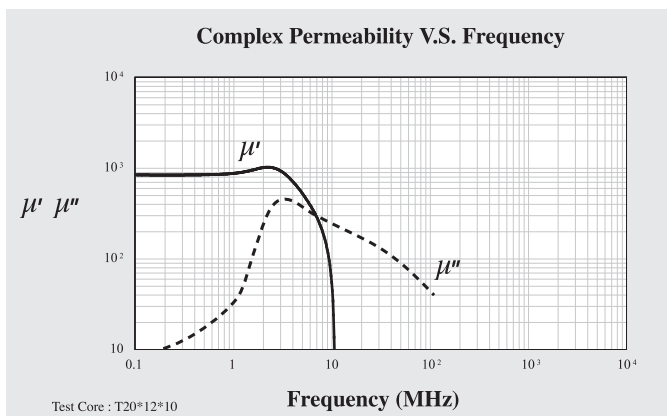
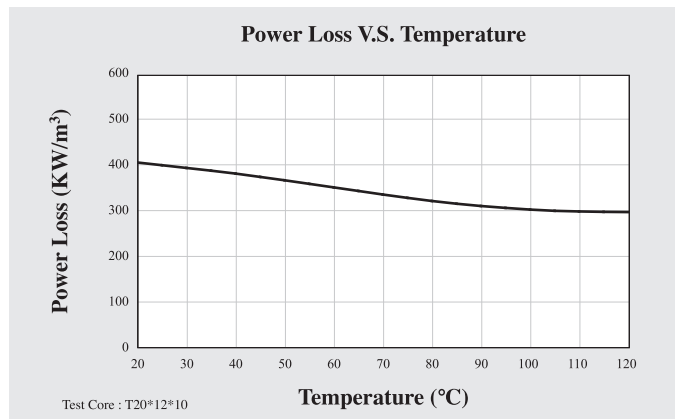
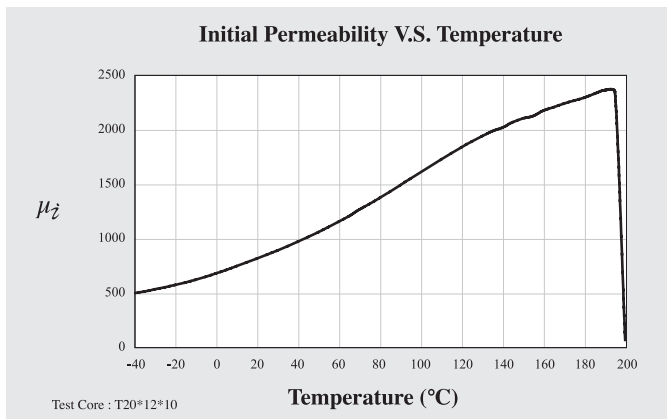
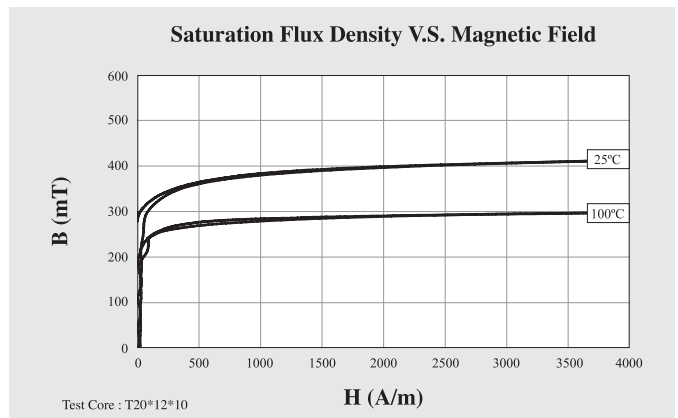
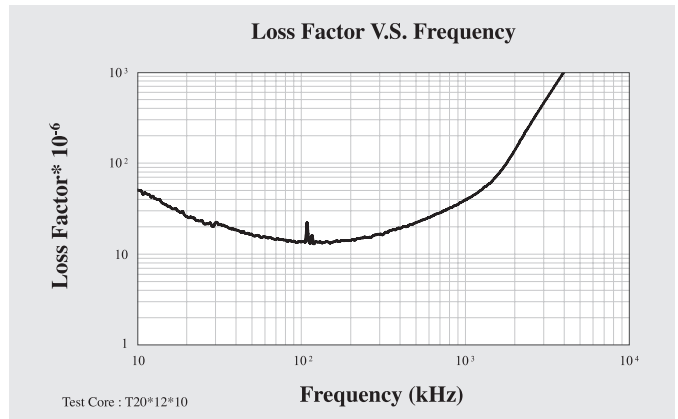

	Symbol	Unit	Measuring Conditions			Low Loss Material
			Freq.	Flux den.	Temp.	K12
Initial Permeability	μ_i		$\leq 10\text{kHz}$	0.25mT	25°C	1200 \pm 25%
Power Loss	Pv	KW/m ³	50kHz	150mT	25°C	315
					100°C	270
					120°C	287
Saturation Flux Density	Bms	mT	1kHz	H = 1200A/m	25°C	355
Remanence	Brms	mT	1kHz	H = 1200A/m	25°C	250
Coercivity	Hc	A/m	1kHz	H = 1200A/m	25°C	17
Curie Temperature	Tc	°C				160
Resistivity	ρ	Ωm				$> 10^6$
Density	d	g/cm ³				5.10

Note: Material characteristics are typical for a toroid core.
 Product specification will differ from these data due to the influence of geometry and size.

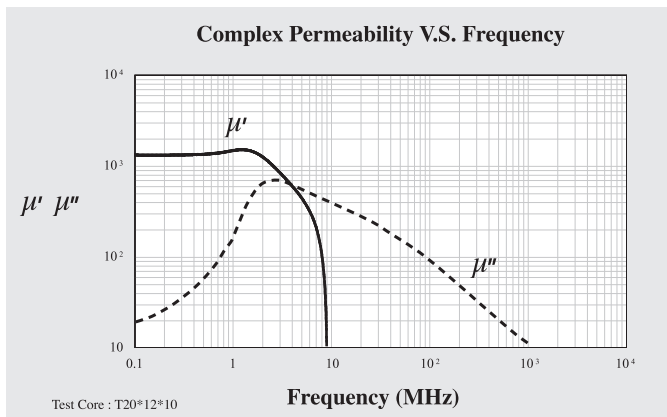
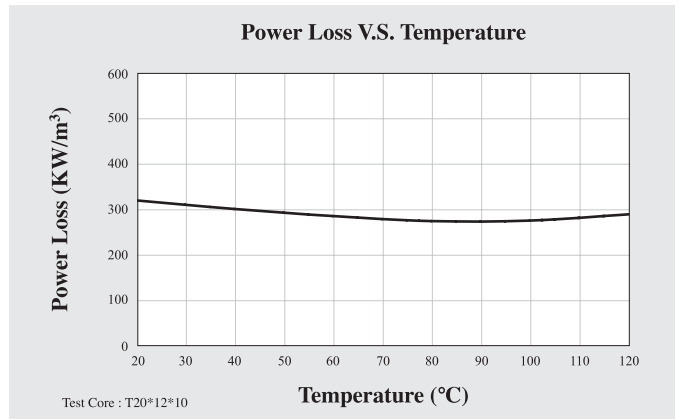
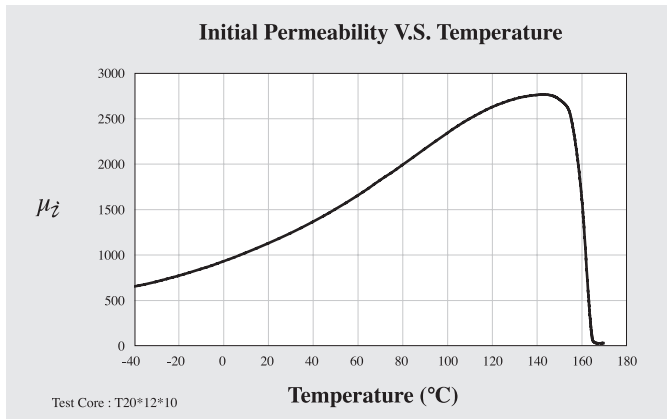
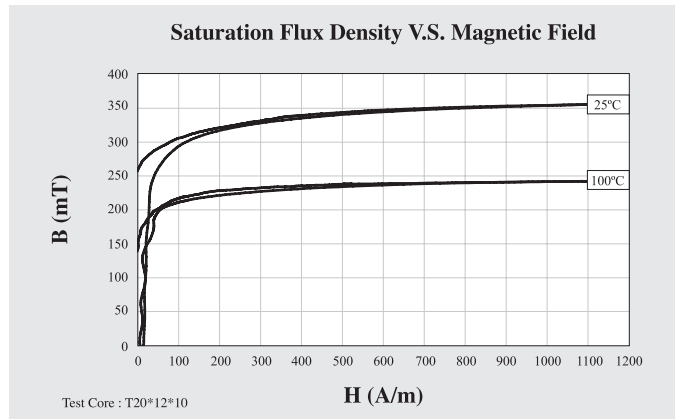
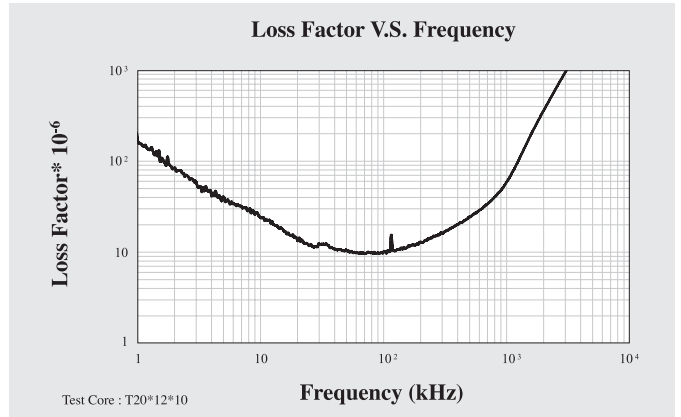

	Symbol	Unit	Measuring Conditions			High Bs Material
			Freq.	Flux den.	Temp.	B25
Initial Permeability	μ_i		$\leq 10\text{kHz}$	0.25mT	25°C	250 ± 25%
Saturation Flux Density	Bms	mT	1kHz	H = 4000A/m	25°C	450
Remanence	Brms	mT	1kHz	H = 4000A/m	25°C	270
Coercivity	Hc	A/m	1kHz	H = 4000A/m	25°C	80
Relative Loss Factor	$\tan\delta/\mu_i$	10 ⁻⁶	100kHz	< 0.25mT	25°C	60
Temperature Factor of Permeability	α_F	10 ⁻⁶ /°C	10kHz	< 0.25 mT	20 ~ 60°C	12
Curie Temperature	Tc	°C				250
Resistivity	ρ	Ωm				> 10 ⁶
Density	d	g/cm ³				5.20

Note: Material characteristics are typical for a toroid core.
Product specification will differ from these data due to the influence of geometry and size.

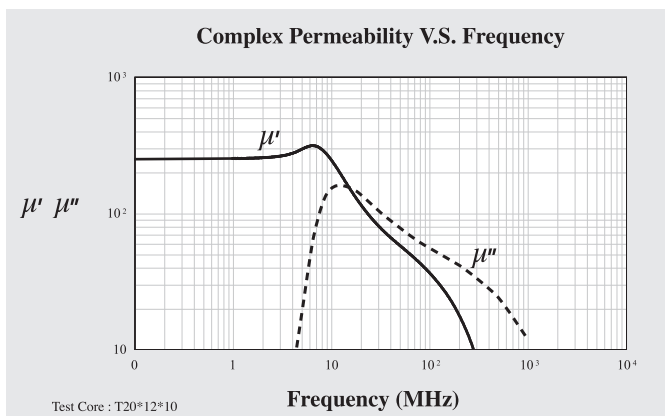
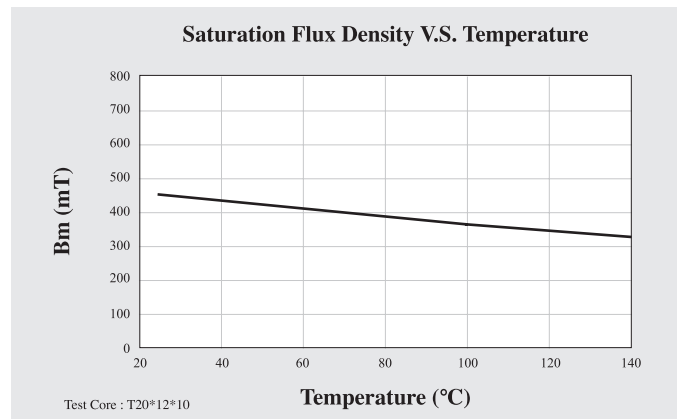
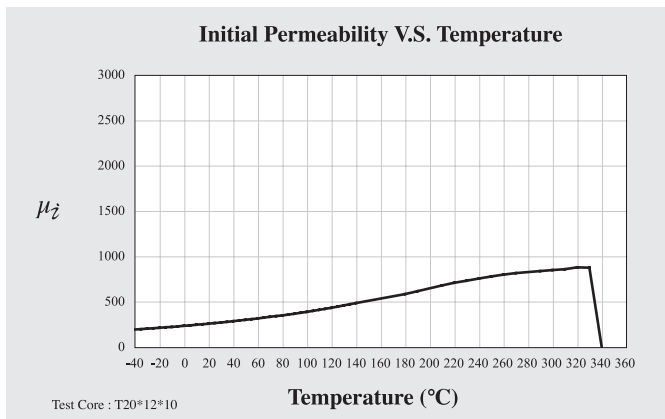
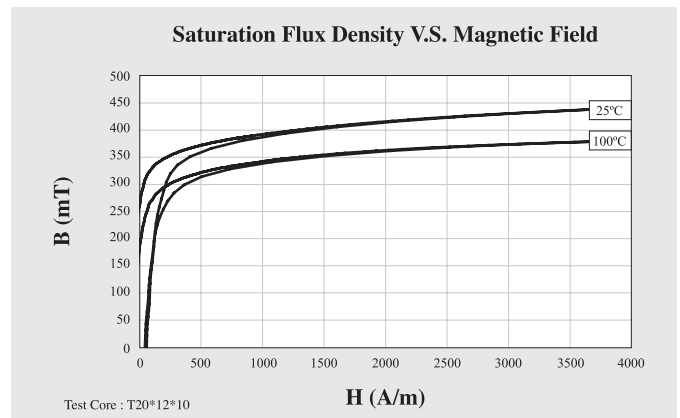
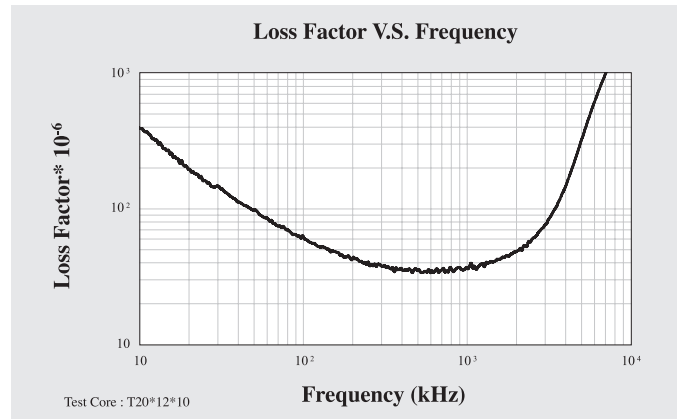

	Symbol	Unit	Measuring Conditions			High Bs Material
			Freq.	Flux den.	Temp.	B30
Initial Permeability	μ_i		$\leq 10\text{kHz}$	0.25mT	25°C	300 \pm 25%
Saturation Flux Density	Bms	mT	1kHz	H = 4000A/m	25°C	470
Remanence	Brms	mT	1kHz	H = 4000A/m	25°C	340
Coercivity	Hc	A/m	1kHz	H = 4000A/m	25°C	70
Relative Loss Factor	$\tan\delta/\mu_i$	10 ⁻⁶	100kHz	< 0.25mT	25°C	35
Temperature Factor of Permeability	α_F	10 ⁻⁶ /°C	10kHz	< 0.25 mT	20 ~ 60°C	16
Curie Temperature	Tc	°C				300
Resistivity	ρ	Ωm				> 10 ⁶
Density	d	g/cm ³				5.20

Note: Material characteristics are typical for a toroid core.
 Product specification will differ from these data due to the influence of geometry and size.

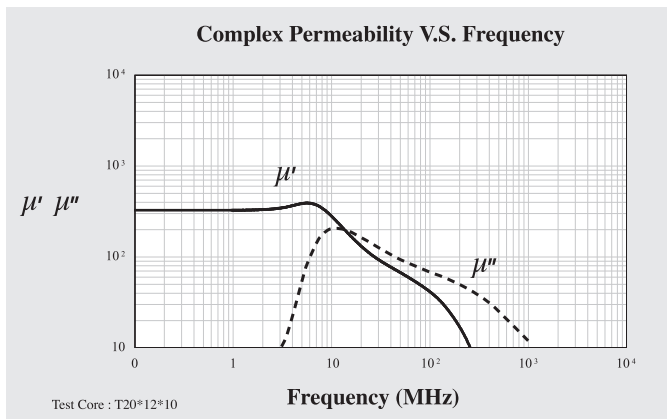
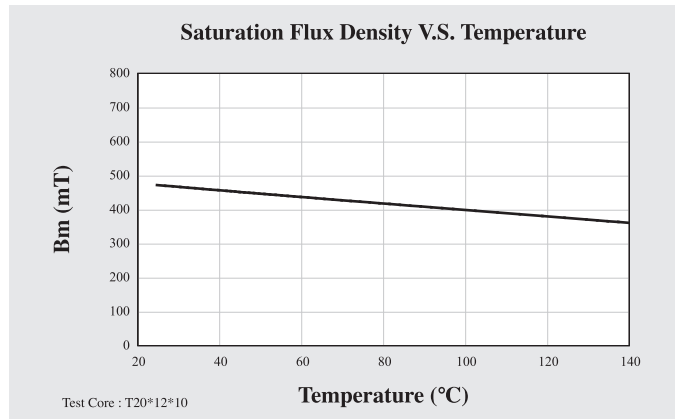
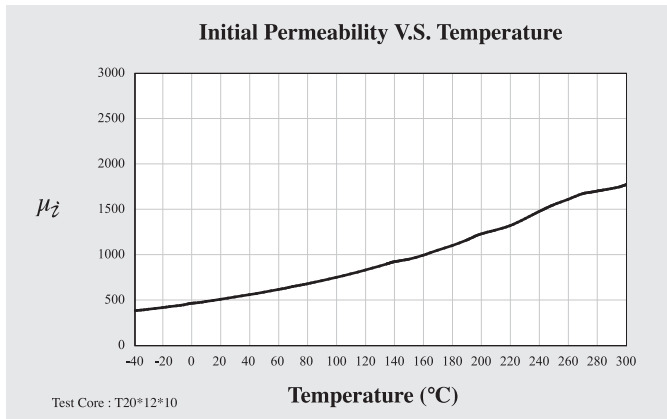
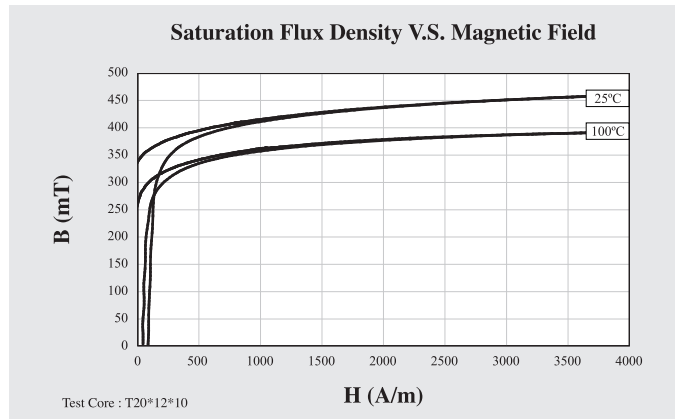
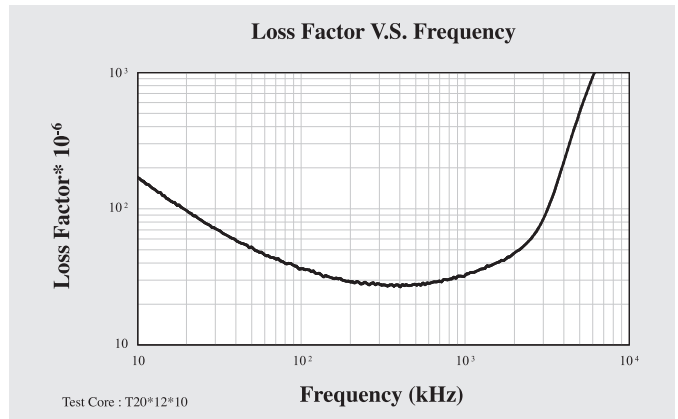

	Symbol	Unit	Measuring Conditions			High Bs Material
			Freq.	Flux den.	Temp.	B40
Initial Permeability	μ_i		$\leq 10\text{kHz}$	0.25mT	25°C	400 ± 25%
Saturation Flux Density	B _{ms}	mT	1kHz	H = 4000A/m	25°C	430
Remanence	B _{rms}	mT	1kHz	H = 4000A/m	25°C	270
Coercivity	H _c	A/m	1kHz	H = 4000A/m	25°C	45
Relative Loss Factor	$\tan\delta/\mu_i$	10 ⁻⁶	100kHz	< 0.25mT	25°C	21
Temperature Factor of Permeability	α_F	10 ⁻⁶ /°C	10kHz	< 0.25 mT	20 ~ 60°C	10
Curie Temperature	T _c	°C				240
Resistivity	ρ	Ωm				> 10 ⁶
Density	d	g/cm ³				5.20

Note: Material characteristics are typical for a toroid core.
 Product specification will differ from these data due to the influence of geometry and size.

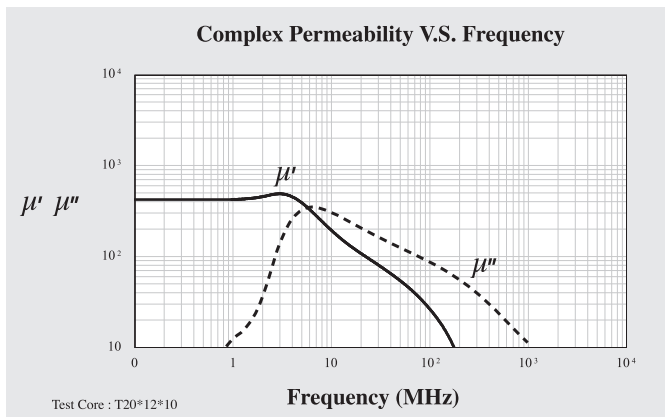
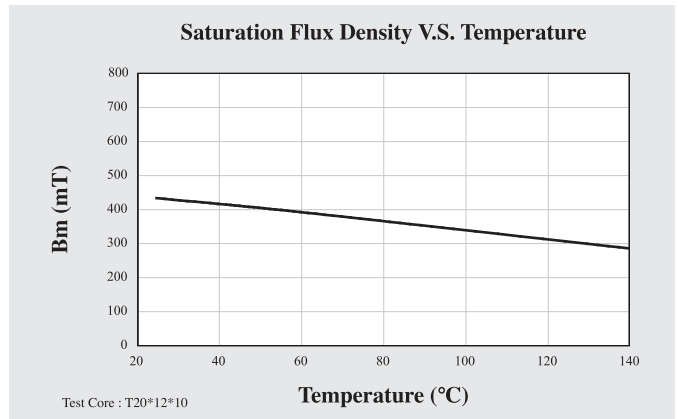
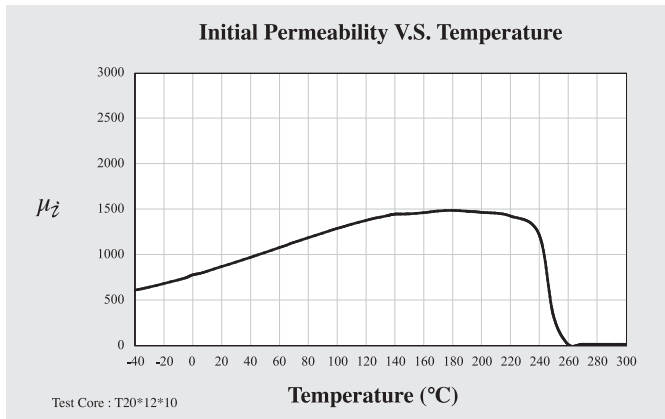
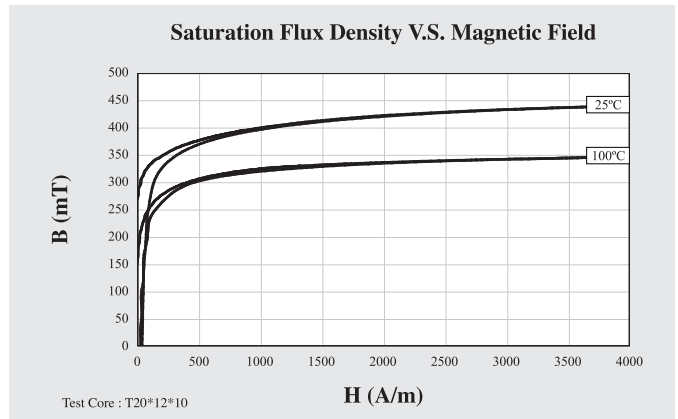
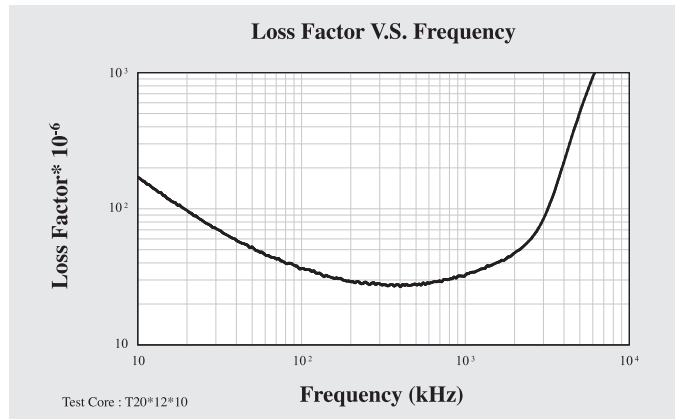

	Symbol	Unit	Measuring Conditions			High Bs Material
			Freq.	Flux den.	Temp.	B45
Initial Permeability	μ_i		$\leq 10\text{kHz}$	0.25mT	25°C	450 ± 25%
Saturation Flux Density	Bms	mT	1kHz	H = 4000A/m	25°C	450
Remanence	Brms	mT	1kHz	H = 4000A/m	25°C	320
Coercivity	Hc	A/m	1kHz	H = 4000A/m	25°C	40
Relative Loss Factor	$\tan\delta/\mu_i$	10 ⁻⁶	100kHz	< 0.25mT	25°C	30
Temperature Factor of Permeability	α_F	10 ⁻⁶ /°C	10kHz	< 0.25 mT	20 ~ 60°C	15
Curie Temperature	Tc	°C				240
Resistivity	ρ	Ωm				> 10 ⁶
Density	d	g/cm ³				5.20

Note: Material characteristics are typical for a toroid core.
 Product specification will differ from these data due to the influence of geometry and size.

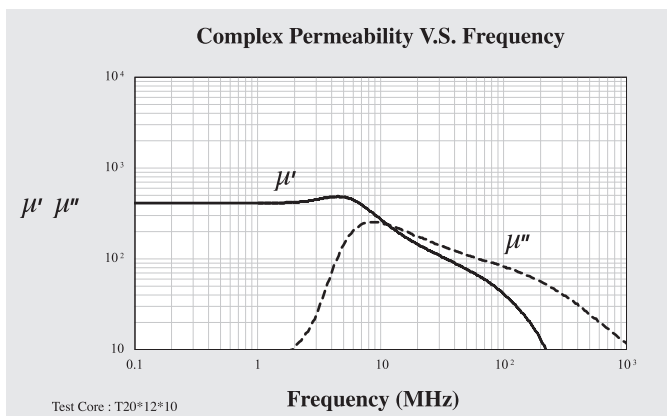
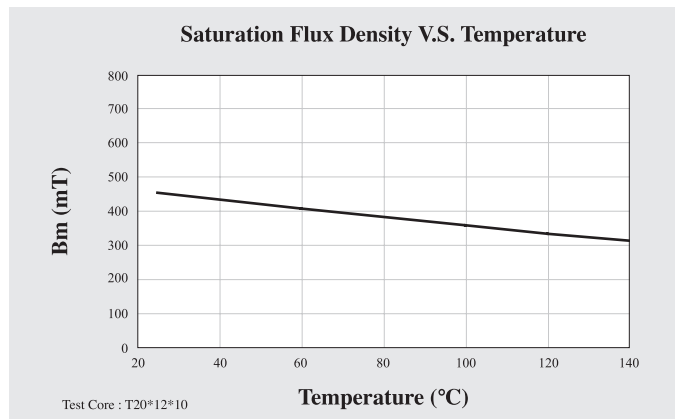
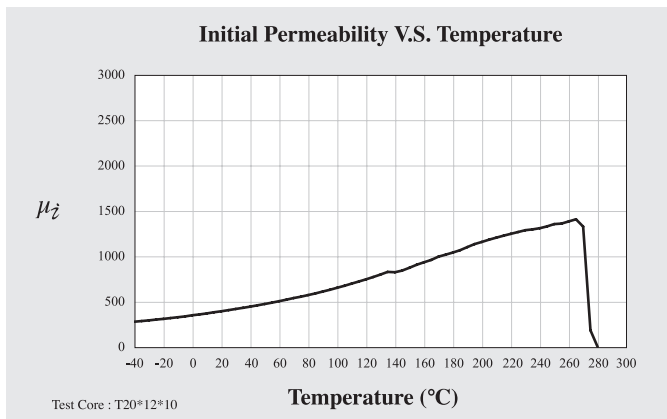
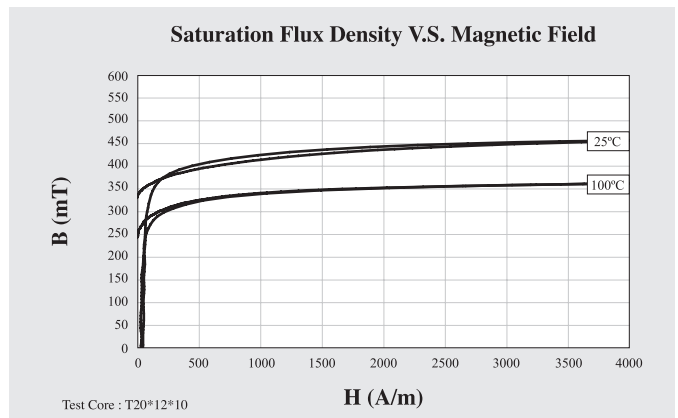
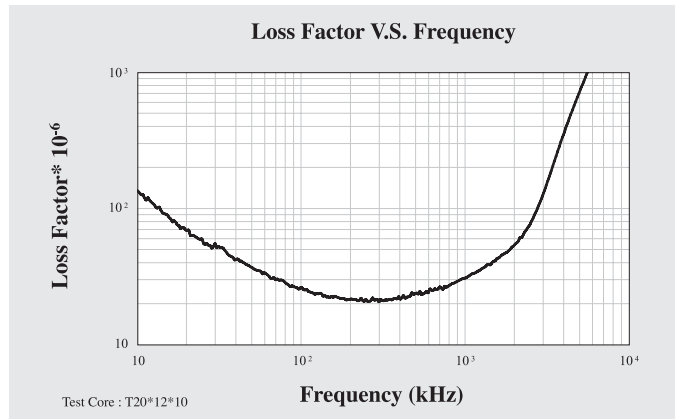

	Symbol	Unit	Measuring Conditions			High Bs Material
			Freq.	Flux den.	Temp.	B60
Initial Permeability	μ_i		$\leq 10\text{kHz}$	0.25mT	25°C	600 ± 25%
Saturation Flux Density	Bms	mT	1kHz	H = 4000A/m	25°C	430
Remanence	Brms	mT	1kHz	H = 4000A/m	25°C	310
Coercivity	Hc	A/m	1kHz	H = 4000A/m	25°C	36
Relative Loss Factor	$\tan\delta/\mu_i$	10 ⁻⁶	100kHz	< 0.25mT	25°C	18
Temperature Factor of Permeability	α_F	10 ⁻⁶ /°C	10kHz	< 0.25 mT	20 ~ 60°C	12
Curie Temperature	Tc	°C				210
Resistivity	ρ	Ωm				> 10 ⁶
Density	d	g/cm ³				5.20

Note: Material characteristics are typical for a toroid core.
Product specification will differ from these data due to the influence of geometry and size.

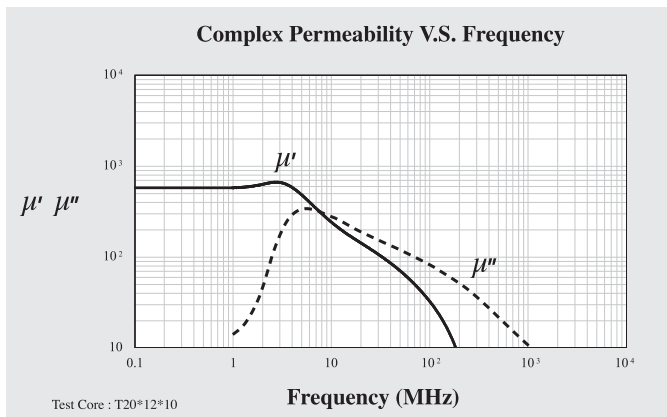
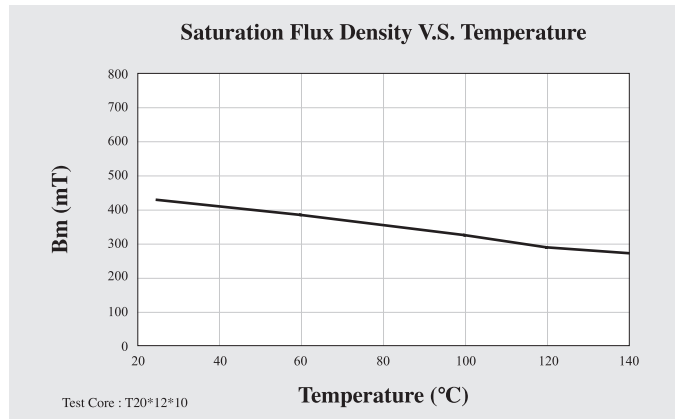
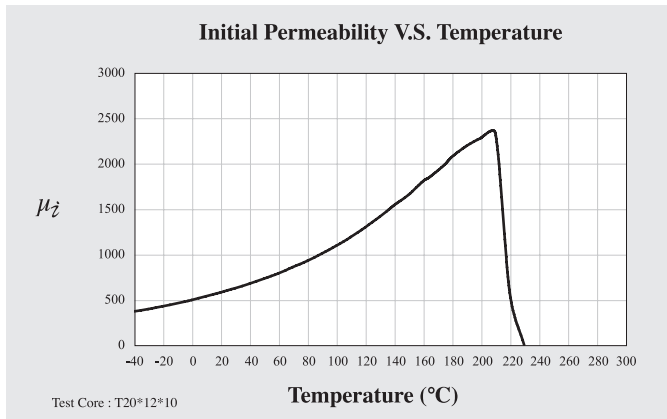
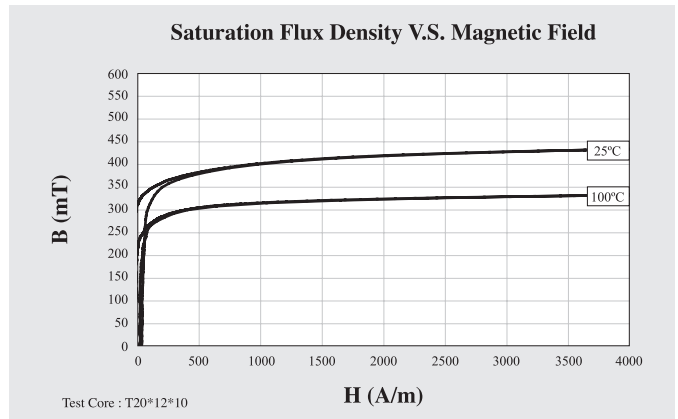
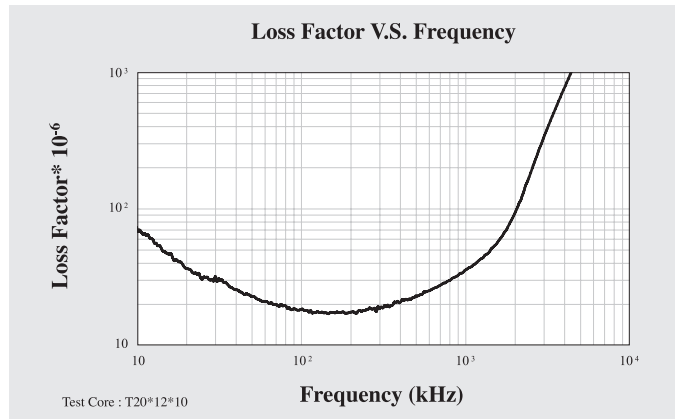

	Symbol	Unit	Measuring Conditions			High Bs Material
			Freq.	Flux den.	Temp.	B90
Initial Permeability	μ_i		$\leq 10\text{kHz}$	0.25mT	25°C	900 \pm 25%
Saturation Flux Density	Bms	mT	1kHz	H = 4000A/m	25°C	390
Remanence	Brms	mT	1kHz	H = 4000A/m	25°C	270
Coercivity	Hc	A/m	1kHz	H = 4000A/m	25°C	30
Relative Loss Factor	$\tan\delta/\mu_i$	10 ⁻⁶	100kHz	< 0.25mT	25°C	13
Temperature Factor of Permeability	α_F	10 ⁻⁶ /°C	10kHz	< 0.25 mT	20 ~ 60°C	8
Curie Temperature	Tc	°C				180
Resistivity	ρ	Ωm				> 10 ⁶
Density	d	g/cm ³				5.20

Note: Material characteristics are typical for a toroid core.
 Product specification will differ from these data due to the influence of geometry and size.

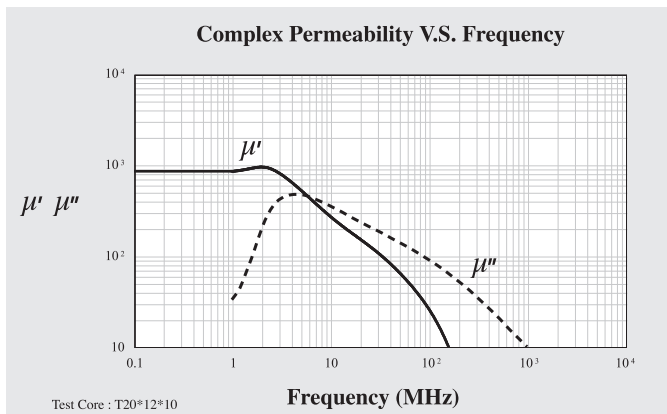
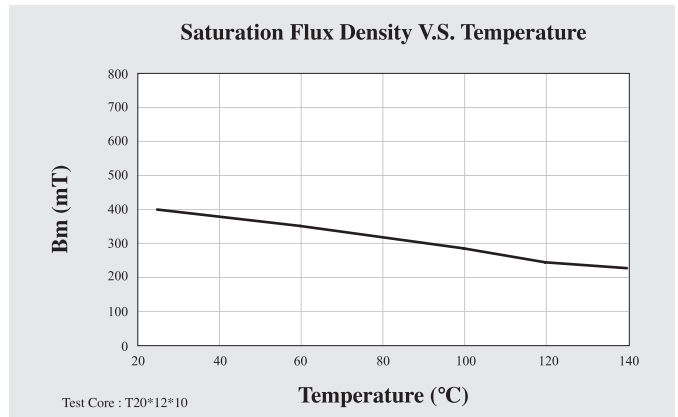
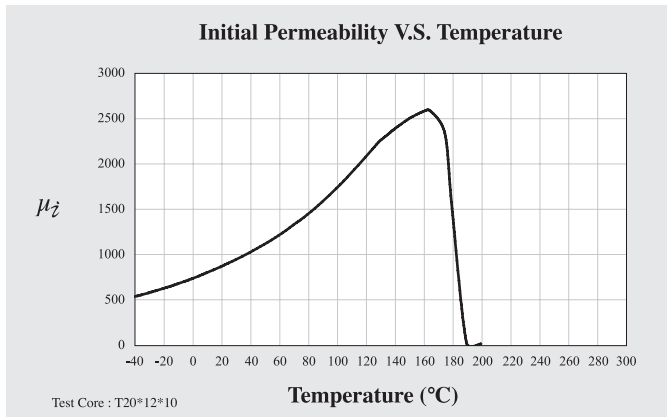
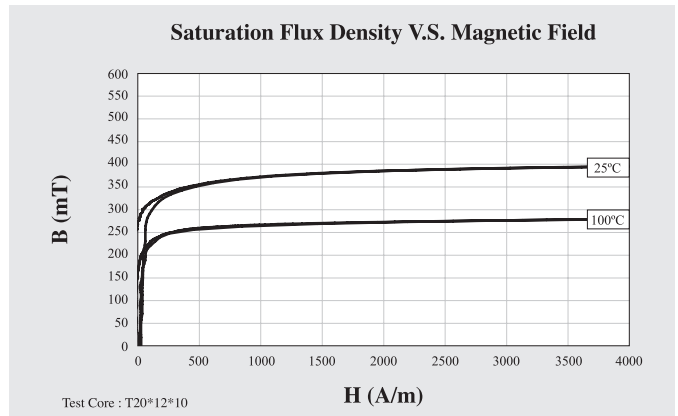
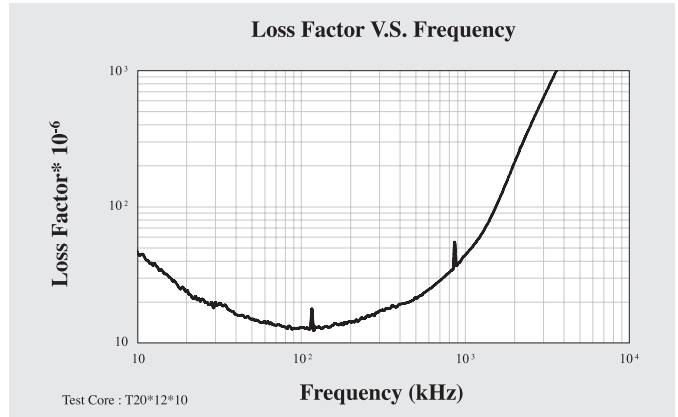

	Symbol	Unit	Measuring Conditions			Rod Core Material
			Freq.	Flux den.	Temp.	H2
Initial Permeability	μ_z		$\leq 10\text{kHz}$	0.25mT	25°C	50 \pm 25%
Relative Loss Factor	$\tan\delta/\mu_z$	10 ⁻⁶	1kHz		25°C	285
Saturation Flux Density	Bms	mT	1kHz	H = 4000A/m	25°C	400
					100°C	350
Remanence	Brms	mT	1kHz	H = 4000A/m	25°C	281
					100°C	238
Coercivity	Hc	A/m	1kHz	H = 4000A/m	25°C	168
					100°C	121
Temperature Factor of Permeability	αF	10 ⁻⁶ /°C			20 ~ 80°C	100
Curie Temperature	Tc	°C				300
Resistivity	ρ	Ωm				10 ⁶
Density	d	g/cm ³				5.10

Note: Material characteristics are typical for a toroid core.
 Product specification will differ from these data due to the influence of geometry and size.

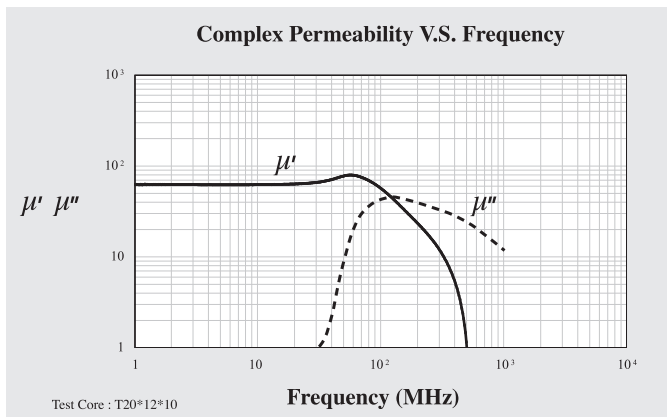
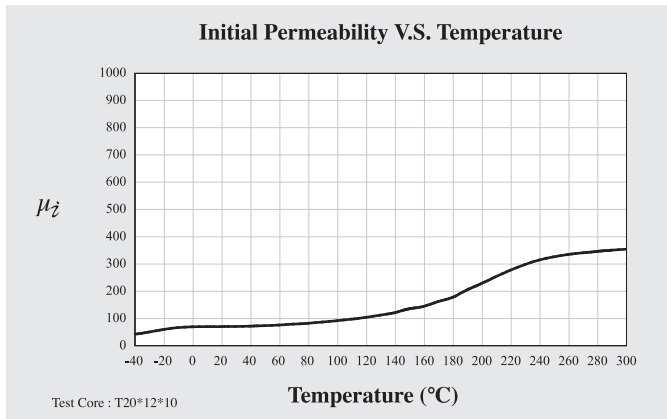
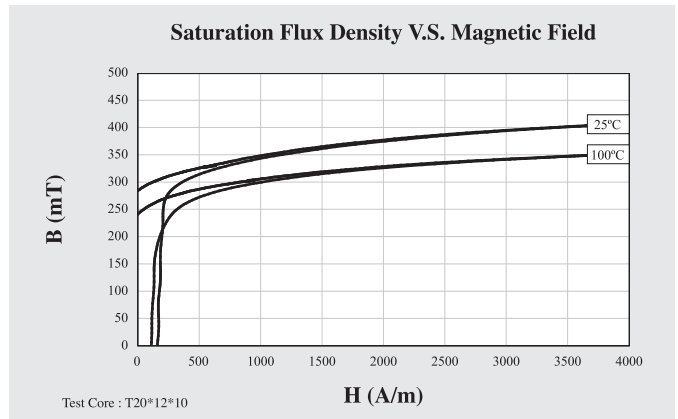
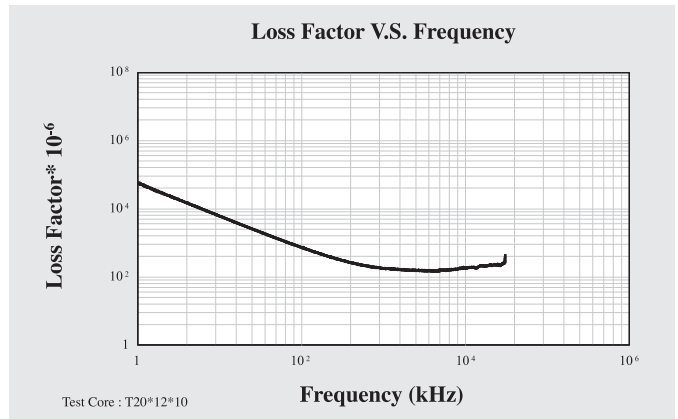

	Symbol	Unit	Measuring Conditions			Rod Core Material
			Freq.	Flux den.	Temp.	H3
Initial Permeability	μ_i		$\leq 10\text{kHz}$	0.25mT	25°C	100 \pm 25%
Relative Loss Factor	$\tan\delta/\mu_i$	10 ⁻⁶	1kHz		25°C	88
Saturation Flux Density	B _{ms}	mT	1kHz	H = 4000A/m	25°C	330
					100°C	275
Remanence	Br _{ms}	mT	1kHz	H = 4000A/m	25°C	234
					100°C	110
Coercivity	H _c	A/m	1kHz	H = 4000A/m	25°C	87
					100°C	64
Temperature Factor of Permeability	α_F	10 ⁻⁶ /°C			20 ~ 80°C	80
Curie Temperature	T _c	°C				250
Resistivity	ρ	Ωm				10 ⁶
Density	d	g/cm ³				4.80

Note: Material characteristics are typical for a toroid core.
Product specification will differ from these data due to the influence of geometry and size.

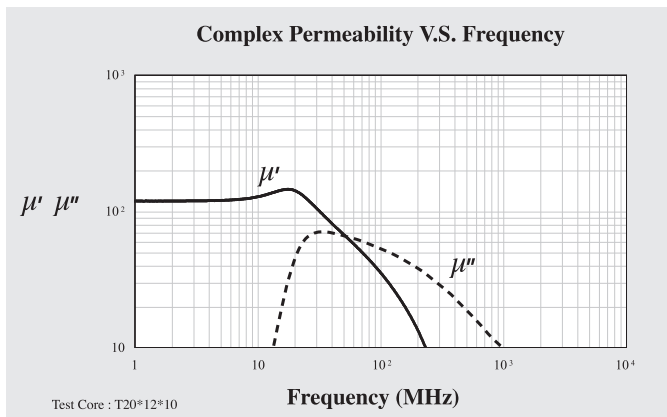
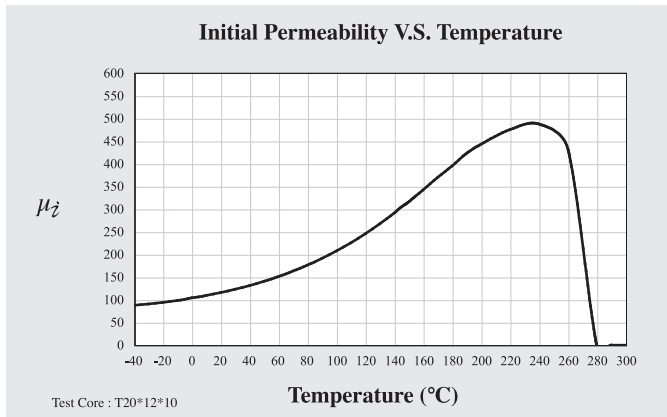
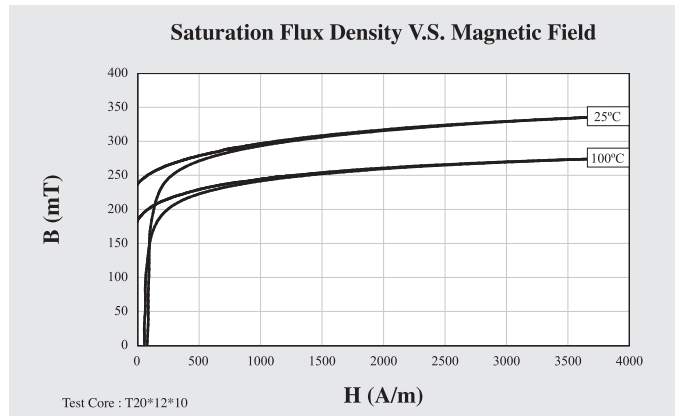
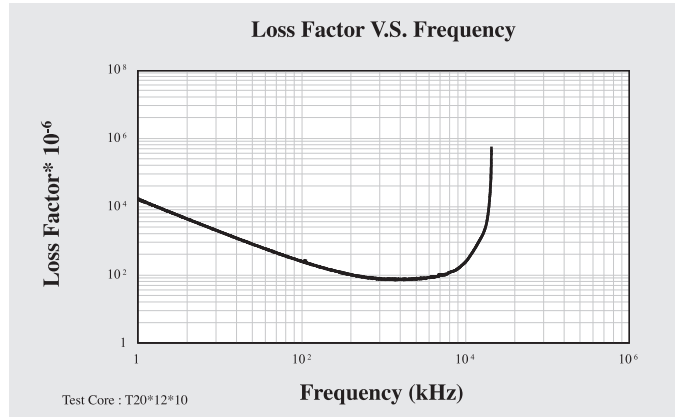

	Symbol	Unit	Measuring Conditions			Rod Core Material
			Freq.	Flux den.	Temp.	H3A
Initial Permeability	μ_z		$\leq 10\text{kHz}$	0.25mT	25°C	125 ± 25%
Relative Loss Factor	$\tan\delta/\mu_z$	10^{-6}	1kHz		25°C	390
Saturation Flux Density	Bms	mT	1kHz	H = 4000A/m	25°C	320
					100°C	262
Remanence	Brms	mT	1kHz	H = 4000A/m	25°C	219
					100°C	163
Coercivity	Hc	A/m	1kHz	H = 4000A/m	25°C	115
					100°C	83
Temperature Factor of Permeability	αF	$10^{-6}/^\circ\text{C}$			20 ~ 80°C	110
Curie Temperature	Tc	°C				230
Resistivity	ρ	Ωm				10^6
Density	d	g/cm^3				4.60

Note: Material characteristics are typical for a toroid core.
Product specification will differ from these data due to the influence of geometry and size.

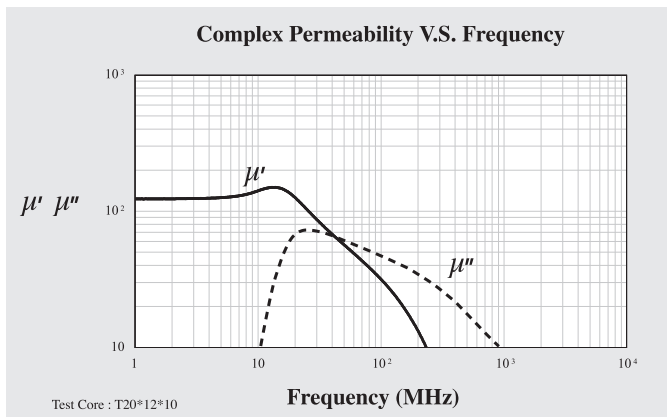
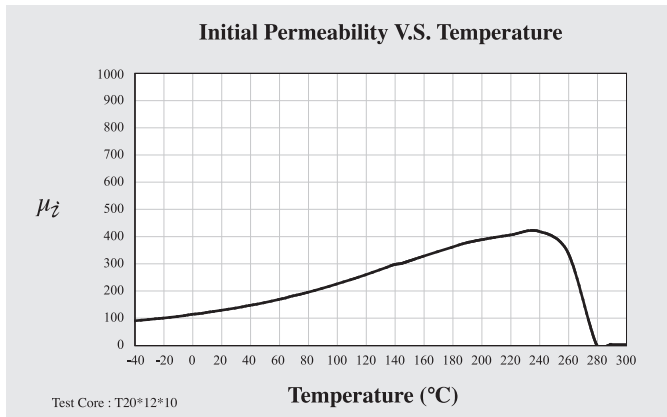
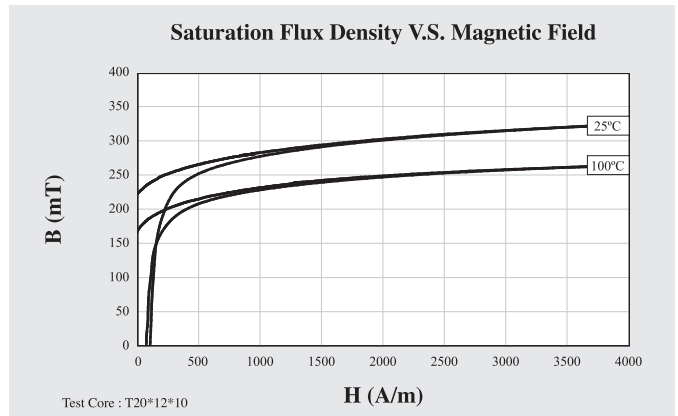
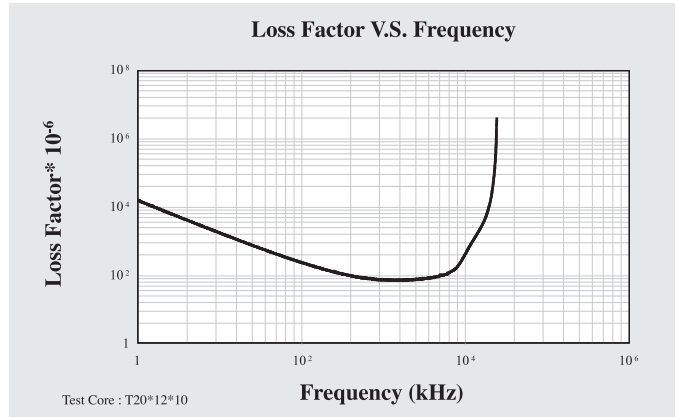

	Symbol	Unit	Measuring Conditions			Rod Core Material
			Freq.	Flux den.	Temp.	H3B
Initial Permeability	μ_z		$\leq 10\text{kHz}$	0.25mT	25°C	150 \pm 25%
Relative Loss Factor	$\tan\delta/\mu_z$	10^{-6}	1kHz		25°C	163
Saturation Flux Density	Bms	mT	1kHz	H = 4000A/m	25°C	330
					100°C	270
Remanence	Brms	mT	1kHz	H = 4000A/m	25°C	247
					100°C	186
Coercivity	Hc	A/m	1kHz	H = 4000A/m	25°C	91
					100°C	62
Temperature Factor of Permeability	αF	$10^{-6}/^\circ\text{C}$			20 ~ 80°C	60
Curie Temperature	Tc	°C				220
Resistivity	ρ	Ωm				10^6
Density	d	g/cm^3				4.80

Note: Material characteristics are typical for a toroid core.
 Product specification will differ from these data due to the influence of geometry and size.

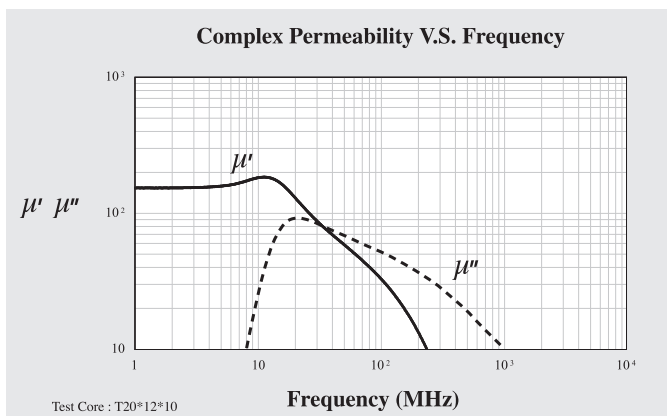
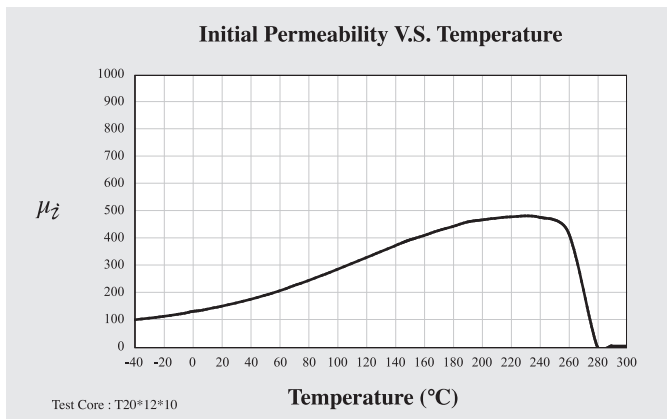
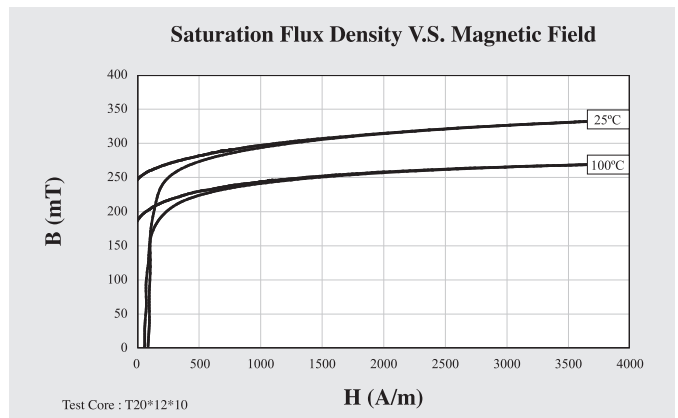
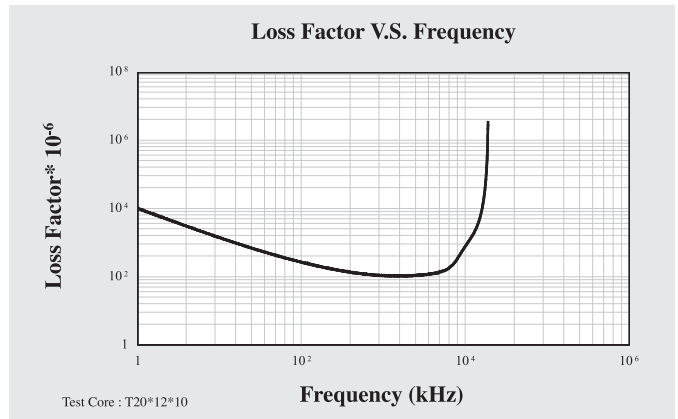

	Symbol	Unit	Measuring Conditions			Rod Core Material
			Freq.	Flux den.	Temp.	H4
Initial Permeability	μ_z		$\leq 10\text{kHz}$	0.25mT	25°C	300 \pm 25%
Relative Loss Factor	$\tan\delta/\mu_z$	10 ⁻⁶	1kHz		25°C	145
Saturation Flux Density	B _{ms}	mT	1kHz	H = 4000A/m	25°C	330
					100°C	240
Remanence	Br _{ms}	mT	1kHz	H = 4000A/m	25°C	222
					100°C	133
Coercivity	H _c	A/m	1kHz	H = 4000A/m	25°C	47
					100°C	30
Temperature Factor of Permeability	α_F	10 ⁻⁶ /°C			20 ~ 80°C	100
Curie Temperature	T _c	°C				160
Resistivity	ρ	Ωm				10 ⁶
Density	d	g/cm ³				4.80

Note: Material characteristics are typical for a toroid core.
 Product specification will differ from these data due to the influence of geometry and size.

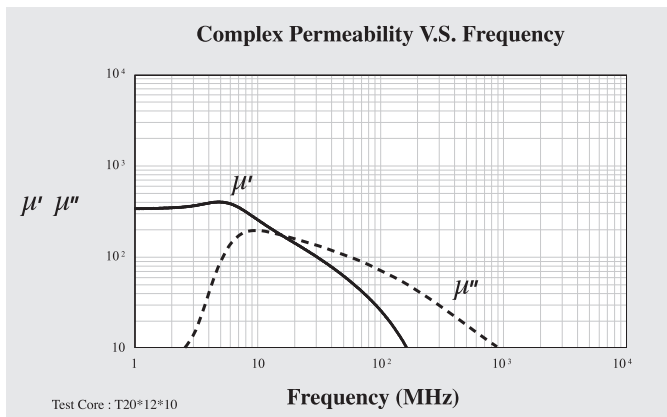
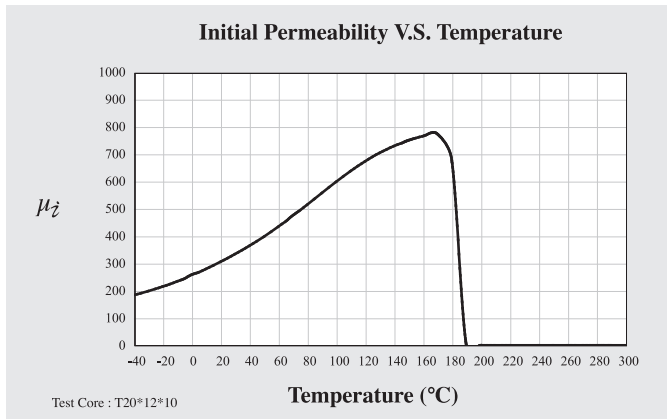
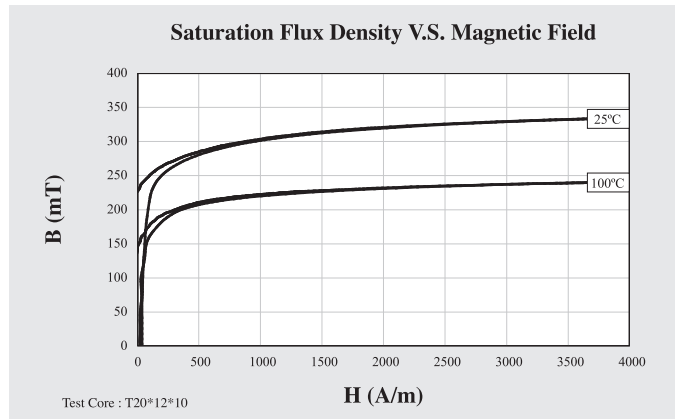
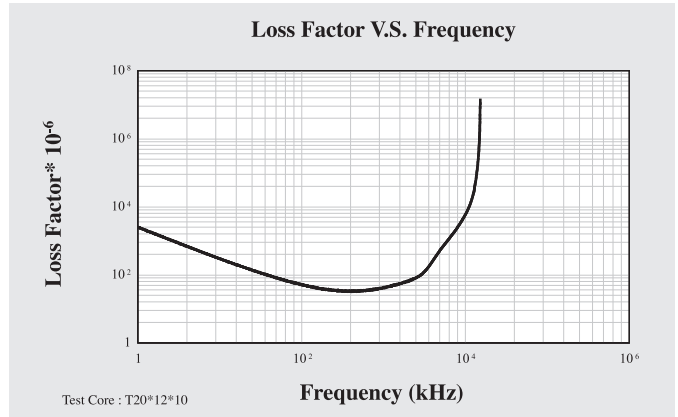

	Symbol	Unit	Measuring Conditions			Rod Core Material
			Freq.	Flux den.	Temp.	H5
Initial Permeability	μ_i		$\leq 10\text{kHz}$	0.25mT	25°C	250 ± 25%
Relative Loss Factor	$\tan\delta/\mu_i$	10 ⁻⁶	1kHz		25°C	50
Saturation Flux Density	B _{ms}	mT	1kHz	H = 4000A/m	25°C	410
					100°C	345
Remanence	Br _{ms}	mT	1kHz	H = 4000A/m	25°C	324
					100°C	243
Coercivity	H _c	A/m	1kHz	H = 4000A/m	25°C	68
					100°C	32
Temperature Factor of Permeability	α_F	10 ⁻⁶ /°C			20 ~ 80°C	40
Curie Temperature	T _c	°C				250
Resistivity	ρ	Ωm				10 ⁶
Density	d	g/cm ³				5.10

Note: Material characteristics are typical for a toroid core.
 Product specification will differ from these data due to the influence of geometry and size.

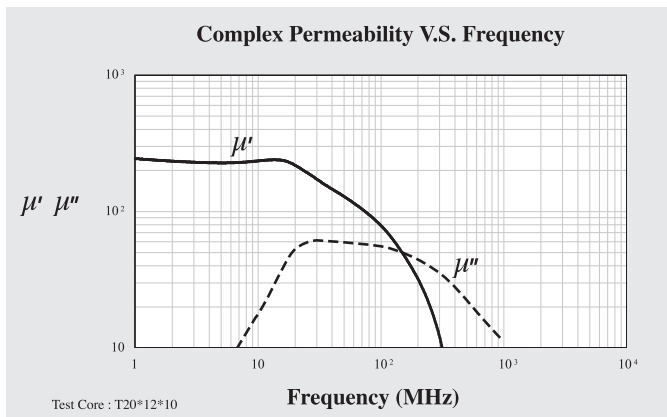
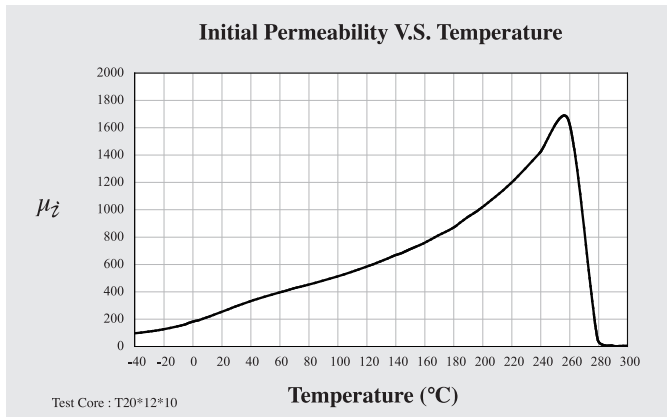
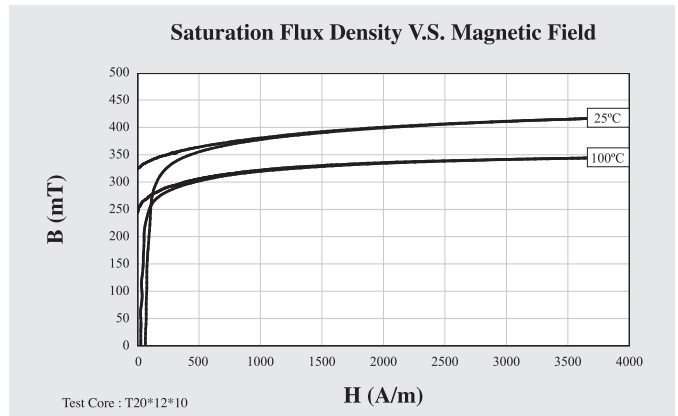
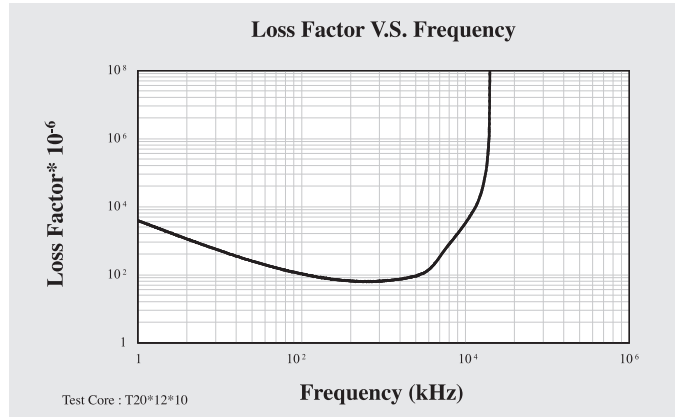

	Symbol	Unit	Measuring Conditions			Rod Core Material
			Freq.	Flux den.	Temp.	H5M
Initial Permeability	μ_z		$\leq 10\text{kHz}$	0.25mT	25°C	230 \pm 25%
Relative Loss Factor	$\tan\delta/\mu_z$	10^{-6}	1kHz		25°C	50
Saturation Flux Density	Bms	mT	1kHz	H = 4000A/m	25°C	430
					100°C	366
Remanence	Brms	mT	1kHz	H = 4000A/m	25°C	272
					100°C	189
Coercivity	Hc	A/m	1kHz	H = 4000A/m	25°C	92
					100°C	79
Temperature Factor of Permeability	αF	$10^{-6}/^\circ\text{C}$			20 ~ 80°C	30
Curie Temperature	Tc	°C				280
Resistivity	ρ	Ωm				10^6
Density	d	g/cm^3				5.10

Note: Material characteristics are typical for a toroid core.
 Product specification will differ from these data due to the influence of geometry and size.

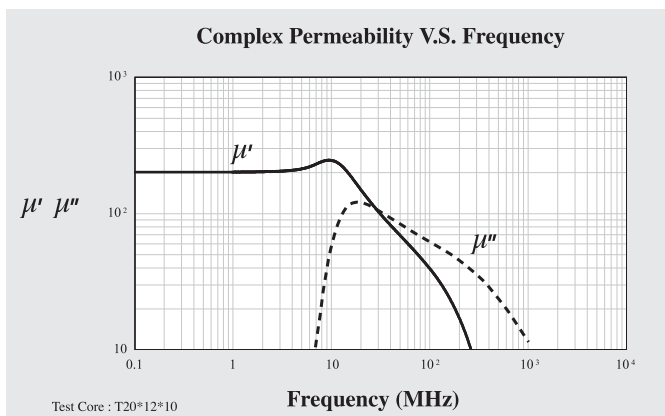
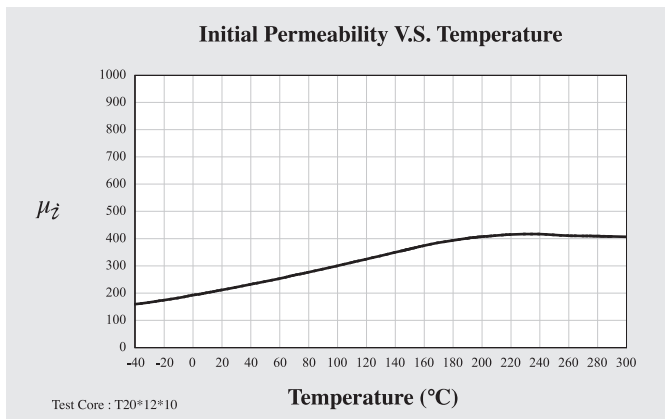
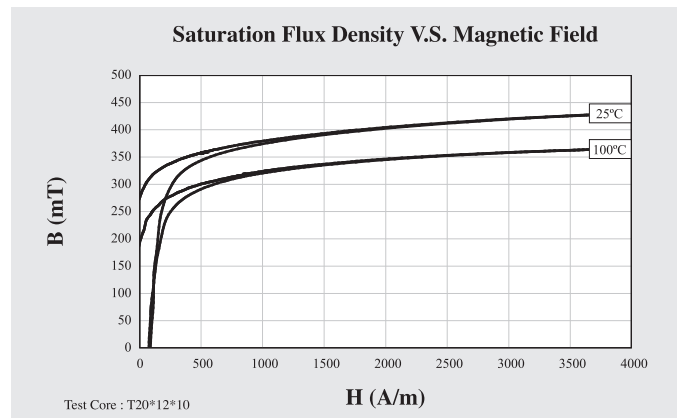
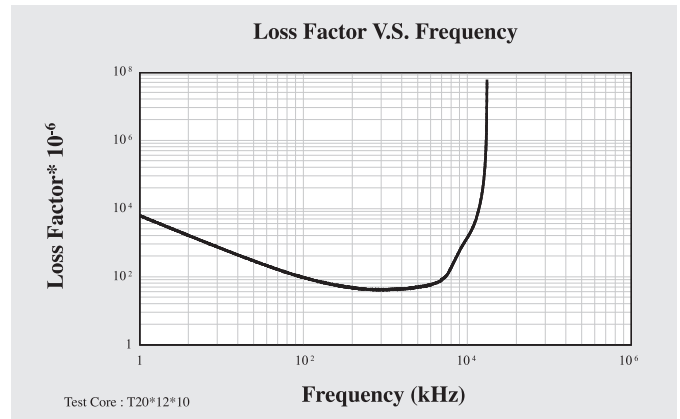

	Symbol	Unit	Measuring Conditions			Rod Core Material
			Freq.	Flux den.	Temp.	H5R
Initial Permeability	μ_z		$\leq 10\text{kHz}$	0.25mT	25°C	200 \pm 25%
Relative Loss Factor	$\tan\delta/\mu_z$	10^{-6}	1kHz		25°C	50
Saturation Flux Density	Bms	mT	1kHz	H = 4000A/m	25°C	400
					100°C	330
Remanence	Brms	mT	1kHz	H = 4000A/m	25°C	320
					100°C	230
Coercivity	Hc	A/m	1kHz	H = 4000A/m	25°C	55
					100°C	32
Temperature Factor of Permeability	αF	$10^{-6}/^\circ\text{C}$			20 ~ 80°C	25
Curie Temperature	Tc	°C				240
Resistivity	ρ	Ωm				10^6
Density	d	g/cm^3				5.10

Note: Material characteristics are typical for a toroid core.
 Product specification will differ from these data due to the influence of geometry and size.

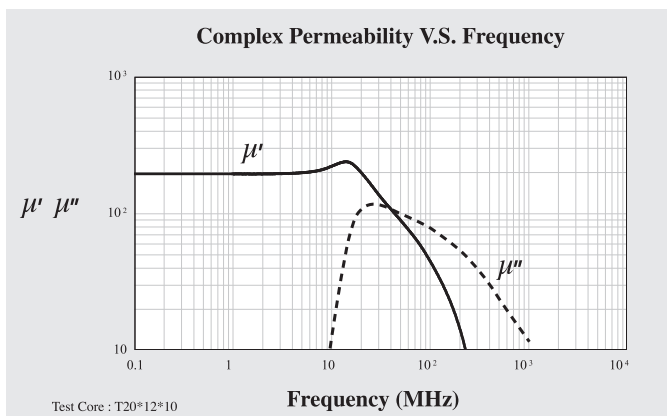
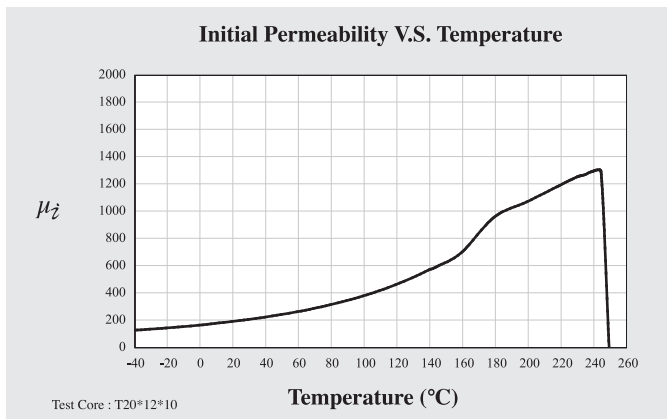
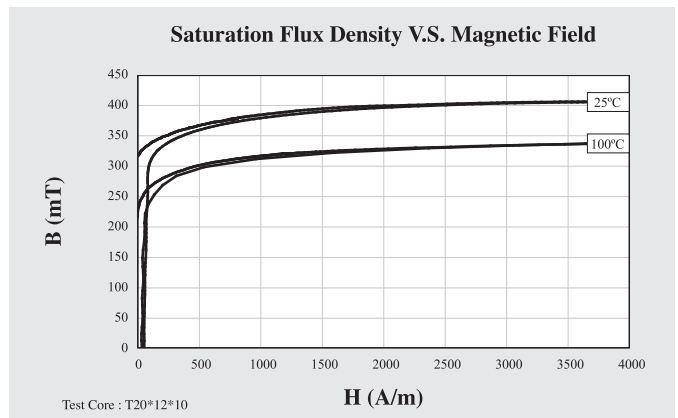
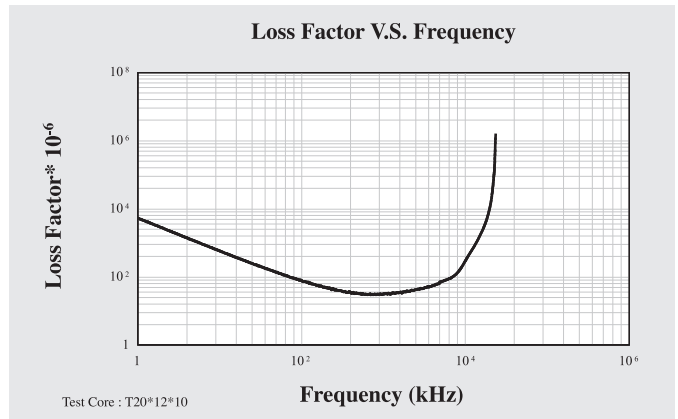

	Symbol	Unit	Measuring Conditions			Wide Temperature Antenna Material
			Freq.	Flux den.	Temp.	F50
Initial Permeability	μ_i		$\leq 10\text{kHz}$	0.25mT	25°C	500 \pm 25%
Saturation Flux Density	Bms	mT	1kHz	H = 4000A/m	25°C	332
Remanence	Brms	mT	1kHz	H = 4000A/m	25°C	127
Coercivity	Hc	A/m	1kHz	H = 4000A/m	25°C	51
Relative Loss Factor	$\tan\delta/\mu_i$	10^{-6}	0.1MHz	< 0.25mT	25°C	21
Temperature Factor of Permeability	αF	$10^{-6}/^\circ\text{C}$			20 ~ 60°C	1
Curie Temperature	Tc	°C				130
Resistivity	ρ	Ωm				> 10^6
Density	d	g/cm^3				5.10

Note: Material characteristics are typical for a toroid core.
 Product specification will differ from these data due to the influence of geometry and size.

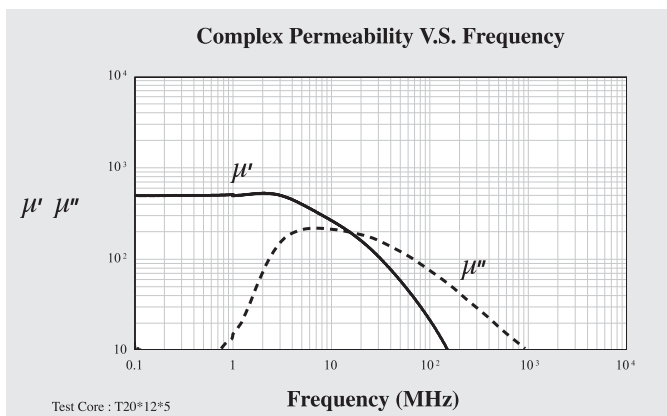
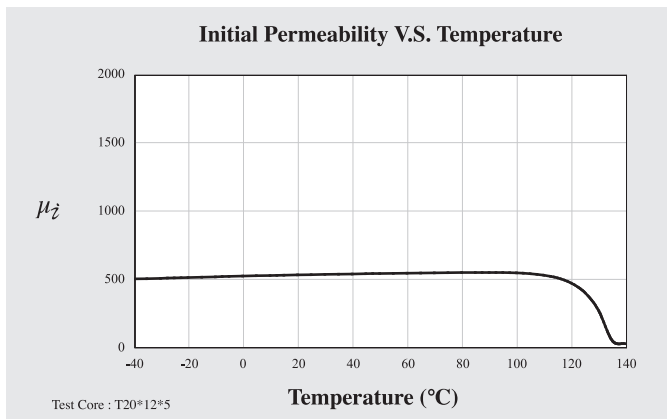
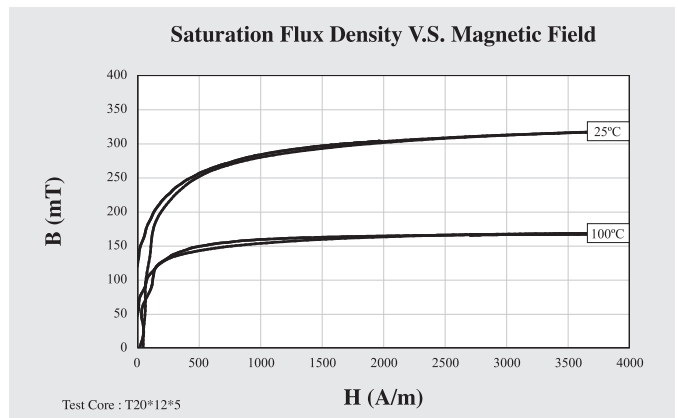
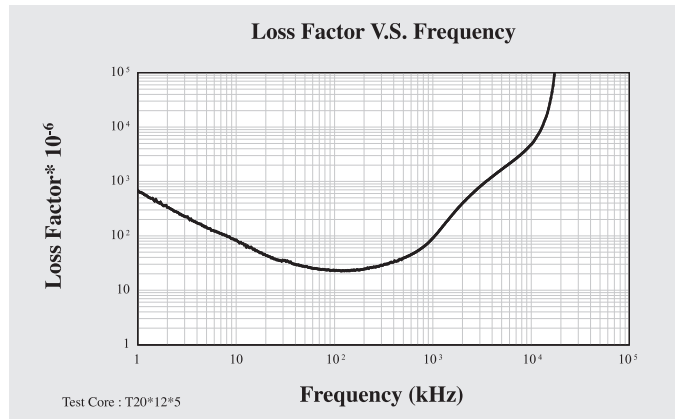

	Symbol	Unit	Measuring Conditions			Wide Temperature Antenna Material
			Freq.	Flux den.	Temp.	F51
Initial Permeability	μ_i		$\leq 10\text{kHz}$	0.25mT	25°C	500 \pm 25%
Saturation Flux Density	Bms	mT	1kHz	H = 4000A/m	25°C	338
Remanence	Brms	mT	1kHz	H = 4000A/m	25°C	118
Coercivity	Hc	A/m	1kHz	H = 4000A/m	25°C	49
Relative Loss Factor	$\tan\delta/\mu_i$	10^{-6}	0.1MHz	< 0.25mT	25°C	20
Temperature Factor of Permeability	α_F	$10^{-6}/^\circ\text{C}$			20 ~ 60°C	-1.3
Curie Temperature	Tc	°C				140
Resistivity	ρ	Ωm				> 10^6
Density	d	g/cm^3				5.10

Note: Material characteristics are typical for a toroid core.
 Product specification will differ from these data due to the influence of geometry and size.

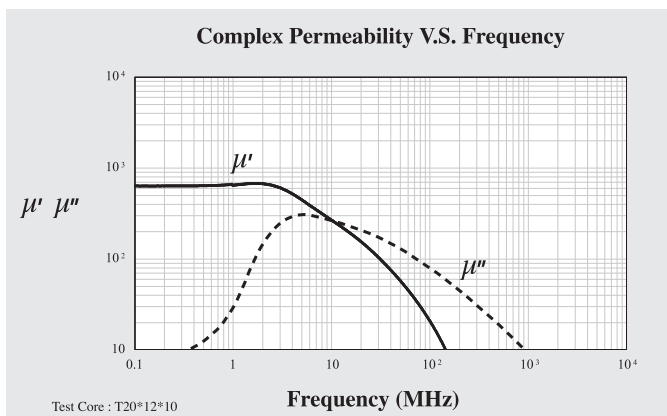
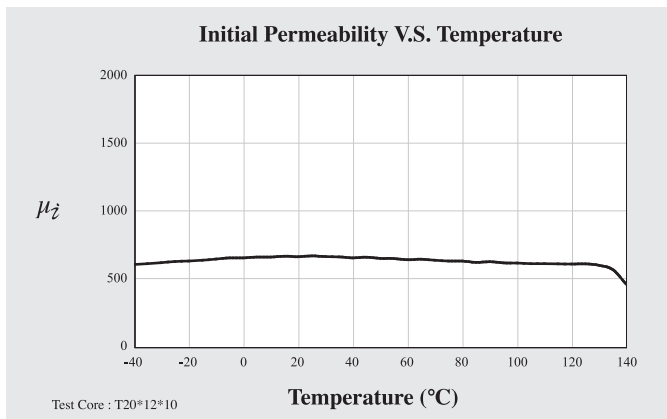
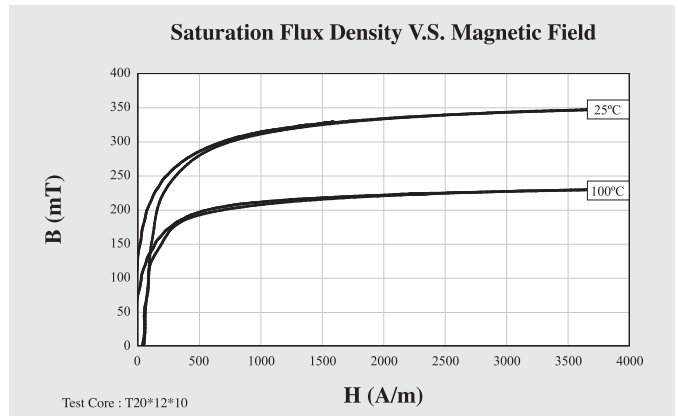
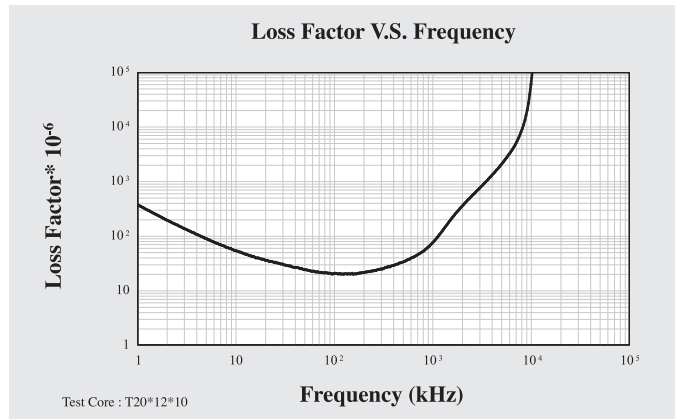

	Symbol	Unit	Measuring Conditions			Low μ Material
			Freq.	Flux den.	Temp.	L1
Initial Permeability	μ_z		$\leq 10\text{kHz}$	0.25mT	25°C	150 \pm 25%
Saturation Flux Density	Bms	mT	1kHz	H = 4000A/m	25°C	410
Remanence	Brms	mT	1kHz	H = 4000A/m	25°C	168
Coercivity	Hc	A/m	1kHz	H = 4000A/m	25°C	105
Relative Loss Factor	$\tan\delta/\mu_z$	10^{-6}	10kHz	< 0.25mT	25°C	180
Curie Temperature	Tc	°C				250
Resistivity	ρ	Ωm				> 10^6
Density	d	g/cm^3				5.10

Note: Material characteristics are typical for a toroid core.
 Product specification will differ from these data due to the influence of geometry and size.

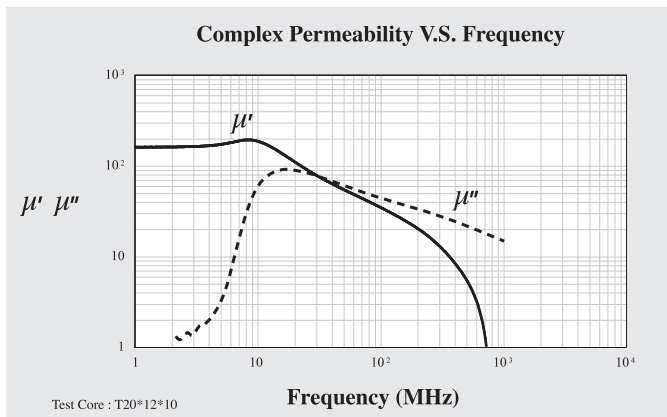
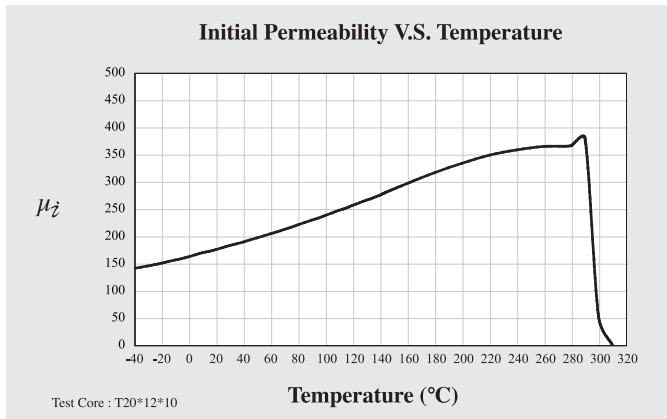
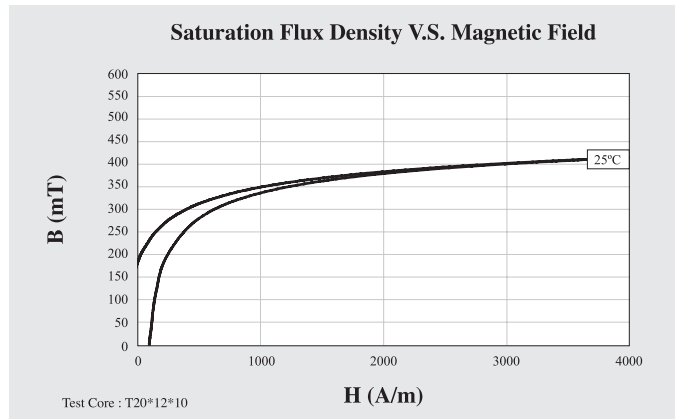
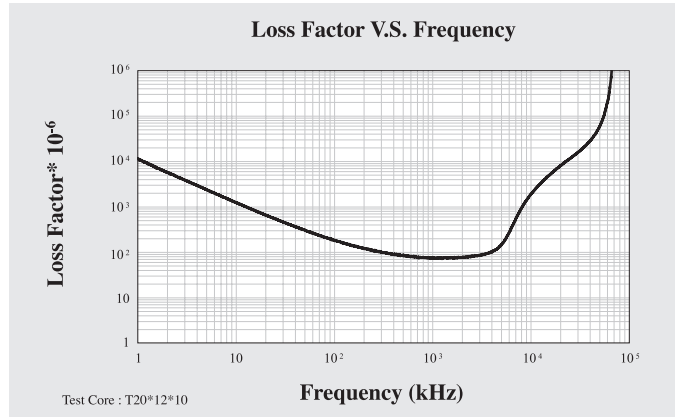

	Symbol	Unit	Measuring Conditions			Low μ Material
			Freq.	Flux den.	Temp.	L2
Initial Permeability	μ_z		$\leq 10\text{kHz}$	0.25mT	25°C	$60 \pm 25\%$
Saturation Flux Density	Bms	mT	1kHz	H = 4000A/m	25°C	421
Remanence	Brms	mT	1kHz	H = 4000A/m	25°C	274
Coercivity	Hc	A/m	1kHz	H = 4000A/m	25°C	141
Relative Loss Factor	$\tan\delta/\mu_z$	10^{-6}	10MHz	$< 0.25\text{mT}$	25°C	150
Curie Temperature	Tc	°C				250
Resistivity	ρ	Ωm				$> 10^6$
Density	d	g/cm^3				5.10

Note: Material characteristics are typical for a toroid core.
 Product specification will differ from these data due to the influence of geometry and size.

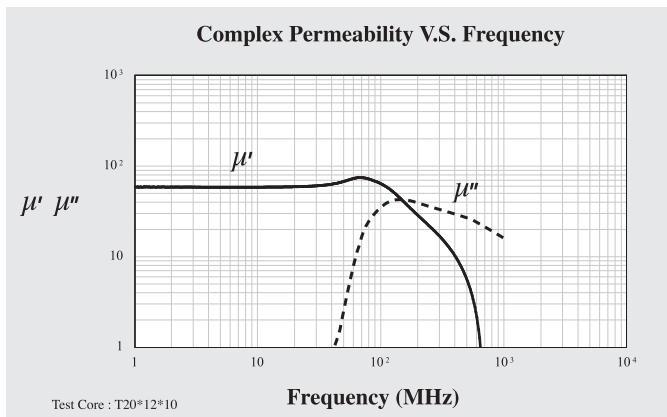
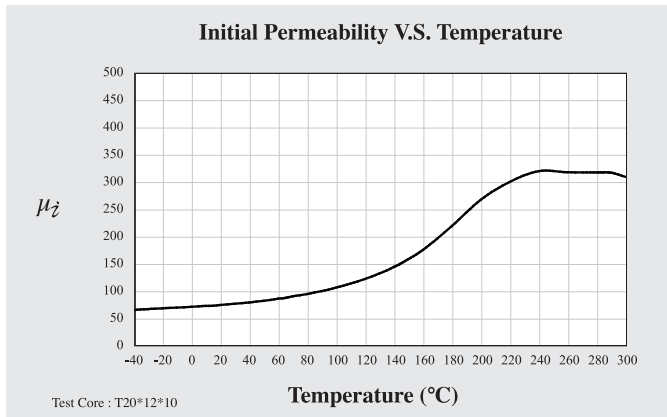
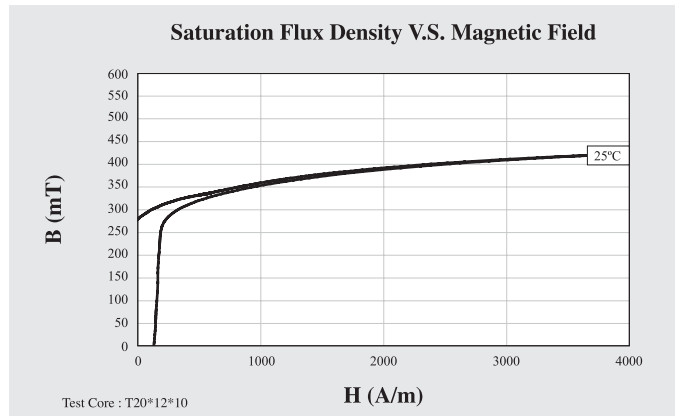
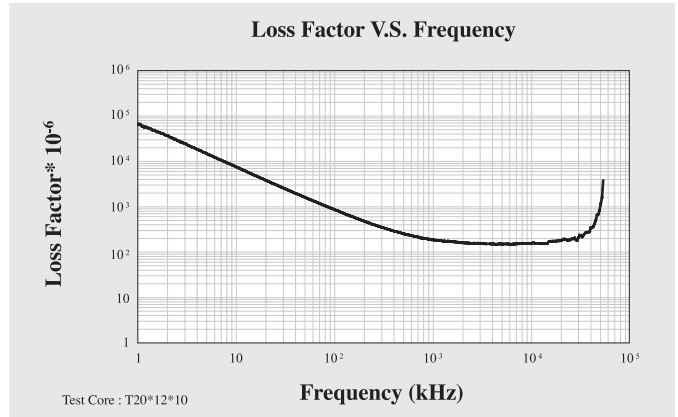

	Symbol	Unit	Measuring Conditions			Low μ Material
			Freq.	Flux den.	Temp.	L3
Initial Permeability	μ_i		$\leq 10\text{kHz}$	0.25mT	25°C	20 \pm 25%
Saturation Flux Density	B _{ms}	mT	1kHz	H = 8000A/m	25°C	306
Remanence	B _{rms}	mT	1kHz	H = 8000A/m	25°C	122
Coercivity	H _c	A/m	1kHz	H = 8000A/m	25°C	600
Relative Loss Factor	$\tan\delta/\mu_i$	10 ⁻⁶	10MHz	< 0.25mT	25°C	448
Curie Temperature	T _c	°C				300
Resistivity	ρ	Ωm				> 10 ⁶
Density	d	g/cm ³				5.10

Note: Material characteristics are typical for a toroid core.
 Product specification will differ from these data due to the influence of geometry and size.

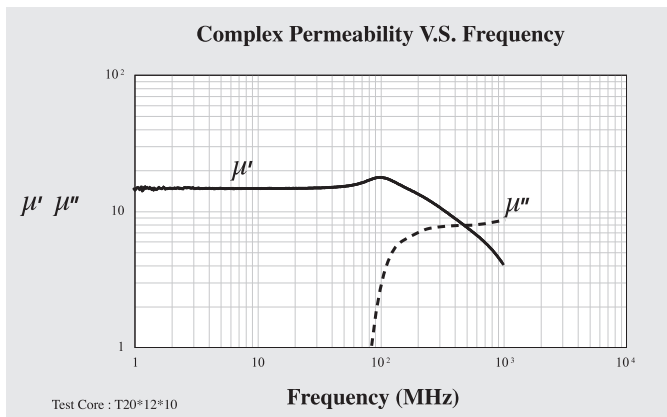
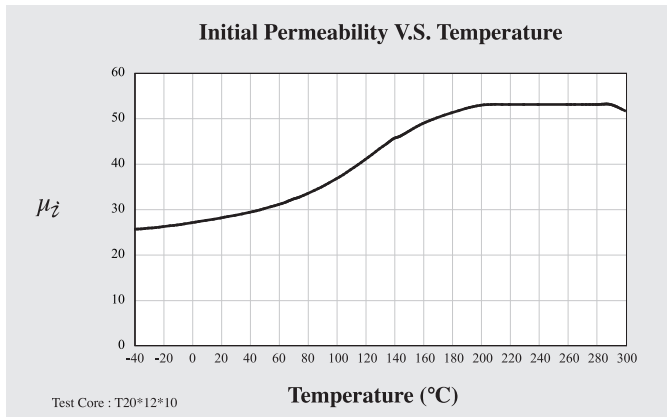
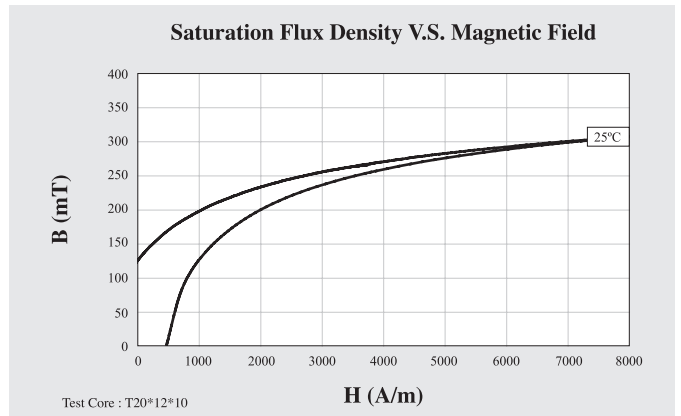
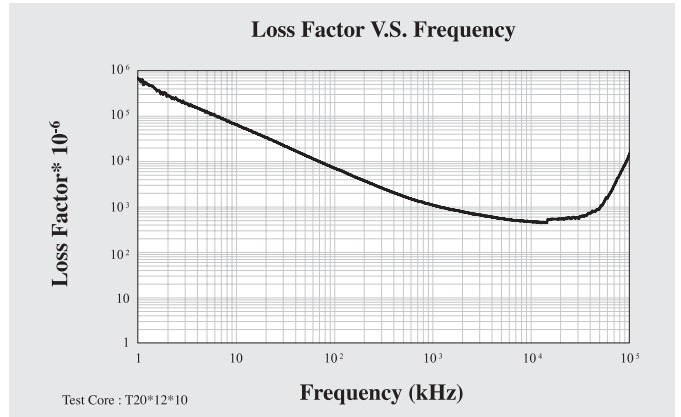

	Symbol	Unit	Measuring Conditions			Low μ Material
			Freq.	Flux den.	Temp.	L4
Initial Permeability	μ_z		$\leq 10\text{kHz}$	0.25mT	25°C	50 \pm 25%
Saturation Flux Density	Bms	mT	1kHz	H = 4000A/m	25°C	395
Remanence	Brms	mT	1kHz	H = 4000A/m	25°C	255
Coercivity	Hc	A/m	1kHz	H = 4000A/m	25°C	200
Relative Loss Factor	$\tan\delta/\mu_z$	10^{-6}	10MHz	< 0.25mT	25°C	169
Curie Temperature	Tc	°C				300
Resistivity	ρ	Ωm				> 10^6
Density	d	g/cm^3				5.10

Note: Material characteristics are typical for a toroid core.
 Product specification will differ from these data due to the influence of geometry and size.

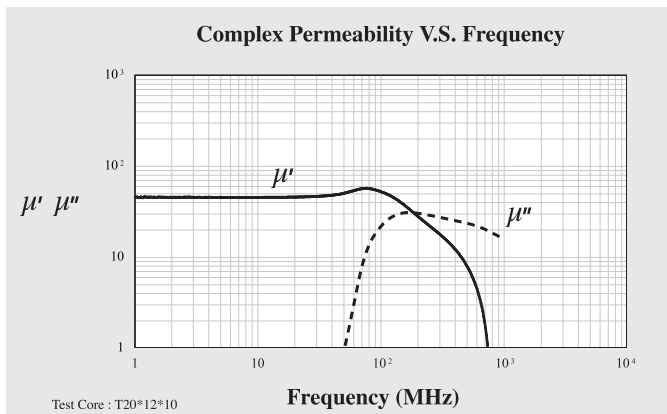
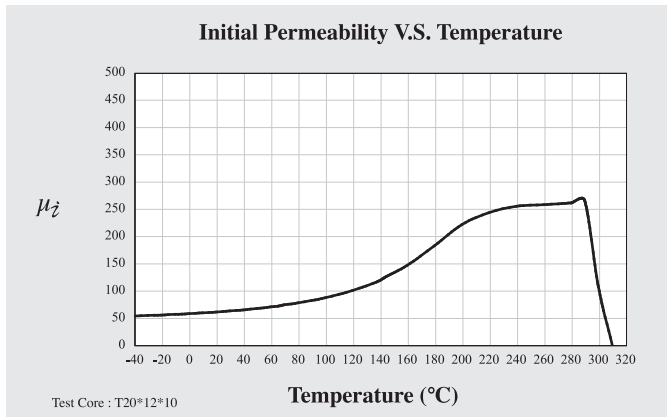
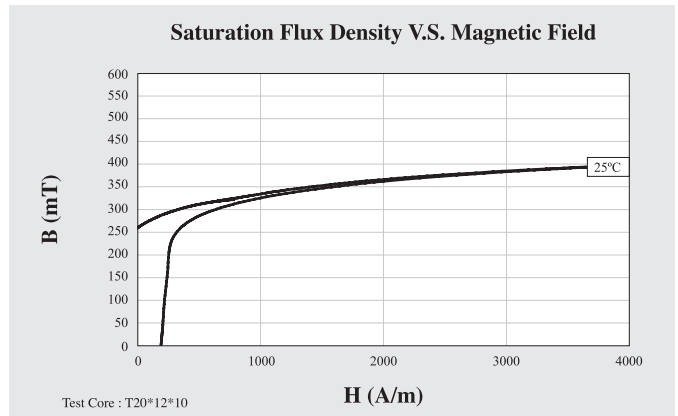
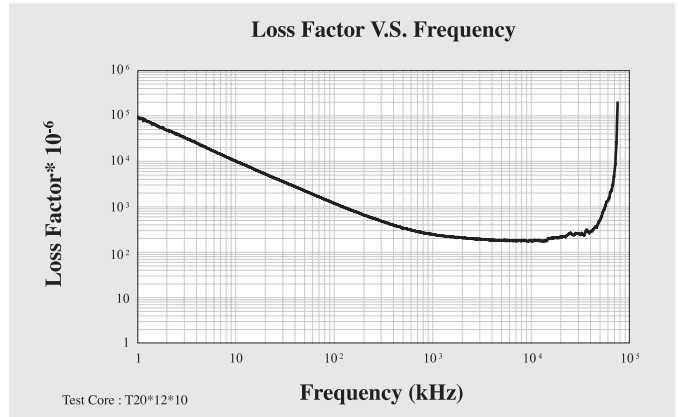

	Symbol	Unit	Measuring Conditions			Low μ Material
			Freq.	Flux den.	Temp.	L5
Initial Permeability	μ_z		$\leq 10\text{kHz}$	0.25mT	25°C	100 \pm 25%
Saturation Flux Density	Bms	mT	1kHz	H = 4000A/m	25°C	390
Remanence	Brms	mT	1kHz	H = 4000A/m	25°C	175
Coercivity	Hc	A/m	1kHz	H = 4000A/m	25°C	140
Relative Loss Factor	$\tan\delta/\mu_z$	10 ⁻⁶	10kHz	< 0.25mT	25°C	350
Curie Temperature	Tc	°C				250
Resistivity	ρ	Ωm				> 10 ⁶
Density	d	g/cm ³				5.10

Note: Material characteristics are typical for a toroid core.
 Product specification will differ from these data due to the influence of geometry and size.

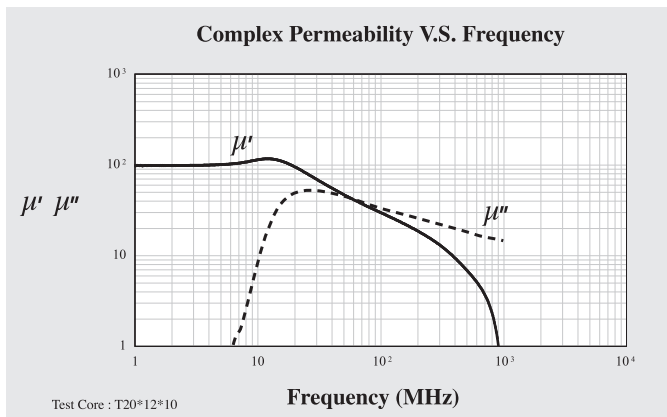
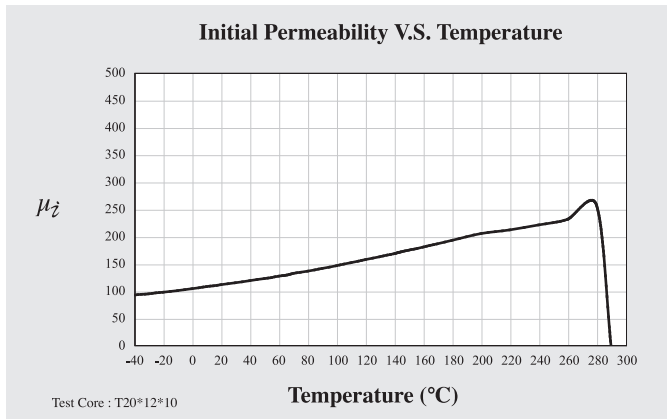
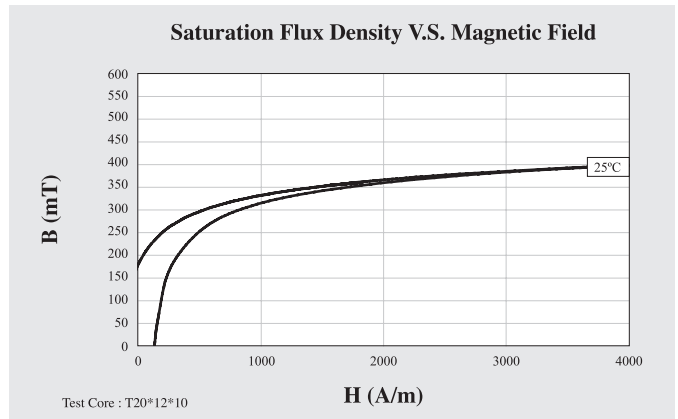
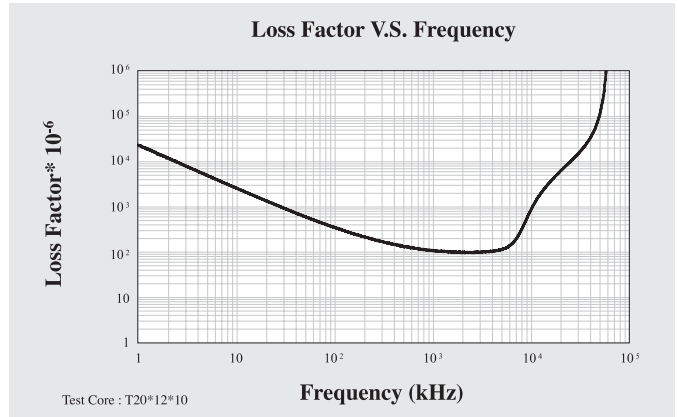

	Symbol	Unit	Measuring Conditions			Low μ Material
			Freq.	Flux den.	Temp.	L6
Initial Permeability	μ_z		$\leq 10\text{kHz}$	0.25mT	25°C	14 \pm 25%
Saturation Flux Density	Bms	mT	1kHz	H = 8000A/m	25°C	266
Remanence	Brms	mT	1kHz	H = 8000A/m	25°C	175
Coercivity	Hc	A/m	1kHz	H = 8000A/m	25°C	1540
Relative Loss Factor	$\tan\delta/\mu_z$	10 ⁻⁶	10MHz	< 0.25mT	25°C	707
Curie Temperature	Tc	°C				300
Resistivity	ρ	Ωm				> 10 ⁶
Density	d	g/cm ³				5.10

Note: Material characteristics are typical for a toroid core.
 Product specification will differ from these data due to the influence of geometry and size.

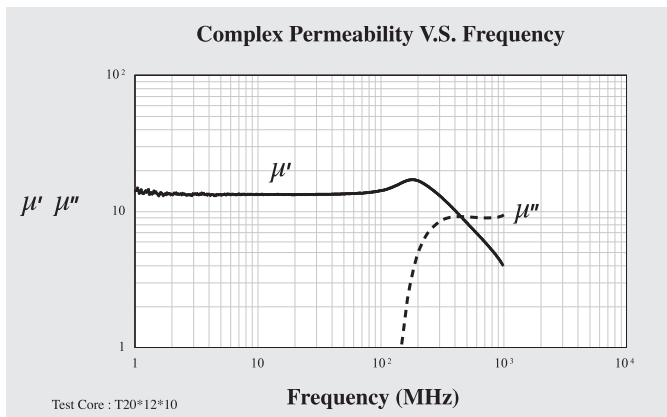
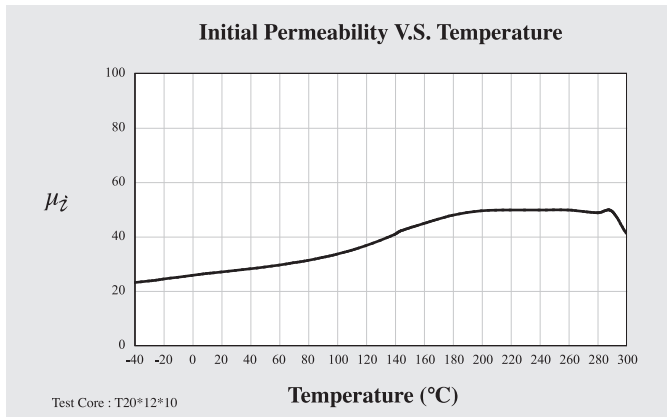
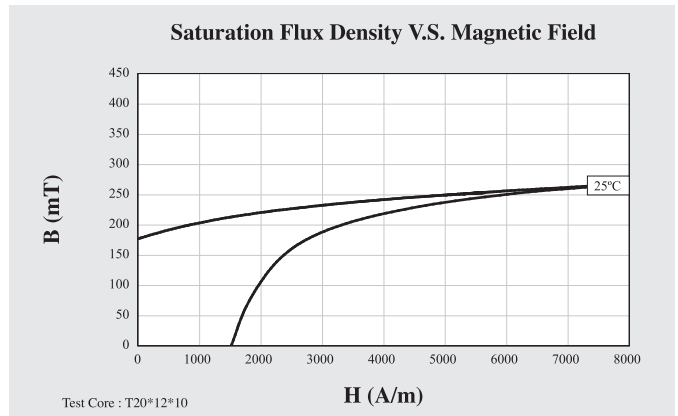
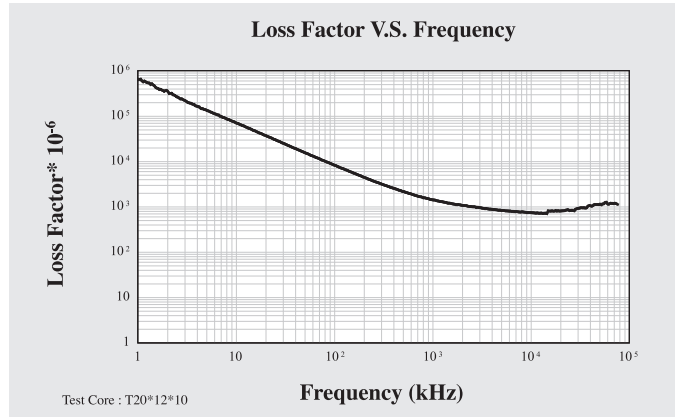

Type : EFD Cores (1)

Ordering Code:

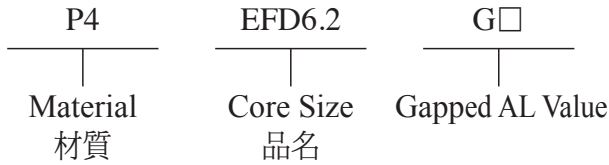

Shape:

Type:1

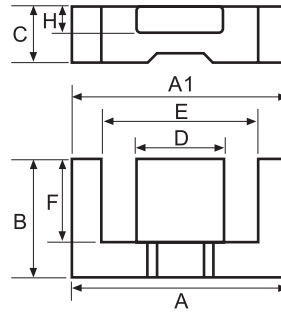

Type:2

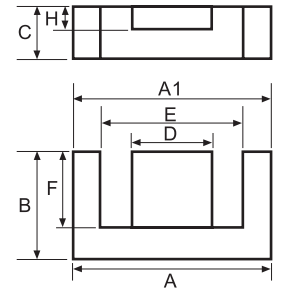

Type:3

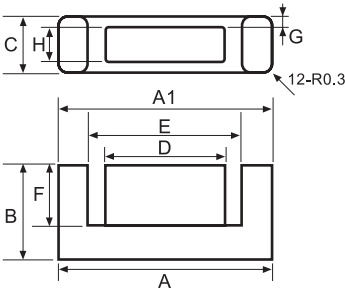

Type:4

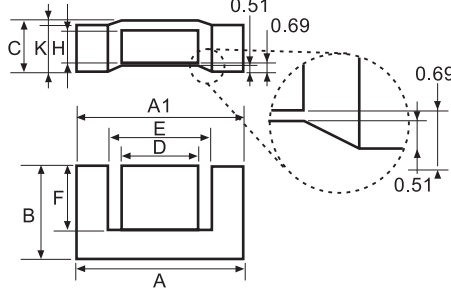

Type:5

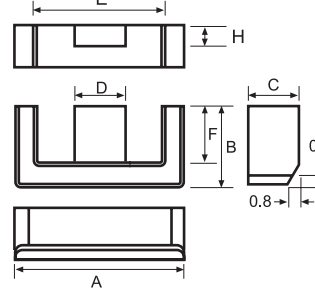

Type:6

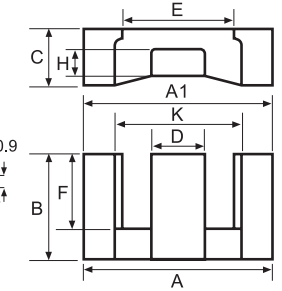

■ DIMENSIONS

CORES	DIMENSIONS (mm)										Type
	A	B	C	D	E	F	G	H	K	A-A1	
EFD6.2	6.25 ± 0.15	3.15 ± 0.10	2.50 ± 0.10	2.50 ± 0.10	4.85 ± 0.15	2.30 ± 0.10	-	1.25 ± 0.10	-	0.15max	2
EFD6.4	6.40 ± 0.15	3.70 ± 0.10	2.90 ± 0.10	2.35 ± 0.10	5.30 ± 0.15	2.90 ± 0.10	-	1.40 ± 0.10	-	-	2
EFD6.5	6.50 ± 0.15	3.65 ± 0.10	3.00 ± 0.10	2.50 ± 0.10	5.20 ± 0.15	2.85 ± 0.10	-	1.70 ± 0.10	-	-	2
EFD6.5-1	6.55 ± 0.15	3.65 ± 0.10	3.00 ± 0.10	2.50 ± 0.10	5.25 ± 0.15	2.85 ± 0.10	-	1.70 ± 0.10	-	0.15max	2
EFD7.5	7.50 ± 0.30	4.05 ± 0.15	2.30 ± 0.15	2.50 ± 0.15	5.70 ± 0.20	2.75 ± 0.15	-	1.15 ± 0.15	-	-	5
EFD8.0	8.00 ± 0.15	3.70 ± 0.10	1.90 ± 0.10	3.40 ± 0.10	5.90 min	2.30 ± 0.10	-	0.90 ± 0.10	-	0.15max	2
EFD9.2A	9.20 ± 0.20	4.50 ± 0.10	1.90 ± 0.10	5.10 ± 0.15	6.60 ± 0.15	3.10 ± 0.10	0.50 ± 0.10	0.90 ± 0.10	-	-	3
EFD9.5	9.60 ± 0.15	4.60 ± 0.10	2.20 ± 0.10	4.00 ± 0.10	7.35 ± 0.15	3.00 ± 0.10	-	1.15 ± 0.10	-	≤ 0.13mm	1
EFD9.8	9.80 ± 0.15	9.80 ± 0.10	2.50 ± 0.10	4.50 ± 0.10	7.40 ± 0.15	7.80 ± 0.10	-	1.31 ± 0.10	-	0.15max	2
EFD10.7	10.70 ± 0.20	6.50 ± 0.10	3.50 ± 0.15	3.20 ± 0.10	8.30 ± 0.15	5.15 ± 0.10	-	1.50 ± 0.10	-	-	2
EFD11.2A	11.20 ^{+0.20} / _{-0.25}	5.70 ± 0.12	2.70 ± 0.20	4.90 ^{+0.10} / _{-0.15}	8.70 ± 0.20	3.95 ± 0.10	-	1.40 ^{+0.10} / _{-0.15}	-	-	2
EFD11.3	11.30 ± 0.20	6.70 ± 0.20	3.50 ± 0.15	3.20 ± 0.15	8.50 min	5.20 ± 0.10	-	1.50 ± 0.10	-	-	2
EFD11.7/13.6	11.75 ± 0.15	13.60 ± 0.15	2.38 ± 0.15	5.00 ± 0.10	8.65 ± 0.15	11.60 ± 0.10	-	1.50 ± 0.10	-	≤ 0.20mm	2
EFD12	12.50 ± 0.30	6.20 ± 0.10	3.50 ± 0.10	5.40 ± 0.15	9.00 ± 0.25	4.55 ± 0.15	-	2.00 ± 0.10	-	0.20max	1
EFD12.2A	12.20 ± 0.25	7.60 ± 0.20	3.50 ± 0.15	3.30 ± 0.15	9.80 ± 0.25	6.35 ± 0.15	-	2.00 ± 0.15	-	≤ 0.25mm	2
EFD12A/3.5	12.00 ± 0.20	7.70 ± 0.15	3.50 ± 0.15	3.20 ± 0.10	9.35 min	6.30 ± 0.15	-	1.50 ± 0.10	-	0.15max	2
EFD12.4B	12.40 ^{+0.30} / _{-0.20}	6.05 ± 0.20	4.00 ± 0.10	5.15 ± 0.15	9.70min	4.60 ± 0.15	-	2.20 ± 0.10	-	-	2
EFD12.45	12.45 ± 0.25	6.20 ± 0.15	3.90 ± 0.08	5.80 ± 0.12	7.75 ± 0.15	4.05 ± 0.10	-	2.55 ± 0.05	3.50 ± 0.06	-	4
EFD12.7	12.75 ± 0.25	6.85 ± 0.15	3.30 ± 0.15	6.00 ± 0.10	9.35 ± 0.15	4.55 ± 0.15	-	1.85 ± 0.10	-	≤ 0.20mm	2
EFD12.7A	12.70 ± 0.20	10.60 ± 0.15	5.40 ± 0.15	4.50 ^{+0.10} / _{-0.15}	8.90 ^{+0.20} / _{-0.10}	8.20 ± 0.15	-	3.50 ± 0.10	-	0.15max	2
EFD13	13.20 ± 0.35	6.85 ± 0.15	2.85 ± 0.15	5.25 ± 0.15	9.60 ^{+0.15} / _{-0.25}	4.80 ± 0.15	-	1.40 ± 0.10	-	≤ 0.30mm	1
EFD13.3	13.35 ± 0.25	5.65 ± 0.15	3.80 ± 0.15	6.65 ± 0.15	10.00 ± 0.20	3.80 ± 0.20	-	1.65 ± 0.10	10.40 ± 0.20	≤ 0.30mm	6
EFD13.5A	13.50 ^{+0.20} / _{-0.15}	11.00 ^{+0.15} / _{-0.10}	4.50 ± 0.10	5.30 ± 0.10	9.80 min	8.55 ± 0.10	-	3.00 ± 0.10	-	0.20max	2
EFD13.5B	13.50 ^{+0.20} / _{-0.15}	11.55 ^{+0.15} / _{-0.10}	3.80 ± 0.10	5.30 ± 0.10	9.80 min	9.05 ± 0.10	-	2.70 ± 0.10	-	0.20max	2
EFD13.8	14.00 ± 0.35	8.65 ± 0.15	3.35 ± 0.15	5.60 ± 0.15	10.60 ± 0.30	6.45 ^{+0.15} / _{-0.10}	-	1.60 ± 0.10	-	≤ 0.20mm	1

■ EFFECTIVE PARAMETERS

CORES	EFFECTIVE PARAMETERS				
	C ₁ (mm ⁻¹)	Le(mm)	Ae(mm ²)	Ve(mm ³)	Wt(g/set)
EFD6.2	4.47	14.26	3.19	45.49	0.27
EFD6.4	5.11	17.05	3.34	56.91	0.15
EFD6.5	4.25	16.77	3.95	66.24	0.73
EFD6.5-1	4.26	16.82	3.95	66.44	0.39
EFD7.5	4.98	17.15	3.44	59.07	0.40
EFD8.0	4.85	15.95	3.29	52.48	0.38
EFD9.2A	4.27	18.80	4.40	82.70	0.52
EFD9.5	4.06	20.10	4.80	97.50	0.56
EFD9.8	6.54	39.64	6.06	240.22	1.30
EFD10.7	4.87	28.02	5.75	161.12	1.14
EFD11.2A	3.60	25.05	6.96	174.40	0.98
EFD11.3	4.60	28.40	6.18	175.50	0.92
EFD11.7/13.6	7.57	56.28	7.43	418.16	2.10
EFD12	2.59	27.42	10.55	289.20	1.62
EFD12.2A	3.94	32.29	8.19	264.46	1.50
EFD12A/3.5	5.47	33.18	6.07	201.38	1.34
EFD12.4B	2.61	27.88	10.68	297.89	1.64
EFD12.45	1.66	25.60	15.40	394.20	2.10
EFD12.7	2.57	28.68	11.13	319.20	1.80
EFD12.7A	2.42	43.33	17.93	776.91	4.39
EFD13	3.57	29.28	8.18	239.50	1.53
EFD13.3	2.15	25.10	11.65	292.42	1.64
EFD13.5A	2.78	45.97	16.54	760.34	4.04
EFD13.5B	3.33	48.03	14.44	693.55	3.62
EFD13.8	3.75	36.98	9.84	363.80	2.04

■ ELECTRICAL CHARACTERISTICS

CORES	AL ± 25% (nH/N ²)									AL + 40% - 30% (nH/N ²)		
	P4	P41	P46	P47	P48	P5	N42	A05	A07	A10(L)	A121(L)	A151(L)
EFD6.2	390	345										
EFD6.4	400											
EFD6.5	400				350							
EFD6.5-1	380	370										
EFD7.5			420									
EFD8.0		355	380									
EFD9.2A	440											
EFD9.5	460											
EFD9.8	300											
EFD10.7									800	1900		
EFD11.2A							800					
EFD11.3									1000			
EFD11.7/13.6	340											
EFD12	850	820	900	850		700						
EFD12.2A									1050			
EFD12A/3.5									767			
EFD12.4B	800											
EFD12.45	1200						1400					
EFD12.7	950					810			4000			
EFD12.7A	940											
EFD13	600					500						
EFD13.3	900			1050								
EFD13.5A	890											
EFD13.5B	750											
EFD13.8	600											

Remark:

1. AL Value Testing Condition : 10kHz, 50mV, 100Ts. If testing condition is different from ACME's, please specify upon request & ordering.
2. Gapped core is available, please specify upon request & ordering. ACME's standard gapped core set is a combination of one gapped core and one ungapped core. If gapping on both pcs to make a set is needed, please specify upon request & ordering.
3. L : Mirror Finished Lapping. Please specify upon request & ordering by adding "L" at the end of Core Size if you need.

Type : EFD Cores (2)

Ordering Code:

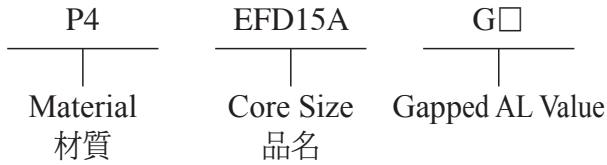

Shape:

Type:3

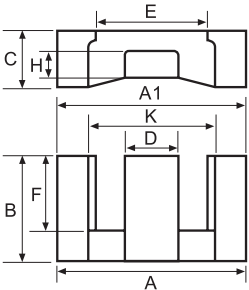

Type:4

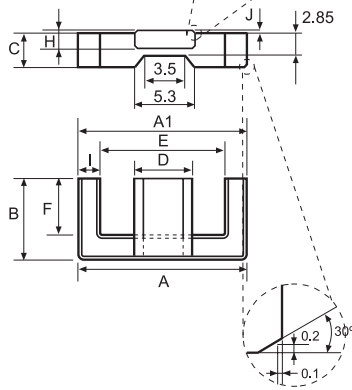

Type:5

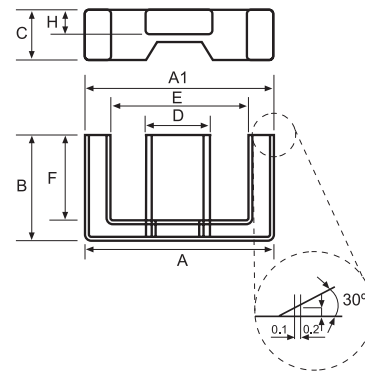

Type:2

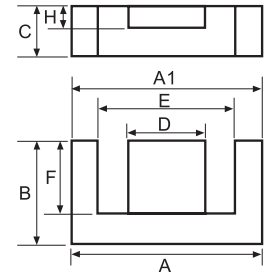

Type:6

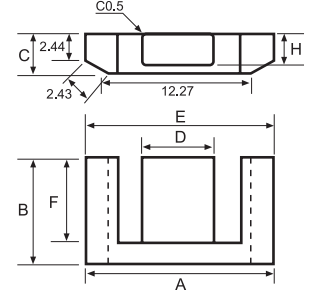

■ DIMENSIONS

CORES	DIMENSIONS (mm)									Type
	A	B	C	D	E	F	H	K	A-A1	
EFD14.6	14.60 ± 0.30	7.30 ± 0.15	6.20 ± 0.15	5.30 ± 0.15	11.00 ± 0.35	5.30 ± 0.25	4.24 ± 0.10	-	≤ 0.20mm	2
EFD14.7/4.75	14.70 ± 0.30	12.70 ± 0.15	4.75 ± 0.15	6.00 ± 0.15	10.45 ± 0.15	10.00 ^{+0.15} _{-0.10}	3.30 ± 0.10	-	0.25max	2
EFD14.8	14.80 ± 0.60	9.00 ± 0.20	6.80 ± 0.20	5.60 ± 0.20	11.10 ± 0.30	6.15 ± 0.10	4.60 ± 0.20	-	0.30max	2
EFD14.8B	14.80 ± 0.30	10.00 ± 0.15	4.60 ± 0.10	6.00 ± 0.15	11.05 ± 0.15	7.80 ^{+0.13} _{-0.12}	2.70 ± 0.10	-	0.25max	2
EFD15A	15.00 ± 0.40	7.50 ± 0.15	4.65 ± 0.15	5.30 ± 0.15	11.00 ± 0.25	5.50 ^{+0.25} _{-0.10}	2.40 ± 0.10	-	≤ 0.15mm	4
EFD15C/4.2	15.00 ^{+0.25} _{-0.15}	14.45 ^{+0.15} _{-0.10}	4.20 ^{+0.08} _{-0.07}	5.80 ± 0.07	10.60 ± 0.15	12.15 ± 0.10	2.90 ± 0.07	-	-	2
EFD15D	15.00 ^{+0.25} _{-0.15}	14.35 ^{+0.15} _{-0.10}	4.00 ^{+0.08} _{-0.07}	5.80 ± 0.07	10.60 ± 0.15	12.05 ± 0.10	2.70 ± 0.07	-	≤ 0.15mm	2
EFD15E	15.00 ± 0.25	14.95 ± 0.15	4.00 ± 0.10	5.80 ± 0.10	10.60 ± 0.15	12.65 ± 0.15	2.70 ± 0.10	-	-	2
EFD15H	15.00 ± 0.40	7.50 ± 0.15	4.50 ± 0.15	5.30 ± 0.15	11.00 ± 0.25	5.50 ^{+0.25} _{-0.10}	2.15 ± 0.10	-	≤ 0.25max	5
EFD15.3	15.00 ± 0.30	6.45 ± 0.05	3.70 ± 0.10	7.90 ± 0.10	11.25 ± 0.25	4.73 ± 0.10	1.60 ± 0.10	12.05 ± 0.25	≤ 0.20mm	3
EFD15.3A	15.35 ± 0.25	6.55 ± 0.15	3.70 ± 0.15	8.05 ± 0.20	11.70 ± 0.30	4.50 ± 0.15	1.60 ± 0.10	12.50 ± 0.30	-	3
EFD16	16.00 ± 0.25	15.10 ^{+0.15} _{-0.10}	4.00 ± 0.15	5.80 ± 0.10	12.00 ± 0.15	12.70 ± 0.10	2.70 ± 0.10	-	0.25max	2
EFD16A	16.00 ± 0.30	7.20 ± 0.20	4.80 ± 0.20	6.00 ± 0.25	12.50 ± 0.30	5.10 ± 0.20	2.40 ± 0.20	-	-	2
EFD16B	16.00 ± 0.25	15.30 ± 0.20	4.00 ± 0.15	5.50 ± 0.15	10.20min	12.30 ± 0.20	3.00 ± 0.13	-	-	6
EFD16.5	16.55 ± 0.25	19.40 ± 0.25	4.45 ± 0.10	5.80 ± 0.20	11.40min	16.45 ^{+0.20} _{-0.15}	2.80 ± 0.10	-	≤ 0.20mm	1
EFD16.5/17	16.55 ± 0.25	17.00 ± 0.25	4.45 ± 0.10	5.80 ± 0.20	11.40min	14.05 ^{+0.20} _{-0.15}	2.80 ± 0.10	-	-	2
EFD16.5/50	16.55 ± 0.25	25.00 ± 0.15	4.45 ± 0.15	5.80 ± 0.15	11.40min	22.00 ^{+0.20} _{-0.15}	2.80 ± 0.10	-	-	1
EFD17.6	17.60 ± 0.30	11.00 ± 0.20	5.60 ± 0.15	7.50 ± 0.15	13.10min	8.60 ± 0.20	3.40 ± 0.10	-	≤ 0.25mm	2
EFD17.7A	17.70 ± 0.30	10.10 ± 0.15	5.60 ± 0.12	7.50 ± 0.15	13.50 ± 0.25	7.80 ± 0.15	3.40 ± 0.10	-	≤ 0.20mm	2
EFD18	18.00 ± 0.30	11.20 ± 0.15	2.00 ± 0.10	9.00 ± 0.15	13.20 ± 0.15	7.90 ± 0.15	0.90 ± 0.10	-	≤ 0.20mm	2
EFD18.5	18.50 ± 0.50	19.90 ± 0.20	4.05 ± 0.25	7.60 ± 0.20	14.50 ± 0.50	17.80 ± 0.20	2.11 ± 0.15	-	≤ 0.30mm	2
EFD18.5/3.7	18.50 ± 0.30	15.30 ± 0.20	3.70 ± 0.25	7.60 ± 0.20	14.50 ± 0.30	13.10 ± 0.20	1.80 ± 0.15	-	-	1
EFD19.5	19.50 ± 0.35	21.40 ± 0.20	5.45 ± 0.15	5.80 ± 0.15	13.50min	18.20 ± 0.15	4.00 ± 0.15	-	-	2

■ EFFECTIVE PARAMETERS

CORES	EFFECTIVE PARAMETERS				
	C _i (mm ⁻¹)	Le(mm)	Ae(mm ²)	Ve(mm ³)	Wt(g/set)
EFD14.6	1.53	33.45	21.84	730.50	4.08
EFD14.7/4.75	2.61	52.61	20.16	1060.62	5.50
EFD14.8	1.42	37.89	26.65	1009.77	5.80
EFD14.8B	2.55	43.26	16.91	731.34	4.00
EFD15A	2.35	33.28	14.12	469.90	2.74
EFD15C/4.2	3.73	60.69	16.27	987.24	5.18
EFD15D	3.30	60.29	18.26	1101.19	7.00
EFD15E	3.85	62.68	16.27	1020.15	5.26
EFD15H	2.03	29.88	14.70	439.24	2.75
EFD15.3	2.49	28.58	11.44	326.95	1.90
EFD15.3A	2.25	29.11	12.96	377.27	2.80
EFD16	4.10	64.37	15.70	1010.61	5.18
EFD16A	2.24	33.48	14.97	501.35	3.10
EFD16B	3.57	62.64	17.55	1099.42	5.80
EFD16.5	4.18	78.03	18.67	1456.82	8.00
EFD16.5/17	3.73	69.18	18.53	1281.91	7.34
EFD16.5/50	5.42	100.87	18.62	1878.20	8.00
EFD17.6	2.03	48.36	23.84	1152.90	6.12
EFD17.7A	1.94	45.10	23.29	1050.61	5.72
EFD18	5.30	45.54	8.59	391.10	2.46
EFD18.5	5.51	85.28	15.46	1318.43	7.14
EFD18.5/3.7	4.77	66.84	14.02	937.08	2.41
EFD19.5	3.37	88.71	26.32	2335.22	13.08

■ ELECTRICAL CHARACTERISTICS

CORES	AL ± 25% (nH/N ²)							AL + 40% - 30% (nH/N ²)			
	P4	P41	P46	P47	P48	P5	A05	A07	A10(L)	A121(L)	A151(L)
EFD14.6	1000					800			4285		
EFD14.7/4.75	950										
EFD14.8	1400										
EFD14.8B	820										
EFD15A	780 +30% -20%	760 +30% -20%	1060	900 +30% -20%		630 +30% -20%	1400	1820	2540min		3810min
EFD15C/4.2	700										
EFD15D	700										
EFD15E	680										
EFD15H	740										
EFD15.3	850					700					
EFD15.3A	800		950	900							
EFD16	640										
EFD16A	1020										
EFD16B					750						
EFD16.5	678										
EFD16.5/17	700										
EFD16.5/50	590										
EFD17.6	1200										
EFD17.7A	1140										
EFD18	500										
EFD18.5	500										
EFD18.5/3.7	650 (ref)										
EFD19.5	950										

Remark:

1. AL Value Testing Condition : 10kHz, 50mV, 100Ts. If testing condition is different from ACME's, please specify upon request & ordering.
2. Gapped core is available, please specify upon request & ordering. ACME's standard gapped core set is a combination of one gapped core and one ungapped core. If gapping on both pcs to make a set is needed, please specify upon request & ordering.
3. L : Mirror Finished Lapping. Please specify upon request & ordering by adding "L" at the end of Core Size if you need.

Type : EFD Cores (3)

Shape:

Ordering Code:

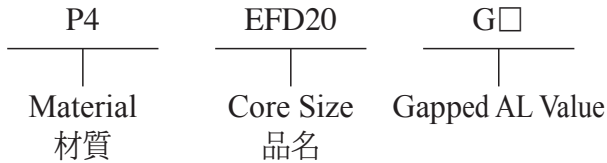

Type:1

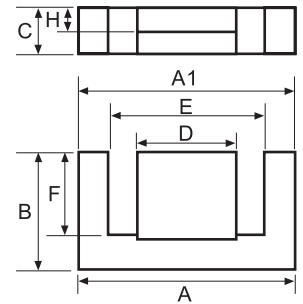

Type:2

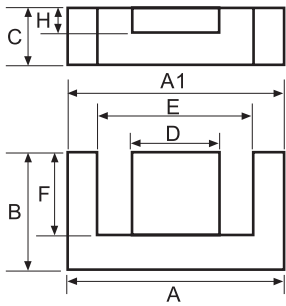

Type:3

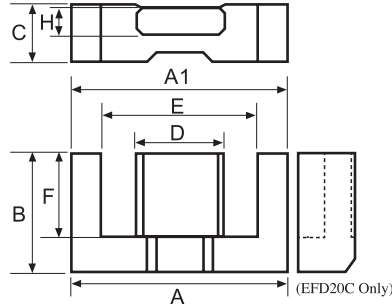

Type:4

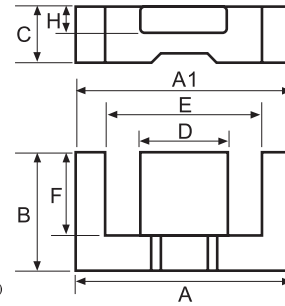

Type:5

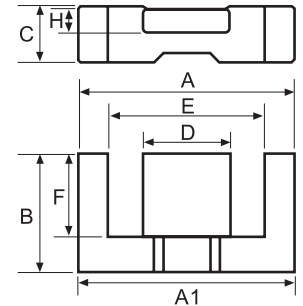

■ DIMENSIONS

CORES	DIMENSIONS (mm)								Type
	A	B	C	D	E	F	H	A-A1	
EFD20	20.00 ± 0.55	10.00 ± 0.15	6.65 ± 0.15	8.90 ± 0.20	15.40 ± 0.50	7.70 ± 0.25	3.60 ± 0.15	≤ 0.25mm	3
EFD20A	20.00 ± 0.55	11.60 ± 0.15	6.00 ± 0.15	8.90 ± 0.20	15.40 ^{+0.20} / _{-0.30}	9.30 ^{+0.25} / _{-0.20}	3.60 ± 0.15	≤ 0.20mm	3
EFD20B	20.00 ± 0.55	11.60 ± 0.15	5.40 ± 0.15	8.90 ± 0.20	15.40 ^{+0.20} / _{-0.30}	9.30 ^{+0.25} / _{-0.20}	3.60 ± 0.15	≤ 0.20mm	3
EFD20B/30	20.00 ± 0.55	15.00 ± 0.15	5.40 ± 0.15	8.90 ± 0.20	15.40 ^{+0.20} / _{-0.30}	12.70 ^{+0.25} / _{-0.20}	3.60 ± 0.15	≤ 0.20mm	3
EFD20C	20.00 ± 0.30	11.50 ± 0.15	5.60 ± 0.10	8.90 ± 0.20	15.40 ± 0.50	9.30 ± 0.15	3.60 ± 0.15	≤ 0.20mm	3
EFD20D	20.50 ± 0.40	10.00 ± 0.25	6.65 ^{+0.20} / _{-0.15}	8.90 ± 0.20	15.90 ± 0.30	7.70 ± 0.20	3.60 ± 0.15	≤ 0.20mm	3
EFD20E	20.00 ± 0.30	13.30 ± 0.20	5.80 ± 0.12	8.90 ± 0.20	15.40 ± 0.20	11.00 ± 0.20	3.50 ± 0.12	≤ 0.20mm	2
EFD20.3	20.30 ± 0.50	10.20 ± 0.15	6.00 ± 0.15	8.90 ± 0.20	15.70 ± 0.20	7.90 ± 0.20	3.60 ± 0.15	≤ 0.30mm	3
EFD20.6	20.60 ± 0.50	10.20 ± 0.15	6.60 ± 0.15	8.90 ± 0.20	16.70 ^{+0.40} / _{-0.20}	8.00 ± 0.15	3.70 ± 0.15	-	3
EFD20.7	20.70 ± 0.60	12.30 ± 0.20	4.15 ± 0.20	10.20 ± 0.25	15.80 ^{+0.50} / _{-0.30}	9.20 ± 0.20	2.05 ± 0.15	-	2
EFD21.4	21.40 ± 0.30	12.60 ± 0.20	6.00 ± 0.15	9.50 ± 0.15	16.10min	10.00 ± 0.20	3.40 ± 0.10	≤ 0.25mm	2
EFD21.5	21.50 ± 0.40	20.50 ± 0.20	4.65 ± 0.15	8.20 ± 0.15	14.20min	17.55 ± 0.15	2.90 ± 0.10	-	1
EFD22	22.00 ± 0.30	14.50 ± 0.15	7.40 ± 0.15	9.60 ± 0.15	16.00 ± 0.30	11.50 ± 0.15	4.20 ± 0.15	≤ 0.25mm	4
EFD22A	22.00 ± 0.50	16.30 ± 0.40	4.36 ± 0.25	10.00 ± 0.20	16.90 ± 0.50	13.90min	1.91 ± 0.15	0.30max	2
EFD22.5A	22.50 ± 0.60	12.00 ± 0.20	4.00 ± 0.20	11.00 ± 0.25	17.00 ± 0.40	9.35 ± 0.20	1.90 ± 0.15	-	2
EFD23.6	23.60 ± 0.40	14.40 ± 0.20	4.00 ± 0.20	11.00 ± 0.25	17.70min	11.60 ± 0.20	1.90 ± 0.20	-	2
EFD25	25.00 ± 0.65	12.50 ± 0.15	9.10 ± 0.20	11.40 ± 0.20	18.70 ± 0.60	9.30 ± 0.25	5.20 ± 0.15	≤ 0.30mm	3
EFD25A	25.05 ± 0.65	12.60 ± 0.20	12.45 ± 0.25	8.80 ± 0.25	19.20 ± 0.40	9.55 ± 0.25	8.30 ± 0.30	-	2
EFD25B	25.00 ± 0.65	12.50 ± 0.15	9.10 ± 0.20	11.40 ± 0.20	18.70 ± 0.60	9.30 ± 0.25	5.20 ± 0.15	-	3
EFD26.3	26.30 ± 0.50	12.70 ± 0.20	9.10 ± 0.20	11.30 ± 0.20	20.00min	9.50 ± 0.20	5.15 ± 0.15	-	5
EFD28.7	28.70 ± 0.40	14.90 ± 0.25	2.45 ± 0.10	14.80 ± 0.15	21.50 ± 0.35	11.30 ± 0.20	1.20 ± 0.10	≤ 0.30mm	2
EFD30	30.00 ± 0.80	15.00 ± 0.30	9.10 ± 0.30	14.60 ± 0.30	22.40 ± 0.75	11.20 ± 0.30	4.90 ± 0.25	-	1
EFD31	31.00 ± 0.45	18.00 ± 0.25	6.50 ± 0.20	14.00 ± 0.25	21.90 ± 0.40	13.50 ± 0.25	3.90 ± 0.20	-	2
EFD31.2	31.20 ± 0.50	15.25 ± 0.15	9.00 ± 0.20	14.40 ± 0.25	23.20 ± 0.40	11.30 ± 0.15	4.90 ± 0.15	-	3
EFD31.2B	31.20 ± 0.50	15.20 ± 0.20	9.00 ± 0.20	14.60 ± 0.30	23.80min	11.40 ± 0.20	4.90 ± 0.20	-	5
EFD31.4	31.40 ± 0.50	15.00 ± 0.20	9.10 ± 0.20	14.60 ± 0.25	23.40min	11.30 ± 0.20	4.90 ± 0.15	-	3
EFD31.4A	31.40 ± 0.60	15.50 ± 0.30	9.00 ± 0.20	14.60 ± 0.25	24.60min	11.70 ± 0.20	4.90 ± 0.20	-	5
FD31.8	31.80 ± 0.50	22.00 ± 0.15	5.10 ± 0.20	15.35 ± 0.40	21.60min	17.00 ± 0.15	3.15 ± 0.15	≤ 0.40mm	2



■ EFFECTIVE PARAMETERS

CORES	EFFECTIVE PARAMETERS				
	C _i (mm ⁻¹)	Le(mm)	Ae(mm ²)	Ve(mm ³)	Wt(g/set)
EFD20	1.59	45.49	28.50	1296.40	6.88
EFD20A	1.89	51.76	27.27	1411.49	7.66
EFD20B	2.00	51.46	25.64	1319.43	6.94
EFD20B/30	2.49	64.80	25.99	1684.15	8.92
EFD20C	1.98	51.22	25.84	1323.52	7.00
EFD20D	1.61	45.97	28.42	1306.40	6.90
EFD20E	2.19	58.48	26.65	1558.49	6.88
EFD20.3	1.72	46.02	27.88	1283.06	7.00
EFD20.6	1.78	47.40	26.59	1260.14	6.80
EFD20.7	2.53	52.78	20.84	1099.77	6.28
EFD21.4	1.88	55.76	29.66	1653.84	9.24
EFD21.5	3.16	84.57	26.75	2262.25	12.40
EFD22	1.57	62.52	39.94	2497.05	13.90
EFD22A	3.66	70.97	19.41	1377.87	7.67
EFD22.5A	2.53	54.00	21.30	1150.20	6.14
EFD23.6	3.02	63.32	20.97	1328.00	7.50
EFD25	1.03	55.81	53.92	3009.20	16.12
EFD25A	0.80	59.00	74.00	4370.00	22.40
EFD25B	1.04	55.81	53.92	3009.28	16.12
EFD26.3	1.05	57.80	54.83	3169.59	16.20
EFD28.7	4.03	65.02	16.10	1046.82	6.06
EFD30	0.98	66.02	67.52	4457.67	25.08
EFD31	1.44	77.23	53.56	4135.91	23.00
EFD31.2	0.99	67.85	68.52	4649.28	24.28
EFD31.2B	1.03	68.23	66.27	4521.52	25.24
EFD31.4	1.07	67.72	63.48	4298.64	25.40
EFD31.4A	1.11	69.62	62.71	4366.06	23.50
EFD31.8	1.91	91.32	47.77	4362.36	23.26

■ ELECTRICAL CHARACTERISTICS

CORES	AL ± 25% (nH/N ²)							AL + 40% - 30% (nH/N ²)			
	P4	P41	P46	P47	P48	P5	A05	A07	A10(L)	A121(L)	A151(L)
EFD20	1200 ± 30% 20%	1200 ± 30% 20%	1715	1600		1000		2800	5700 ± 30%	4500min	
EFD20A	1085										
EFD20B	1085										
EFD20B/30	950		1190				1640				
EFD20C	1085		1420								
EFD20D	1200	1160				1000		3000			
EFD20E	1200	1100									
EFD20.3	1150										
EFD20.6	1390										
EFD20.7	800										
EFD21.4	1300										
EFD21.5	960										
EFD22	1600	1550									
EFD22A	620										
EFD22.5A					950						
EFD23.6		850									
EFD25	2000 ± 30% 20%	1930	2780	2400		1600	4400	5480	9000 ± 30%		
EFD25A				3300 ± 30% 20%							
EFD25B				2400							
EFD26.3	2480										
EFD28.7	650										
EFD30				3150							
EFD31	1800										
EFD31.2	2700										
EFD31.2B	2150										
EFD31.4	2200										
EFD31.4A	2400										
EFD31.8	1500		1600								

Remark:

1. AL Value Testing Condition : 10kHz, 50mV, 100Ts. If testing condition is different from ACME's, please specify upon request & ordering.
2. Gapped core is available, please specify upon request & ordering. ACME's standard gapped core set is a combination of one gapped core and one ungapped core. If gapping on both pcs to make a set is needed, please specify upon request & ordering.
3. L : Mirror Finished Lapping. Please specify upon request & ordering by adding "L" at the end of Core Size if you need.

Type : EFD Cores (4)

Ordering Code:

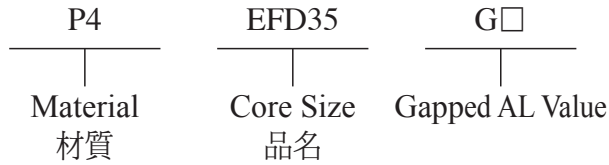

Shape:

Type:1

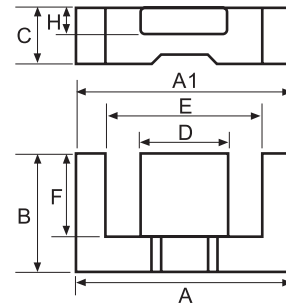

Type:2

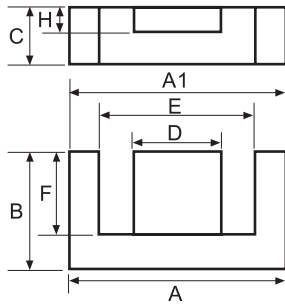

Type:3

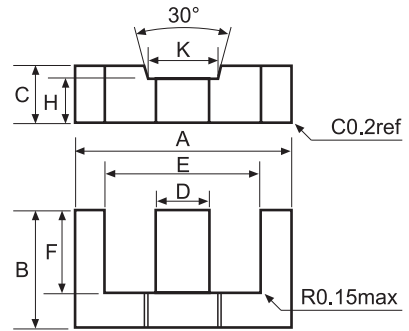

■ DIMENSIONS

CORES	DIMENSIONS (mm)								Type
	A	B	C	D	E	F	H	A-A1	
EFD33.7	33.70 ± 0.50	23.00 ± 0.15	5.00 ± 0.15	17.00 ± 0.20	23.70 ± 0.45	18.00 ± 0.15	3.00 ± 0.10	—	2
EFD35	35.00 ± 0.50	25.30 ± 0.20	5.70 ± 0.15	15.35 ± 0.25	24.70 ± 0.30	20.00 ± 0.20	3.80 ± 0.15	—	2
EFD35A	35.00 ± 0.50	13.90 ± 0.20	6.30 ± 0.25	18.00 ± 0.40	25.30min	9.50 ± 0.20	3.20 ± 0.20	—	1
EFD35.4	35.40 ± 0.50	25.60 ± 0.20	6.00 ± 0.20	15.30 ± 0.25	25.00min	20.30 ± 0.20	4.20 ± 0.15	—	2
EFD35.5	35.50 ± 0.80	17.75 ± 0.20	6.80 ± 0.20	16.20 ± 0.30	26.20 ± 0.60	13.10 ± 0.20	3.90 ± 0.15	—	2
EFD36	36.00 ± 0.50	18.90 ± 0.20	7.40 ± 0.15	17.60 ± 0.20	26.20 ± 0.50	13.80 ± 0.15	4.00 ± 0.15	—	2
EFD36.1	36.10 ± 0.55	17.80 ± 0.20	13.00 ± 0.30	10.00 ± 0.30	25.10min	12.80 ± 0.20	10.00 ± 0.30	—	3
EFD36.25	36.25 ± 0.50	24.00 ± 0.15	10.00 ± 0.20	14.00 ± 0.20	26.00min	19.00 ± 0.20	5.00 ± 0.20	—	2
EFD37.7	37.70 ± 0.50	17.60 ± 0.20	7.60 ± 0.20	18.60 ± 0.25	29.50 ^{+0.40} _{-0.30}	13.10 ± 0.15	3.40 ± 0.15	—	2
EFD37.7A	37.85 ± 0.65	17.60 ± 0.20	7.60 ± 0.20	18.60 ± 0.25	29.60min	13.10 ± 0.15	3.40 ± 0.15	—	2
EFD37.8	37.80 ± 0.50	29.00 ± 0.20	5.50 ± 0.20	13.80 ± 0.20	22.40 ± 0.45	21.60 ± 0.20	4.00 ± 0.15	—	2
EFD40.2	40.20 ± 0.50	24.70 ± 0.20	6.10 ± 0.20	20.00 ± 0.30	29.30 ± 0.60	18.00 ± 0.20	3.00 ± 0.15	—	2
EFD42.9	42.90 ± 0.70	24.40 ± 0.15	6.60 ± 0.15	21.60 ± 0.30	27.80min	17.00 ± 0.15	4.40 ± 0.15	—	2
EFD43	43.00 ± 0.60	26.30 ± 0.25	7.55 ± 0.20	21.60 ± 0.30	29.40 ± 0.60	18.80 ± 0.25	4.30 ± 0.20	—	2
EFD43.1	43.10 ± 0.65	22.15 ± 0.20	8.00 ± 0.15	22.30 ± 0.30	33.10 ^{+0.65} _{-0.30}	17.15 ± 0.20	3.50 ± 0.15	—	2
EFD43.4	43.40 ± 0.60	22.10 ± 0.20	8.00 ± 0.30	22.45 ± 0.25	33.50min	17.00 ± 0.20	3.20 ± 0.15	—	2
EFD43.7	43.70 ± 0.70	27.60 ± 0.15	6.20 ± 0.25	20.30 ± 0.30	29.50min	20.60 ± 0.15	4.00 ± 0.15	—	2
EFD43.7A	43.70 ± 0.70	28.50 ± 0.15	6.20 ± 0.25	20.30 ± 0.30	29.50min	21.50 ± 0.20	4.00 ± 0.15	—	2
EFD45	45.00 ± 0.50	27.60 ± 0.15	6.30 ± 0.15	21.60 ± 0.30	30.50 ± 0.50	20.20 ± 0.20	4.40 ± 0.15	—	2
EFD45.2	45.20 ± 0.65	24.70 ± 0.20	5.90 ± 0.15	24.00 ± 0.30	33.10 ^{+0.60} _{-0.40}	18.00 ± 0.20	3.00 ± 0.15	—	2
EFD47	47.00 ± 0.80	28.10 ± 0.20	8.70 ± 0.20	21.60 ± 0.40	30.60min	20.70 ± 0.20	6.50 ± 0.15	—	2
EFD50/56.4	50.00 ± 0.70	28.20 ± 0.30	6.20 ± 0.20	24.00 ± 0.30	34.40min	20.80 ± 0.20	3.20 ± 0.20	—	2
EFD64	64.00 ± 0.80	40.00 ± 0.20	6.60 ± 0.25	30.80 ± 0.40	39.00 ± 0.55	27.50 ± 0.20	4.40 ^{+0.10} _{-0.30}	—	2

■ EFFECTIVE PARAMETERS

CORES	EFFECTIVE PARAMETERS				
	C _l (mm ⁻¹)	Le(mm)	Ae(mm ²)	Ve(mm ³)	Wt(g/set)
EFD33.7	1.93	96.01	49.78	4779.38	25.06
EFD35	1.83	106.80	58.26	6222.27	32.64
EFD35A	1.11	61.68	55.32	3412.48	18.74
EFD35.4	1.74	108.31	32.33	6570.89	35.08
EFD35.5	1.28	78.47	61.19	4801.89	26.68
EFD36	1.16	81.57	70.26	5730.55	30.00
EFD36.1	0.70	81.02	116.48	9437.08	48.64
EFD36.25	1.27	102.80	80.78	8304.47	50.52
EFD37.7	1.39	79.59	57.29	4559.47	28.16
EFD37.7A	1.32	79.73	60.35	4811.71	27.50
EFD37.8	1.75	113.58	64.75	7354.31	43.80
EFD40.2	1.68	102.78	61.02	6271.50	37.60
EFD42.9	1.07	99.53	92.80	9236.38	50.80
EFD43	1.15	107.57	93.91	10102.30	58.66
EFD43.1	1.39	97.83	70.65	6911.83	41.94
EFD43.4	1.35	100.98	74.82	7555.32	40.60
EFD43.7	1.38	115.12	83.66	9630.94	53.04
EFD43.7A	1.49	119.23	80.04	9543.03	50.68
EFD45	1.23	114.05	92.97	10603.80	56.28
EFD45.2	1.56	104.87	67.15	7042.38	41.66
EFD47	0.84	116.84	138.72	16208.60	86.40
EFD50/56.4	1.45	119.73	82.47	9874.13	86.40
EFD64	1.10	157.65	143.80	22669.90	130.60

■ ELECTRICAL CHARACTERISTICS

CORES	AL ± 25% (nH/N ²)								AL + 40% - 30% (nH/N ²)		
	P4	P41	P46	P47	P48	P5	A05	A07	A10(L)	A121(L)	A151(L)
EFD33.7	1440										
EFD35	1600										
EFD35A		2300									
EFD35.4	1500										
EFD35.5					2100						
EFD36	1900										
EFD36.1	3400										
EFD36.25	2100										
EFD37.7				2280							
EFD37.7A					1900						
EFD37.8	1800										
EFD40.2	1650										
EFD42.9	2450										
EFD43	2300										
EFD43.1				2300							
EFD43.4					1800						
EFD43.7	1700										
EFD43.7A	1650										
EFD45	2200										
EFD45.2				1500							
EFD47	3400										
EFD50/56.4				2100							
EFD64	2950										

Remark:

1. AL Value Testing Condition : 10kHz, 50mV, 100Ts. If testing condition is different from ACME's, please specify upon request & ordering.
2. Gapped core is available, please specify upon request & ordering. ACME's standard gapped core set is a combination of one gapped core and one ungapped core. If gapping on both pcs to make a set is needed, please specify upon request & ordering.
3. L : Mirror Finished Lapping. Please specify upon request & ordering by adding "L" at the end of Core Size if you need.

Type : EPC Cores

Ordering Code:

P4	EPC19	G□
Material 材質	Core Size 品名	Gapped AL Value

Shape:

Type:1

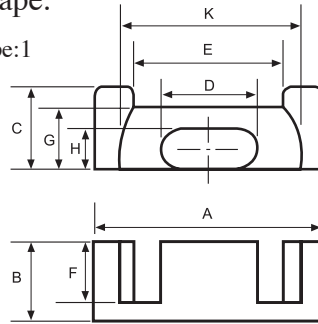

Type:2

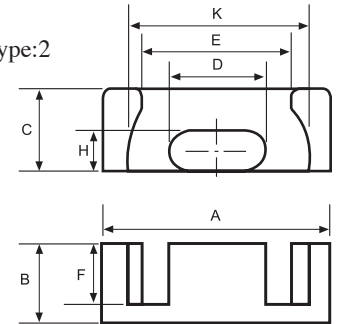

Type:3

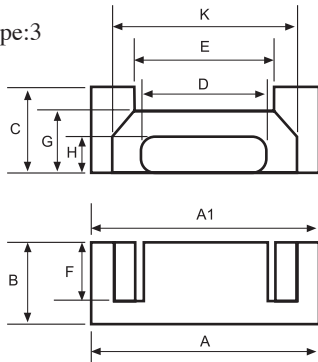

Type:4

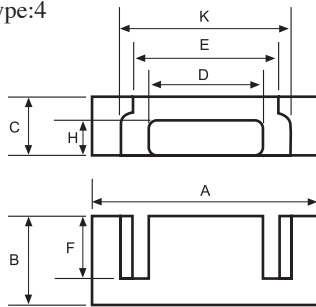

Type:5

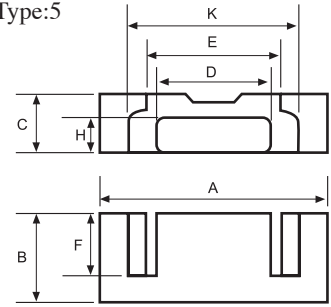

Type:6

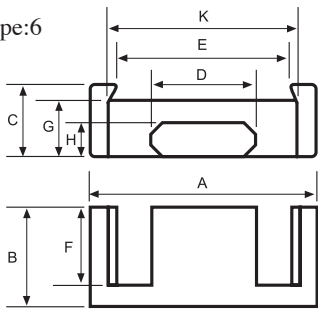

Type:7

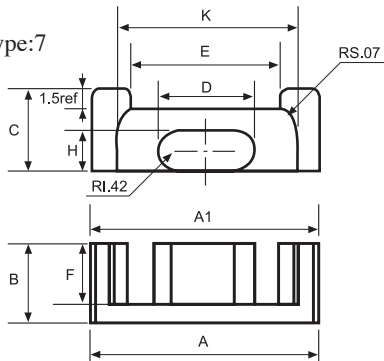

Type:8

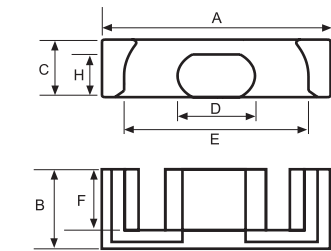

■ DIMENSIONS

CORES	DIMENSIONS (mm)									Type
	A	B	C	D	E	F	G	H	K	
EPC10	10.20 ± 0.30	4.05 ± 0.15	3.40 ± 0.15	5.00 ± 0.10	5.30min	2.55min	-	1.90 ± 0.10	7.60min	2
EPC10A	10.20 ± 0.30	4.05 ± 0.15	3.40 ± 0.15	5.00 ± 0.10	5.70min	2.55min	-	1.90 ± 0.10	7.90min	1
EPC12.6	12.40 ^{+0.40} / _{-0.00}	5.75 ^{+0.13} / _{-0.00}	3.60 ^{+0.00} / _{-0.25}	6.20 ^{+0.00} / _{-0.30}	7.32 ^{+0.30} / _{-0.00}	3.25 ^{+0.20} / _{-0.00}	-	2.30 ^{+0.00} / _{-0.18}	8.80 ^{+0.30} / _{-0.00}	2
EPC13A	13.50 ± 0.25	6.60 ± 0.20	4.60 ± 0.15	5.60 ± 0.15	8.50min	4.50 ± 0.20	-	2.05 ± 0.10	11.00 ± 0.20	1
EPC13C	13.30 ± 0.30	6.50 ± 0.20	4.40 ± 0.15	5.60 ± 0.15	9.00 ± 0.30	4.70 ± 0.20	-	2.05 ± 0.10	10.70 ± 0.20	2
EPC13D	13.20 ± 0.25	6.60 ± 0.20	4.60 ± 0.15	5.60 ± 0.15	8.70min	4.50 ± 0.20	-	2.05 ± 0.10	11min	1
EPC13F	13.10 ± 0.20	6.60 ± 0.20	4.40 ^{+0.10} / _{-0.15}	5.55 ± 0.15	8.30min	4.50 ± 0.20	3.65 ± 0.15	2.15 ^{+0.10} / _{-0.15}	10.60min	1
EPC14.5	14.50 ± 0.30	7.40 ± 0.20	6.00 ± 0.15	7.00 ± 0.15	10.10 ± 0.25	5.50 ± 0.15	-	3.20 ± 0.10	12.30 ± 0.30	2
EPC17A	17.60 ± 0.38	8.55 ± 0.20	6.00 ± 0.15	7.70 ± 0.15	11.50min	6.05 ± 0.20	-	2.75 ± 0.10	14.40min	1
EPC17B	17.60 ± 0.30	8.55 ± 0.20	6.05 ± 0.15	7.60 ± 0.20	12.00min	6.25 ± 0.20	-	2.85 ± 0.15	14.50min	7
EPC18	18.40 ± 0.30	13.20 ± 0.15	4.10 ± 0.15	9.10 ± 0.15	10.70min	10.30 ± 0.15	-	2.65 ± 0.10	13.10min	1
EPC19/10	19.10 ± 0.40	10.00 ± 0.20	6.00 ± 0.15	8.50 ± 0.15	13.10min	7.50 ^{+0.20} / _{-0.10}	-	2.50 ± 0.10	15.80min	1
EPC19A	19.60 ± 0.50	9.75 ± 0.20	6.00 ± 0.20	8.20 ± 0.20	13.60 ± 0.50	7.25 ± 0.20	-	2.40 ± 0.15	16.40 ± 0.50	1
EPC19B	19.60 ± 0.50	9.75 ± 0.20	6.00 ± 0.20	8.20 ± 0.20	13.40 ± 0.50	7.25 ± 0.20	-	2.40 ± 0.15	16.40 ± 0.50	1
EPC19.5	19.50 ± 0.40	10.90 ± 0.20	6.00 ± 0.15	8.50 ± 0.15	13.40min	8.40 ± 0.15	4.60 ± 0.15	2.40 ± 0.10	16.20min	3
EPC19.6	19.60 ± 0.40	12.34 ± 0.25	4.12 ± 0.10	10.02 ± 0.15	14.50 ± 0.35	9.25 ± 0.20	-	2.03 ± 0.10	15.75 ± 0.35	4
EPC20	20.00 ± 0.40	12.34 ± 0.25	4.12 ± 0.15	10.02 ± 0.15	14.90 ± 0.35	9.25 ± 0.20	-	2.03 ± 0.15	16.15 ± 0.35	4
EPC21.9	21.90 ± 0.30	14.50 ± 0.20	7.30 ± 0.15	9.50 ± 0.15	14.70min	11.55 ± 0.15	-	4.20 ± 0.15	16.40min	5
EPC24.8	24.80 ± 0.40	12.80 ± 0.15	8.90 ± 0.15	8.40 ± 0.20	20.1 ± 0.30	9.60 ± 0.15	-	6.60 ± 0.15	-	8
EPC25	25.40 ± 0.50	12.50 ± 0.25	8.00 ± 0.25	10.50 ± 0.25	18.35 ± 0.40	9.00 ± 0.20	6.20ref	4.00 ± 0.20	21.05 ± 0.40	6



■ EFFECTIVE PARAMETERS

CORES	EFFECTIVE PARAMETERS				
	C _l (mm ⁻¹)	Le(mm)	Ae(mm ²)	Ve(mm ³)	Wt(g/set)
EPC10	2.03	19.28	8.36	161.23	0.92
EPC10A	2.18	18.73	8.61	161.27	0.88
EPC12.6	1.56	22.51	14.42	324.59	1.44
EPC13A	2.55	31.08	12.18	378.55	2.12
EPC13C	2.56	29.91	11.69	349.65	2.20
EPC13D	2.38	29.29	12.33	361.10	2.00
EPC13F	2.28	28.92	12.68	366.80	1.80
EPC14.5	1.97	24.38	12.39	301.97	1.73
EPC17A	1.76	38.87	22.07	857.90	4.72
EPC17B	1.85	40.00	21.60	864.00	4.72
EPC18	2.49	55.11	22.09	1217.38	6.36
EPC19/10	2.07	47.12	22.72	1070.56	5.36
EPC19A	1.88	43.30	23.00	995.90	5.38
EPC19B	2.26	49.38	21.89	1080.93	5.30
EPC19.5	1.94	41.99	21.64	908.69	5.90
EPC19.6	2.95	52.33	17.70	926.24	5.42
EPC20	2.89	53.24	18.40	979.62	5.52
EPC21.9	1.71	63.15	36.90	2330.24	12.84
EPC24.8	1.22	60.34	49.24	2970.86	15.50
EPC25	1.39	58.64	42.31	2481.06	12.16

■ ELECTRICAL CHARACTERISTICS

CORES	AL ± 25% (nH/N ²)								AL ± 30% (nH/N ²)		
	P4	P41	P46	P47	P48	P5	A05	A07	A10(L)	A121(L)	A151(L)
EPC10	820	800	980	900		720		1180			
EPC10A	950			970				1400			
EPC12.6	1000					800					
EPC13A	910	890	955	900		770			3240		
EPC13C								1420			
EPC13D	800										
EPC13F	820										
EPC14.5	1200										
EPC17A		1300									
EPC17B	1150										
EPC18	1000										
EPC19/10	930										
EPC19A	1100		1500			930					
EPC19B	1100										
EPC19.5	1040										
EPC19.6	860										
EPC20	820										
EPC21.9	1390										
EPC24.8				2000							
EPC25	1550	1500	2300			1290					

Remark:

1. AL Value Testing Condition : 10kHz, 50mV, 100Ts. If testing condition is different from ACME's, please specify upon request & ordering.
2. Gapped core is available, please specify upon request & ordering. ACME's standard gapped core set is a combination of one gapped core and one ungapped core. If gapping on both pcs to make a set is needed, please specify upon request & ordering.
3. L : Mirror Finished Lapping. Please specify upon request & ordering by adding "L" at the end of Core Size if you need.

■ EFFECTIVE PARAMETERS

CORES	EFFECTIVE PARAMETERS				
	C _i (mm ⁻¹)	Le(mm)	Ae(mm ²)	Ve(mm ³)	Wt(g/set)
CI4.4/4.0/1.35/0.9	1.89	7.70	4.07	31.32	0.18
CI5.6/5.65/2.9/2.0	1.00	11.37	11.33	128.84	0.67
CI6.0/3.6/1.2/0.95	3.11	11.07	3.56	39.37	0.20
CI6.35/6.35	1.01	12.69	12.60	159.89	0.81
CI6.35/6.35A	1.51	11.20	7.40	82.88	0.48
CI6.6/6.1	1.03	12.33	11.96	147.54	0.83
CI6.6/6.8/2.65/2	0.96	12.90	13.48	173.89	0.91
CI6.6/9.1	0.67	12.23	18.19	222.46	1.26
CI6.6/9.1A	0.63	14.06	22.20	312.13	1.26
CI6.6A/6.1/2.55/1.8	1.04	12.38	11.88	147.10	0.84
CI6.6B/6.0/2.25/2.24	1.01	12.36	12.20	150.83	0.79
CI6.6D/9.1/2.25/2.24	0.67	12.36	18.51	228.76	1.19
CI6.6F/6.8/2.65/2.1	0.94	13.02	13.81	179.79	0.94
CI6.7/6.7/3.6/3	0.78	13.87	17.69	245.38	1.32
CI6.8B/6.8/2.45/1.9	0.88	12.21	13.92	169.98	0.95
CI6.85A/9.2/2.2/1.65	0.73	12.08	16.48	199.11	1.20

■ DIMENSIONS

CORES	DIMENSIONS (mm)							Type
	F	G	H	J	A1	C1	I	
CI4.4/4.0/1.35/0.9	0.35 ± 0.08	–	–	–	4.40 ± 0.15	4.00 ± 0.15	0.90 ± 0.05	4
CI5.6/5.65/2.9/2.0	0.60 ± 0.10	0.15 ± 0.10	4.95 ± 0.15	–	5.60 ± 0.15	5.65 ± 0.15	2.00 ± 0.05	5
CI6.0/3.6/1.2/0.95	0.25 ± 0.08	–	–	–	6.00 ± 0.20	3.60 ± 0.20	0.95 ± 0.05	4
CI6.35/6.35	0.35 ± 0.10	0.22 ± 0.05	–	1.40 ± 0.10	6.35 ± 0.13	6.35 ± 0.13	2.27 ± 0.10	2
CI6.35/6.35A	0.40 ^{+0.10} _{-0.07}	0.25 ± 0.05	–	1.60 ± 0.10	6.35 ± 0.10	6.35 ± 0.10	1.10 ± 0.10	2
CI6.6/6.1	0.51 ± 0.10	0.25 ± 0.10	–	–	6.71 ± 0.15	6.20 ± 0.15	1.86 ± 0.10	1
CI6.6/6.8/2.65/2	0.50 ± 0.10	0.15 ± 0.10	6.15 ± 0.20	–	6.60 ± 0.20	6.80 ± 0.20	2.00 ± 0.10	1
CI6.6/9.1	0.51 ± 0.10	0.25 ± 0.10	–	–	6.71 ± 0.15	9.15 ± 0.15	1.86 ± 0.10	1
CI6.6/9.1A	0.61 ^{+0.10} _{-0.07}	0.25 ± 0.10	–	–	6.71 ± 0.15	9.15 ± 0.15	2.50 ± 0.20	1
CI6.6A/6.1/2.55/1.8	0.51 ± 0.10	0.25 ± 0.10	–	–	6.71 ± 0.15	6.20 ± 0.15	1.80 ± 0.10	6
CI6.6B/6.0/2.25/2.24	0.40 ± 0.10	0.24 ± 0.10	–	–	6.60 ± 0.15	6.00 ± 0.15	2.24 ± 0.10	7
CI6.6D/9.1/2.25/2.24	0.40 ± 0.10	0.24 ± 0.10	–	–	6.60 ± 0.15	9.10 ± 0.15	2.24 ± 0.10	7
CI6.6F/6.8/2.65/2.1	0.50 ± 0.10	0.20 ± 0.10	6.20 ± 0.20	–	6.60 ± 0.20	6.80 ± 0.20	2.10 ± 0.10	8
CI6.7/6.7/3.6/3	0.70 ± 0.10	0.35 ± 0.10	5.80 ± 0.15	–	6.70 ± 0.15	6.70 ± 0.15	3.00 ± 0.05	1
CI6.8B/6.8/2.45/1.9	0.35 ± 0.10	0.10 ± 0.10	6.00 ± 0.15	–	6.80 ± 0.15	6.80 ± 0.15	1.90 ± 0.05	9
CI6.85A/9.2/2.2/1.65	0.55 ± 0.10	–	–	–	6.85 ± 0.15	9.20 ± 0.20	1.65 ± 0.05	4

■ EFFECTIVE PARAMETERS

CORES	EFFECTIVE PARAMETERS				
	C _i (mm ⁻¹)	Le(mm)	Ae(mm ²)	Ve(mm ³)	Wt(g/set)
CI7.0/9.8/4.5/2.2	0.53	13.64	25.98	354.34	2.07
CI7.0/9.9/3.6/2.95	0.53	14.18	26.99	382.83	2.09
CI7.0B/3.6/1.35/0.95	3.92	13.79	3.52	48.57	0.25
CI7.1B/9.95/4.2/2.4	0.56	14.75	26.12	385.48	2.17
CI7.2A/10.2/4.75/3.75	0.43	14.91	34.34	512.16	3.03
CI7.5/13.3/2.05/1.45	0.65	14.10	21.80	307.51	1.51
CI7.5A/9.0/3.8/3.2	0.58	15.09	26.05	393.24	2.21
CI7.5B/9.5/3.0/3.0	0.54	13.99	25.72	359.89	2.04
CI8.7/9.4/5.3/4.3	0.44	16.79	38.25	642.19	3.80
CI9.6/11.7/2.9/2.5	0.57	17.24	30.30	522.43	2.80
CI9.9/10.52/4.57/3.81	0.47	18.40	38.78	713.55	4.03
CI10/10/5.2/3.6	0.54	19.72	36.57	721.16	3.87
CI10.52/10.52	0.54	21.74	40.00	869.60	4.40
CI10.7/9.7	0.51	19.26	37.90	729.95	4.11
CI12.68/12.68	0.61	23.84	43.19	1029.64	5.38
CI12.7/13/4.57/3.81	0.40	21.52	53.48	1150.89	6.43
CI12.7D/12.7/3.6/3.7	0.51	22.62	44.68	1010.76	5.18
CI13/12.5/5.2/3.6	0.45	22.82	50.59	1154.46	6.53

■ DIMENSIONS

CORES	DIMENSIONS (mm)							Type
	F	G	H	J	A1	C1	I	
CI7.0/9.8/4.5/2.2	0.80 ± 0.07	0.65 ± 0.07	9.00 ± 0.15	-	7.00 ± 0.15	9.80 ± 0.15	2.20 ± 0.10	3
CI7.0/9.9/3.6/2.95	0.50 ± 0.10	0.15 ± 0.08	-	-	7.00 ± 0.15	10.00 ± 0.15	2.95 ± 0.10	1
CI7.0B/3.6/1.35/0.95	0.35 ± 0.10	-	-	-	7.00 ± 0.20	3.60 ± 0.20	0.95 ± 0.05	4
CI7.1B/9.95/4.2/2.4	0.85 ± 0.07	0.35 ± 0.07	0.80 ± 0.15	-	7.15 ± 0.13	10.00 ± 0.13	2.40 ± 0.10	10
CI7.2A/10.2/4.75/3.75	1.08 ± 0.10	-	-	-	7.20 ± 0.15	10.20 ± 0.15	3.75 ± 0.05	11
CI7.5/13.3/2.05/1.45	0.37 ± 0.10	0.20 ± 0.10	12.70 ± 0.12	-	7.50 ± 0.15	13.30 ± 0.20	1.45 ± 0.05	9
CI7.5A/9.0/3.8/3.2	0.70 ± 0.10	0.40 ± 0.10	-	-	7.50 ± 0.15	9.00 ± 0.15	3.20 ± 0.10	7
CI7.5B/9.5/3.0/3.0	0.40 ± 0.10	0.20 ± 0.10	-	-	7.50 ± 0.15	9.50 ± 0.15	3.00 ± 0.10	7
CI8.7/9.4/5.3/4.3	1.00 ± 0.10	-	-	-	8.70 ± 0.15	9.40 ± 0.15	4.30 ± 0.05	11
CI9.6/11.7/2.9/2.5	0.30 ± 0.10	0.10 ± 0.08	11.00 ± 0.20	-	9.60 ± 0.15	11.70 ± 0.20	2.50 ± 0.05	9
CI9.9/10.52/4.57/3.81	0.70 ± 0.10	0.25 ± 0.10	10.00 ± 0.15	-	9.90 ± 0.20	10.52 ± 0.20	3.81 ± 0.05	1
CI10/10/5.2/3.6	1.15 ± 0.10	0.65 ± 0.10	1.80 ± 0.15	-	10.00 ± 0.15	10.00 ± 0.15	3.60 ± 0.10	12
CI10.52/10.52	0.55 ± 0.05	0.25 ± 0.05	-	-	10.82 ± 0.20	10.82 ± 0.20	3.81 ± 0.05	1
CI10.7/9.7	0.70 ^{+0.10} _{-0.07}	0.25 ± 0.05	-	-	10.75 ± 0.20	9.75 ± 0.20	3.80 ± 0.10	1
CI12.68/12.68	0.69 ± 0.10	0.15 ± 0.10	12.29 ± 0.15	-	12.68 ± 0.15	12.68 ± 0.15	3.38 ± 0.08	1
CI12.7/13/4.57/3.81	0.65 ± 0.10	0.25 ± 0.10	12.50 ± 0.20	-	12.70 ± 0.20	13.00 ± 0.20	3.81 ± 0.10	1
CI12.7D/12.7/3.6/3.7	0.40 ± 0.10	0.20 ± 0.10	-	-	12.70 ± 0.15	12.70 ± 0.15	3.70 ± 0.10	7
CI13/12.5/5.2/3.6	1.20 ± 0.10	0.50 ± 0.10	1.60 ± 0.15	-	13.00 ± 0.15	12.5 ± 0.15	3.60 ± 0.10	12

Type : DR Cores

Ordering Code:

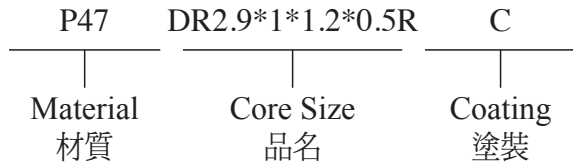

Shape:

Type:1

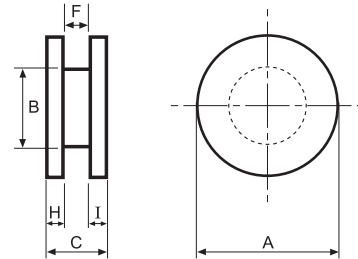

R : Slot, 出線槽

C : Black Epoxy Coating of Halogen-Free

D3 : Shape with different flange size, 上下擺外徑不同

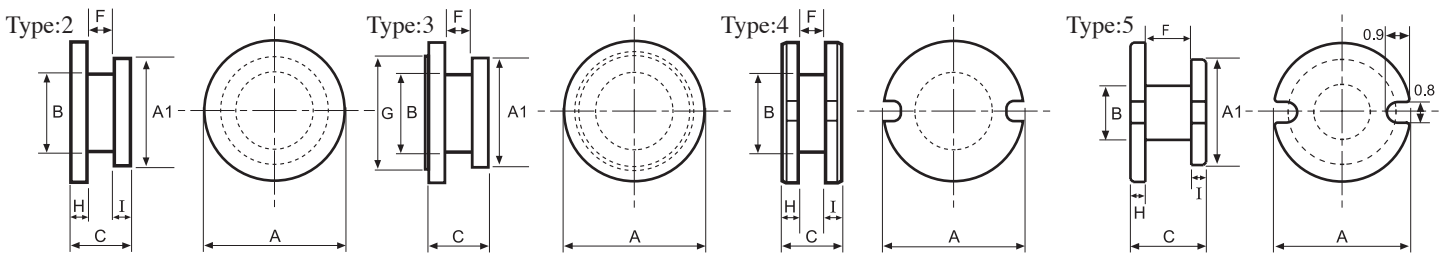

■ DIMENSIONS

CORES	DIMENSIONS (mm)							Wt(g/set)	Type
	COATING DIMENSIONS (mm)								
	A	A1	B	C	F	H	I		
DR2.2x0.6x0.8x0.3	2.20 ± 0.10	-	0.80 ± 0.05	0.60 ± 0.05	0.30 ± 0.05	0.15 ± 0.05	0.15 ± 0.05	0.006	1
DR2.2x0.85x0.9x0.25	2.20 ± 0.10	-	0.90 ± 0.05	0.85 ± 0.05	0.25 ± 0.05	0.30 ± 0.05	0.30 ± 0.05	0.012	1
DR2.2x1.25x1x0.65	2.20 ± 0.10	-	1.00 ± 0.10	1.25 ± 0.10	0.65 ± 0.05	0.30 ± 0.05	0.30 ± 0.05	0.014	1
DR2.2x2.7x1.5x1.5R	2.20 ± 0.10	-	1.50 ± 0.10	2.70 ± 0.10	1.50 ± 0.05	0.60 ± 0.05	0.60 ± 0.05	0.035	4
DR2.9x1x1.2x0.5R	2.90 ± 0.10	-	1.20 ± 0.10	1.00 ± 0.10	0.50 ± 0.05	0.25 ± 0.05	0.25 ± 0.05	0.02	4
DR2.9x1.6x1.4x0.9R	2.90 ± 0.10	-	1.40 ± 0.10	1.60 ± 0.10	0.90 ± 0.10	0.35 ± 0.05	0.35 ± 0.05	0.03	4
DR2.9x1.8x1.2x1.1	2.90 ± 0.10	-	1.20 ± 0.10	1.80 ± 0.10	1.10 ± 0.10	0.35 ± 0.05	0.35 ± 0.05	0.03	1
DR3.2x1.6x1.4x0.9R	3.20 ± 0.05	-	2.20 ± 0.05	1.60 ± 0.05	0.90 ± 0.05	0.35 ± 0.05	0.35 ± 0.05	0.04	4
DR3.8x0.8x1.5x0.3R	3.80 ± 0.10	-	1.50 ± 0.10	0.80 ± 0.05	0.30 ± 0.05	0.25 ± 0.05	0.25 ± 0.05	0.03	4
DR3.8x1.25x1.65x0.65R	3.80 ± 0.10	-	1.65 ± 0.10	1.25 ± 0.10	0.65 ± 0.05	0.30 ± 0.05	0.30 ± 0.05	0.04	4
DR3.8x2.15x1.5x1.2	3.80 ± 0.07	-	1.50 ± 0.10	2.15 ± 0.07	1.20 ± 0.05	0.48 ± 0.05	0.48 ± 0.05	0.07	1
	3.90 ± 0.15	-	1.56 ± 0.15	2.25 ± 0.15	1.12 ± 0.10	0.57 ± 0.10	0.57 ± 0.10		
DR4.2x0.9x2.2x0.4R	4.20 ^{+0.00} / _{-0.10}	-	2.20 ± 0.08	0.90 ± 0.05	0.40 ± 0.15	0.25 ± 0.05	0.40 ± 0.05	0.04	4
DR4.6x2.25x2.3x1.35R	4.60 ± 0.10	-	2.30 ± 0.10	2.25 ± 0.05	1.35 ± 0.10	0.45 ± 0.05	0.45 ± 0.05	0.09	4
DR5x1.1x1.4x0.5D3	5.00 ± 0.10	3.95 ± 0.07	1.40 ± 0.10	1.05 ^{+0.02} / _{-0.08}	0.50 ± 0.10	0.30 ± 0.05	0.25 ± 0.05	0.06	2
DR5.05x3x1.9x2.1D3	5.05 ± 0.10	3.80 ± 0.10	1.90 ± 0.10	3.00 ± 0.10	2.10 ± 0.08	0.45 ± 0.08	0.45 ± 0.08	0.16	5
	5.15 ± 0.15	3.90 ± 0.15	2.00 ± 0.10	3.10 ± 0.10	2.00 ± 0.10	0.55 ± 0.10	0.55 ± 0.10		
DR5.3x2x2.5x1.2	5.30 ± 0.10	-	2.50 ± 0.10	2.00 ± 0.10	1.20 ± 0.10	0.40 (Ref)	0.40 (Ref)	0.12	1
DR5.4x2.95x2.7x1.55	5.10 ± 0.15	-	2.55 ± 0.15	2.80 ± 0.15	1.64 ± 0.15	0.58 ± 0.15	-	0.16	1
	5.40 ± 0.20	-	2.70 ± 0.15	2.95 ± 0.20	1.55 ± 0.15	0.70 ± 0.15	-		
DR5.4x4.2x2.7x2.7R	5.30 ± 0.10	-	2.65 ± 0.10	4.10 ± 0.07	2.75 ± 0.10	0.67 ± 0.07	-	0.22	4
	5.40 ± 0.15	-	2.70 ± 0.10	4.20 ± 0.10	2.70 ± 0.10	0.75 ± 0.10	-		
DR5.4x5.7x3.2x4.2R	5.30 ± 0.10	-	3.15 ± 0.10	5.65 ± 0.07	4.25 ± 0.10	0.67 ± 0.07	-	0.29	4
	5.40 ± 0.15	-	3.20 ± 0.10	5.70 ± 0.10	4.20 ± 0.10	0.75 ± 0.10	-		
DR7.8x3.2x3.4x1.6R	7.70 ± 0.15	-	3.32 ± 0.10	3.10 ± 0.06	1.70 ± 0.10	0.70 ± 0.05	-	0.38	4
	7.80 ± 0.15	-	3.40 ± 0.10	3.20 ^{+0.05} / _{-0.10}	1.60 ± 0.10	0.77 ± 0.07	-		
DR7.8x3.7x3.75x2.04R	7.70 ± 0.15	-	3.67 ± 0.10	3.60 ± 0.05	2.10 ± 0.10	0.75 ± 0.10	0.75 ± 0.10	0.45	4
	7.80 ± 0.15	-	3.75 ± 0.10	3.70 ^{+0.05} / _{-0.10}	2.04 ± 0.10	0.83 ± 0.10	-		

Remark: Black epoxy Coating, breakdown Voltage : 500Vdc.

Type : DR Cores

Ordering Code:

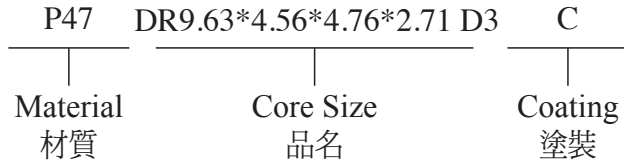

Shape:

Type:1

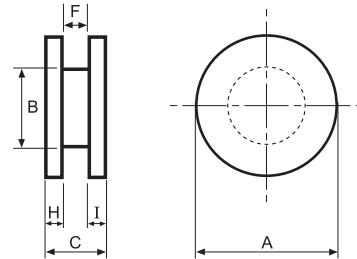

R : Slot, 出線槽

C : Epoxy Coating of Halogen-Free

D3 : Shape with different flange size, 上下擺外徑不同

Type:2

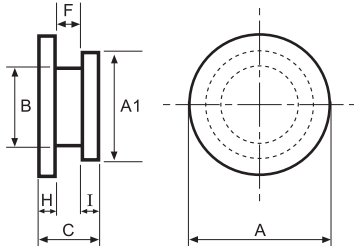

Type:3

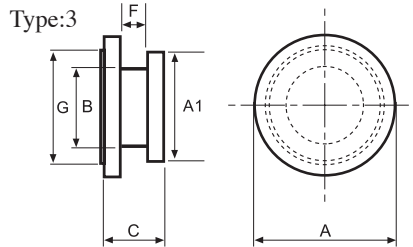

Type:4

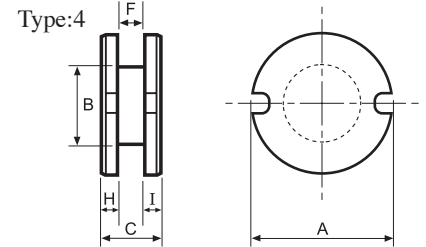

■ DIMENSIONS

CORES	DIMENSIONS (mm)								Wt(g/set)	Type
	COATING DIMENSIONS (mm)									
	A	A1	B	C	F	H	I	G		
DR8.2x4.1x3.0x2.5	8.20 ± 0.15	-	3.00 ± 0.15	4.10 ± 0.15	2.50 ± 0.10	0.80 ± 0.10	0.80 ± 0.10	-	0.50	1
	8.30 ± 0.20	-	3.10 ± 0.20	4.20 ± 0.20	2.42 ± 0.15	0.90 ± 0.15	0.90 ± 0.15	-		
DR8.38x4.2x3.1x2.65	8.20 ± 0.25	-	3.10 ± 0.25	4.00 ± 0.20	2.65 ± 0.20	0.68 ± 0.15	-	-	0.52	1
	9.05max	-	3.95max	4.80max	1.85min	-	-	-		
DR8.38x10.2x4.4x8.05	8.20 ± 0.15	-	4.40 ± 0.15	10.00 ± 0.15	8.05 ± 0.15	0.95 ± 0.15	-	-	1.15	1
	8.95max	-	5.15max	10.75max	7.30min	-	-	-		
DR9.5x6.4x4.95x4.6	9.50 ± 0.15	-	4.95 ± 0.10	6.40 ± 0.15	4.60 ± 0.10	0.90 ± 0.10	0.90 ± 0.10	-	1.04	1
	9.60 ± 0.20	-	5.05 ± 0.15	6.50 ± 0.20	4.50 ± 0.15	1.00 ± 0.15	1.00 ± 0.15	-		
DR9.6x7.3x6.0x5.05R	9.45 ± 0.15	-	5.85 ± 0.15	7.17 ± 0.15	5.20 ± 0.15	0.99 ± 0.15	-	-	1.30	4
DR9.63x4.56x4.76x2.71D3	9.63 ± 0.15	7.56 ± 0.15	4.76 ± 0.15	4.56 ± 0.15	3.00 ± 0.20	-	-	6.66 ± 0.15	0.74	3
	9.77 ± 0.17	7.70 ± 0.20	4.90 ± 0.20	4.70 ± 0.20	2.85 ± 0.25	-	-	6.80 ± 0.25		
DR9.8x3.85x4.8x2.15D3	9.65 ± 0.15	7.45 ± 0.15	4.70 ± 0.15	3.75 ± 0.15	2.10 ± 0.15	0.87 ± 0.10	0.78 ± 0.10	-	0.69	2
	9.80 ± 0.15	7.60 ± 0.15	4.80 ± 0.15	3.85 ± 0.15	2.05 ± 0.15	0.95 ± 0.10	0.85 ± 0.10	-		
DR9.8x5.8x4.95x3.95	9.50 ± 0.20	-	4.95 ± 0.25	5.80 ± 0.10	3.95 ± 0.20	-	-	-	1.07	1
	10.30max	-	5.80max	6.20max	3.50min	-	-	-		
DR10.85x5.2x5.1x3.2	10.90 ± 0.15	-	5.10 ± 0.15	5.20 ± 0.15	3.20 ± 0.15	1.00 ± 0.10	1.00 ± 0.10	-	1.20	1
	11.00 ± 0.20	-	5.20 ± 0.15	5.30 ± 0.15	3.10 ± 0.15	1.10 ± 0.15	1.10 ± 0.15	-		
DR12x7x6.2x4	11.85 ± ^{0.20} _{-0.10}	-	6.10 ± 0.10	6.90 ± ^{0.15} _{-0.10}	4.10 ± ^{0.10} _{-0.15}	1.40 ± 0.10	1.40 ± 0.10	-	1.99	1
	12.00 ± 0.15	-	6.20 ± 0.15	7.00 ± 0.15	4.00 ± 0.15	1.50 ± 0.15	1.50 ± 0.15	-		
DR12.7x5.8x6.2x3.5	12.70 ± 0.20	-	6.20 ± 0.15	5.80 ± 0.15	3.50 ± 0.15	1.15 ± 0.10	1.15 ± 0.10	-	1.90	1
	12.80 ± 0.20	-	6.30 ± 0.20	6.20max	3.40 ± 0.15	1.25 ± 0.15	1.25 ± 0.15	-		
DR12.7x6x6.2x3.5	12.70 ± 0.20	-	6.20 ± 0.20	5.80 ± 0.20	3.50 ± 0.15	-	-	-	1.80	1
	13.50max	-	7.00max	6.70max	2.75min	-	-	-		
DR14.85x6.8x7x4.5	14.85 ± 0.15	-	7.00 ± 0.15	6.80 ± 0.15	4.50 ± 0.15	1.15 ± 0.15	1.15 ± 0.15	-	2.75	1
	15.00 ± 0.15	-	7.10 ± 0.15	6.90 ± 0.15	4.40 ± 0.15	1.25 ± 0.15	1.25 ± 0.15	-		
DR16.4x4.8x8x2.7	16.36 ± 0.15	-	7.90 ± 0.10	4.80 ± 0.15	2.70 ± 0.10	1.05 ± 0.10	1.05 ± 0.10	-	2.76	1
	16.50 ± 0.20	-	8.00 ± 0.15	4.90 ± 0.20	2.60 ± 0.15	1.15 ± 0.15	1.15 ± 0.15	-		

Remark: Black epoxy Coating, breakdown Voltage : 500Vdc.

Type : R Cores

Ordering Code:

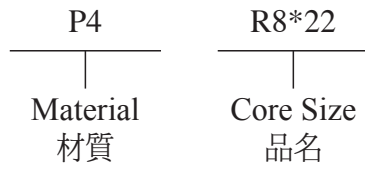

Shape:

Type:1

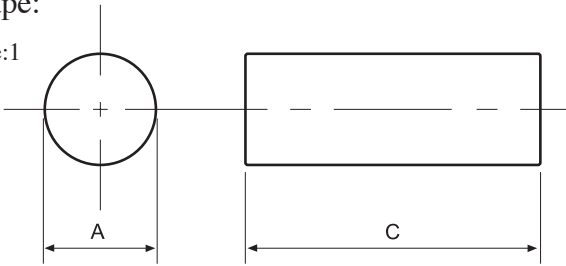

Type:2

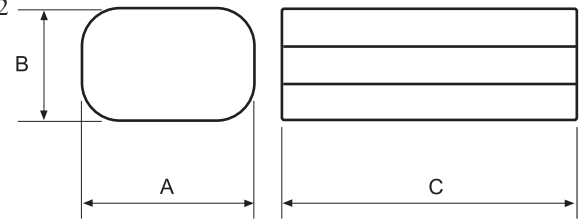

Type:3

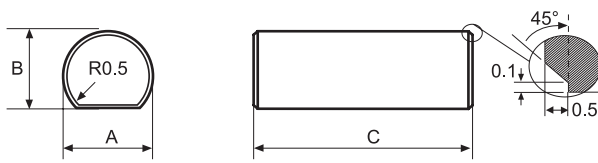

Type:4

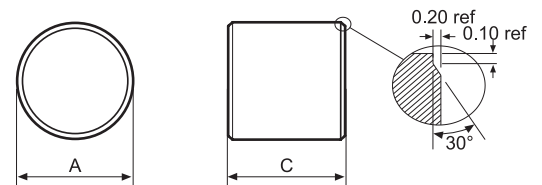

■ DIMENSIONS

CORES	DIMENSIONS (mm)			EFFECTIVE PARAMETERS					Type
	A	B	C	C _i (mm ⁻¹)	Le(mm)	Ae(mm ²)	Ve(mm ³)	Wt(g/set)	
R1.16x7.1	1.16 ± 0.02	—	7.10 ± 0.10	6.72	7.10	1.06	7.50	0.04	1
R1.7x18	1.70 ± 0.15	—	18.00 ± 0.50	7.93	18.00	2.27	40.86	0.18	1
R2.5x18	2.50 ± 0.20	—	18.00 ± 0.50	3.67	18.00	4.91	88.38	0.40	1
R3x19	3.00 ± 0.20	—	19.00 ± 0.20	2.69	19.00	7.07	134.30	0.65	1
R3.5x5.4	3.50 ± 0.10	—	5.40 ^{+0.10} / _{-0.05}	0.56	5.40	9.62	51.95	0.21	1
R4x5	4.00 ± 0.10	—	5.00 ^{+0.10} / _{-0.05}	0.40	5.00	12.57	62.83	0.30	1
R4.2x6.1	4.20 ± 0.10	—	6.10 ± 0.10	4.54	3.05	13.85	42.23	0.80	1
R4.3x7	4.30 ± 0.10	—	7.00 ± 0.10	0.48	7.00	14.52	101.65	0.64	1
R4.5x5.8	4.50 ^{+0.05} / _{-0.10}	—	5.80 ± 0.10	0.36	5.80	15.90	92.25	0.50	1
R5x3.6x8	5.00 ± 0.15	3.60 ± 0.15	8.00 ± 0.15	0.58	10.56	18.07	190.83	0.50	2
R5x7	5.00 ± 0.10	—	7.00 ± 0.10	0.36	7.00	19.63	137.44	0.51	1
R5Bx30	5.00 ^{+0.00} / _{-0.30}	—	30.00 ± 1.00	1.62	30.00	18.47	554.10	2.63	1
R5.5x7.9	5.50 ± 0.10	—	7.90 ^{+0.05} / _{-0.15}	0.33	7.90	23.76	187.70	0.93	1
R5.8x5.2	5.80 ± 0.10	—	5.20 ± 0.10	0.20	5.20	26.42	137.00	0.65	1
R5.9x5.8	5.90 ± 0.10	—	5.80 ^{+0.00} / _{-0.10}	4.71	5.80	27.34	158.57	0.75	1
R6x15	6.00 ± 0.15	—	15.00 ± 0.20	3.77	7.50	28.26	211.95	4.06	1
R6.5x8.2	6.50 ± 0.15	—	8.20 ± 0.20	0.99	8.20	8.32	68.22	1.29	1
R7x7.6	7.00 ± 0.15	—	7.60 ± 0.10	0.20	7.60	38.48	292.48	1.40	1
R8x22	8.00 ± 0.20	—	22.00 ± 0.60	0.44	22.00	50.26	1105.72	5.20	1
R8x25	8.00 ^{+0.00} / _{-0.30}	—	25.00 ± 0.80	0.50	25.00	50.24	1256.00	6.03	1
R9.4x8	9.40 ± 0.15	—	8.00 ± 0.20	0.46	8.00	17.34	138.72	2.63	1
R10x60	10.00 ± 0.20	—	60.00 ± 0.50	1.31	60.00	78.54	4712.39	22.38	1
R12x32	12.00 ± 0.30	11.00 ± 0.30	32.00 ± 1.00	0.28	32.00	113.09	3619.01	16.00	3
R14x0.8	14.00 ± 0.20	—	0.80 ± 0.10	0.01	0.80	153.93	123.14	0.59	1
R29x17.4	29.00 ± 0.40	—	17.40 ± 0.30	0.03	17.40	660.50	11492.71	54.30	4

Remark: Black epoxy coating, breakdown voltage : 500vdc min 3sec 0.5mA.

Type : ZT Cores

Ordering Code:

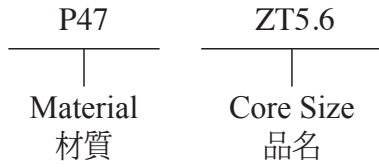

Shape:

Type:1

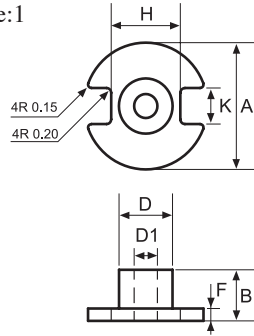

Type:2

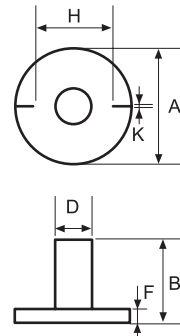

■ DIMENSIONS

CORES	DIMENSIONS (mm)							Wt(g/set)	Type
	A	C	D	D1	F	H	K		
ZT5.35H	5.50 ^{+0.00} / _{-0.30}	1.65 ^{+0.00} / _{-0.02}	2.40 ^{+0.00} / _{-0.15}	0.95 ^{+0.10} / _{-0.00}	1.10 ^{+0.15} / _{-0.00}	3.10 ^{+0.00} / _{-0.20}	1.40 ^{+0.20} / _{-0.00}	0.05	1
ZT5.6	5.60 ± 0.10	4.07ref	1.70 ± 0.10	—	3.90 ± 0.15	3.80ref	0.10ref	0.13	2

Type : I Cores

Ordering Code:

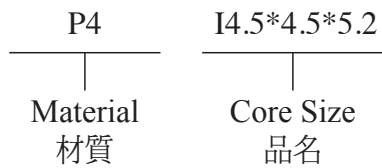

Shape:

Type:1

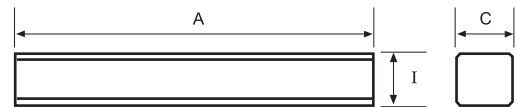

Type:2

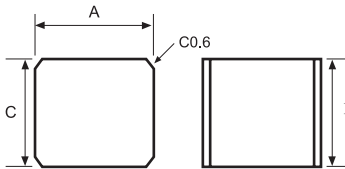

Type:3

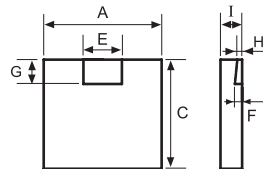

Type:4

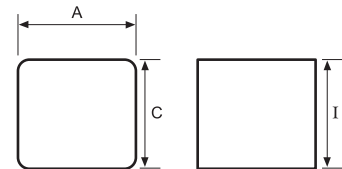

■ DIMENSIONS

CORES	DIMENSIONS (mm)							Wt(g/set)	Type
	A	C	E	F	H	I	G		
I3.95x3.95x5.55	3.95 ± 0.10	3.95 ± 0.10	—	—	—	5.55 ± 0.05	—	0.42	2
I4.5x4.5x5.2	4.50 ± 0.10	4.50 ± 0.10	—	—	—	5.20 ± 0.05	—	1.01	1
I4.6x3.2x3.43	4.60 ± 0.10	3.20 ± 0.10	—	—	—	3.43 ± 0.05	—	0.24	4
I4.8x4.85x5.85	4.80 ± 0.10	4.85 ± 0.10	—	—	—	5.75 ± 0.10	—	0.07	2
I5.7x3.45x6	5.70 ± 0.10	3.45 ± 0.10	—	—	—	6.00 ± 0.05	—	0.56	1
I6x3.45x5.7	6.00 ± 0.10	3.45 ± 0.10	—	—	—	5.70 ± 0.05	—	0.53	1
I6x4.2x7.28	6.00 ± 0.10	4.20 ± 0.10	—	—	—	7.28 ± 0.05	—	0.87	1
I6x6x7	6.00 ± 0.10	6.00 ± 0.10	—	—	—	7.00 ± 0.05	—	1.20	1
I6.1x4.9x7.5	6.10 ± 0.10	4.90 ± 0.10	—	—	—	7.50 ± 0.05	—	1.05	1
I6.5x4.85x7.5	6.50 ± 0.10	4.85 ± 0.10	—	—	—	7.50 ± 0.05	—	1.12	1
I7x5x6.3	7.00 ± 0.10	5.00 ± 0.10	—	—	—	6.30 ± 0.05	—	1.04	1
I8.6x7.7x2.85	8.60 ± 0.10	7.70 ± 0.10	—	—	—	2.85 ± 0.05	—	0.89	1
I24.52	24.52 ± 0.40	20.60 ± 0.30	8.00 ± 0.15	1.5ref	1.20 ± 0.10	4.50 ± 0.10	4.60 ± 0.15	10.75	3
I30x4x2	30.00 ± 0.50	4.00 ± 0.15	—	—	—	2.00 ± 0.15	—	1.12	1
I55x7x3	55.00 ± 1.00	7.00 ± 0.20	—	—	—	3.00 ± 0.10	—	5.54	1
I68x7x2.9	68.00 ± 1.00	7.00 ± 0.20	—	—	—	2.90 ± 0.10	—	6.63	1
I79.5x8x2.5	79.50 ± 1.00	8.00 ± 0.30	—	—	—	2.50 ± 0.15	—	7.63	1
I80x14.7x4	80.00 ± 1.20	14.70 ± 0.20	—	—	—	4.00 ± 0.10	—	22.65	1
I90x8x3.85	90.00 ± 1.50	8.00 ± 0.30	—	—	—	3.85 ± 0.15	—	13.31	1
I99.5x12x5	99.50 ± 2.00	12.00 ± 0.30	—	—	—	5.00 ± 0.15	—	28.66	1

Type : SC/UT Cores

Ordering Code:

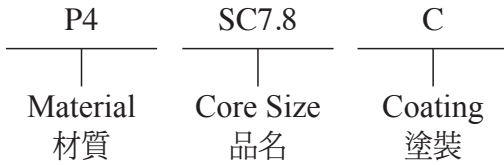

C : Epoxy Coating of Halogen-Free UC : Epoxy Coating of UL & Halogen
 HP : Parylene Coating of Halogen-Free P : Parylene Coating of Halogen

Shape:

Type:1

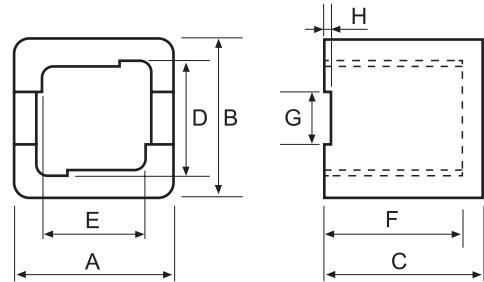

Type:2

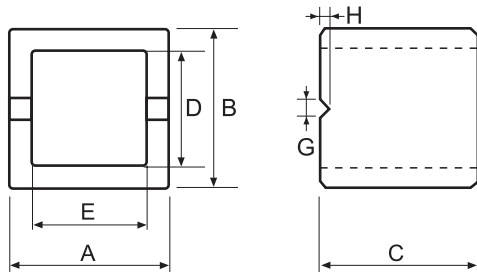

Type:3

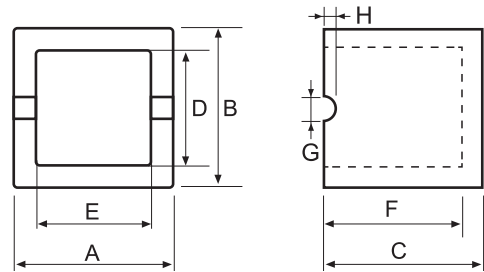

Type:4

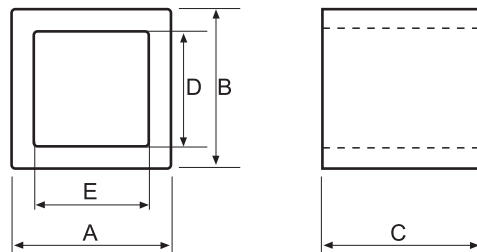

Type:5

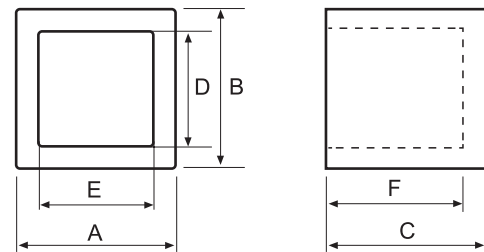

■ DIMENSIONS

CORES	DIMENSIONS (mm)								Wt(g/set)	Type
	COATING DIMENSIONS (mm)									
	A	B	C	D	E	F	G	H		
SC7.8	7.65 ± 0.15	7.65 ± 0.15	6.90 ± 0.20	5.75 ± 0.15	5.75 ± 0.15	5.70 ± 0.15	2.80 ± 0.10	0.20ref	0.97	1
	7.80 ± 0.20	7.10 ± 0.30	-	5.60 ^{+0.15} / _{-0.20}	5.60 ^{+0.15} / _{-0.20}	5.70 ± 0.25	2.50 ± 0.10	0.15ref		
SC10x9.6	10.00 ^{+0.20} / _{-0.10}	10.00 ^{+0.20} / _{-0.10}	9.50 ± 0.15	7.90 ± 0.15	6.15 ± 0.15	8.40 ± 0.15	-	0.70 ± 0.10	2.55	7
SC10A	10.00 ± 0.15	-	10.00 ± 0.30	6.01 ± 0.15	7.07 ± 0.15	8.85 ± 0.15	1.90ref	-	2.10	6
SC10B/9	10.00 ± 0.20	7.00 ± 0.20	9.50 ± 0.15	3.90 ± 0.20	7.90 ± 0.20	8.40 ± 0.20	-	1.00 ± 0.20	1.76	11
SC10.1Ax9.6	10.15 ± 0.20	10.15 ± 0.20	9.50 ± 0.20	8.00min	6.10 ± 0.10	7.00 ± 0.15	2.60ref	0.20ref	2.21	7
SC10.2x9.8	9.80 ± 0.15	10.20 ± 0.15	10.20 ± 0.15	8.10 ± 0.15	6.20 ± 0.15	8.70 ± 0.15	-	0.70 ± 0.10	3.10	7
SC10.3Ax9.2	10.30 ± 0.20	5.45 ± 0.15	9.20 ± 0.20	3.25 ± 0.15	8.10 ± 0.20	8.00 ± 0.20	-	-	1.40	10
SC11	11.00 ± 0.20	11.00 ± 0.20	9.50 ± 0.20	7.60 ± 0.15	7.60 ± 0.15	-	1.20ref	-	2.21	2
SC11x9.3	11.00 ± 0.15	9.00 ± 0.15	9.30 ± 0.20	6.35 ± 0.10	8.35 ± 0.10	8.30 ± 0.20	-	-	2.31	5
SC11x10	10.00 ± 0.30	11.00 ± 0.15	7.00 ± 0.15	6.00 ± 0.15	6.90 ± 0.20	-	-	-	2.21	8
SC11.3x10.75	11.30 ^{+0.25} / _{-0.10}	11.30 ^{+0.25} / _{-0.10}	10.75 ^{+0.15} / _{-0.10}	8.50 ± 0.15	7.80 ± 0.15	9.55 ± 0.15	-	-	3.50	7
SC11.3Ax10.75x8.5	11.30 ± 0.15	11.30 ± 0.15	10.75 ± 0.15	8.50 ± 0.15	7.80 ± 0.15	9.55 ± 0.15	-	-	3.55	3
SC11.4	11.20 ± 0.20	11.20 ± 0.20	9.30 ± 0.20	8.95 ± 0.15	8.55 ± 0.15	8.40 ± 0.20	3.85 ± 0.10	0.25ref	2.45	1
	11.40 ± 0.20	11.40 ± 0.20	9.50 ± 0.20	8.75 ± 0.20	8.35 ± 0.20	8.20 ± 0.20	3.75 ± 0.10	0.15ref		
SC12A	12.00 ± 0.15	-	10.00 ± 0.30	6.35 ± 0.15	8.50 ± 0.15	8.80 ± 0.15	-	-	3.14	9
SC12.3x10.75	12.30 ± 0.15	12.30 ± 0.15	10.75 ± 0.15	8.30 ± 0.15	8.60 ± 0.15	9.55 ± 0.15	-	-	4.46	3
SC12.75x9.8	12.75 ± 0.25	11.60 ± 0.25	9.80 ± 0.20	-	9.15 ± 0.20	8.00 ± 0.20	-	-	-	4

Type : SC/UT Cores

Ordering Code:

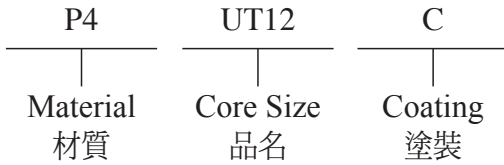

Shape:

Type:6

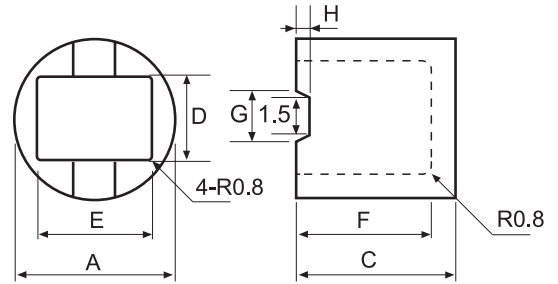

C : Epoxy Coating of Halogen-Free UC : Epoxy Coating of UL & Halogen
 HP : Parylene Coating of Halogen-Free P : Parylene Coating of Halogen

Type:7

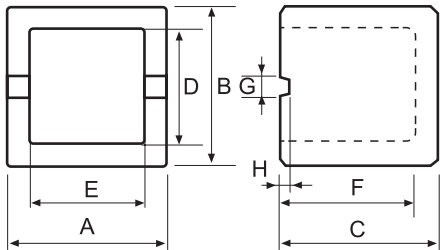

Type:8

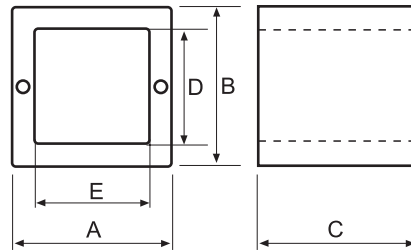

Type:9

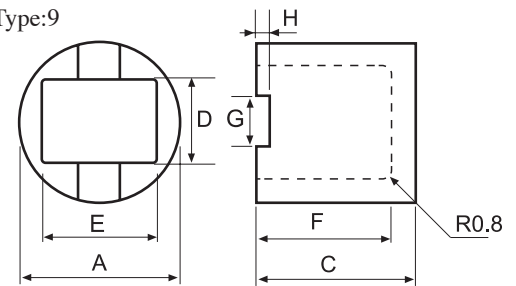

Type:10

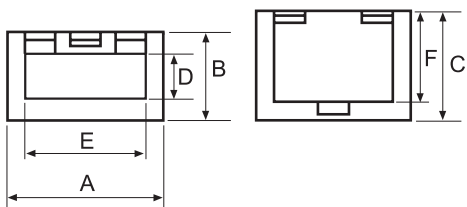

Type:11

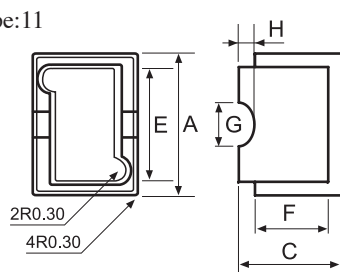

Type:12

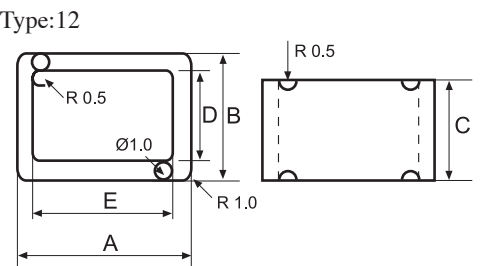

■ DIMENSIONS

CORES	DIMENSIONS (mm)								Wt(g/set)	Type
	COATING DIMENSIONS (mm)									
	A	B	C	D	E	F	G	H		
UT11.4	11.40 ± 0.20	8.20 ± 0.20	5.90 ^{+0.10} / _{-0.20}	-	8.70 ± 0.20	5.30 ± 0.20	-	-	1.31	12
UT11.4A	11.40 ± 0.20	8.00 ± 0.20	5.90 ^{+0.10} / _{-0.20}	-	8.60 ± 0.20	3.50 ± 0.20	-	-	1.68	12
UT11.5	10.80 ± 0.15	11.50 ± 0.15	10.00 ± 0.15	8.20 ± 0.15	6.80 ± 0.15	-	-	-	3.34	8
UT11.5/7.8	10.80 ± 0.15	11.50 ± 0.15	7.80 ± 0.15	8.20 ± 0.15	6.80 ± 0.15	-	-	-	2.50	8
UT11.5A	10.80 ± 0.15	11.55 ± 0.15	8.85 ± 0.15	8.70 ± 0.15	6.80 ± 0.15	-	-	-	2.71	8
UT11.5B	11.50 ± 0.20	9.20 ± 0.20	7.80 ± 0.20	-	8.25 ± 0.15	6.05 ± 0.15	-	-	2.04	3
UT11.5D	11.50 ± 0.20	8.20 ± 0.20	7.80 ^{+0.30} / _{-0.00}	-	9.20 ^{+0.30} / _{-0.00}	5.50 ^{+0.30} / _{-0.00}	-	-	1.82	2
UT12	12.75 ± 0.20	11.60 ± 0.20	9.80 ± 0.20	8.00 ± 0.20	9.15 ± 0.20	-	-	-	3.44	4
	13.55max	12.40max	10.60max	7.20min	8.35min	-	-	-		
UT12/10	12.75 ± 0.20	11.60 ± 0.20	10.00 ± 0.20	8.00 ± 0.20	9.15 ± 0.20	-	-	-	3.51	4
UT12A	12.75 ± 0.20	9.75 ± 0.20	9.80 ± 0.20	6.15 ± 0.20	9.15 ± 0.20	-	-	-	3.14	4

Type : ER Cores (1)

Ordering Code:

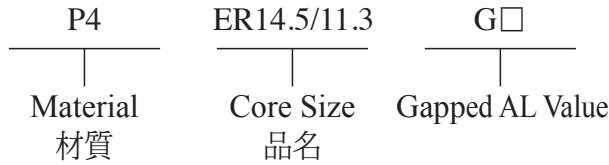

Shape:

Type:1

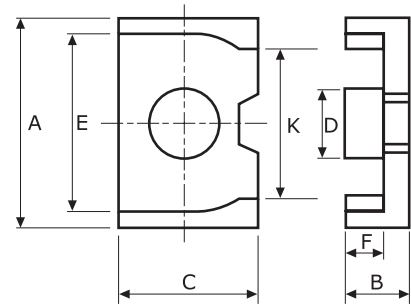

Type:2

Type:3

Type:4

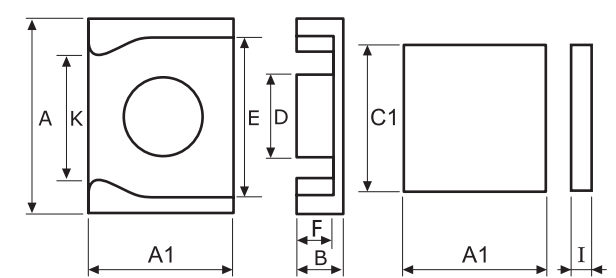
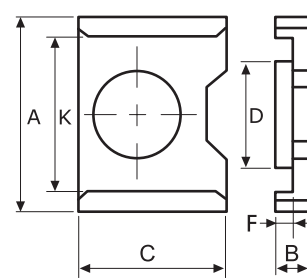
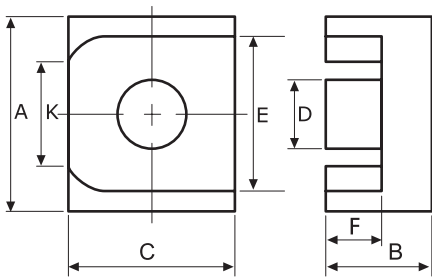

■ DIMENSIONS

CORES	DIMENSIONS (mm)										Type
	A	B	C	D	E	F	K	AI	CI	I	
ER10/4.3	9.90 ± 0.15	2.15 ± 0.10	7.80 ^{+0.10} / _{-0.13}	3.70 ± 0.10	8.10 ^{+0.15} / _{-0.10}	1.10 ^{+0.08} / _{-0.07}	6.50 ± 0.15	-	-	-	1
ER10/4.46	9.90 ± 0.20	2.23 ± 0.10	7.80 ± 0.15	3.70 ± 0.10	8.10 ± 0.20	1.13 ± 0.10	6.50 ± 0.15	-	-	-	1
ER12/9/5	12.20 ± 0.15	2.50 ± 0.08	9.00 ^{+0.13} / _{-0.12}	5.55 ± 0.10	10.00 ± 0.15	1.00 ± 0.08	8.60 ± 0.15	-	-	-	1
ER12/9/5.2	12.20 ± 0.20	2.60 ± 0.08	9.00 ± 0.15	5.55 ± 0.10	10.00 ± 0.20	1.10 ± 0.08	8.60 ± 0.15	-	-	-	1
ER12/9/5.7	12.20 ± 0.20	2.87 ± 0.06	9.00 ± 0.15	5.55 ± 0.10	10.00 ± 0.20	1.37 ± 0.06	8.60 ± 0.15	-	-	-	1
ER12/9/7	12.20 ± 0.20	3.50 ± 0.08	9.00 ± 0.15	5.55 ± 0.10	10.00 ± 0.15	2.00 ± 0.08	8.60 ± 0.15	-	-	-	1
ER12/9/8	12.20 ± 0.20	4.00 ± 0.06	9.00 ± 0.15	5.55 ± 0.10	10.00 ± 0.15	2.50 ± 0.06	8.60 ± 0.15	-	-	-	1
ER12.45/9/5.1	12.45 ± 0.15	2.55 ± 0.08	9.00 ± 0.15	5.60 ± 0.10	10.25 ± 0.15	1.15 ^{+0.10} / _{-0.08}	8.60 ± 0.15	-	-	-	1
ER13.6/9.35/4.5	13.60 ± 0.15	2.25 ± 0.10	9.35 ± 0.10	5.60 ^{+0.08} / _{-0.15}	11.05min	1.20 ± 0.10	-	-	-	-	3
ER14.5/11.3	14.50 ± 0.20	4.10 ± 0.10	11.30 ± 0.20	6.00 ± 0.12	12.20 ± 0.15	2.90 ± 0.10	8.30 ± 0.15	-	-	-	2
ERI14.5B/11.3	14.5 ± 0.30	5.60 ± 0.10	11.30 ± 0.25	6.00 ± 0.10	12.20 ± 0.30	4.40 ± 0.10	9.27 ± 0.30	14.50 ± 0.30	11.30 ± 0.25	1.20 ± 0.10	4

■ EFFECTIVE PARAMETERS

CORES	EFFECTIVE PARAMETERS				
	$C_t(\text{mm}^{-1})$	Le(mm)	Ae(mm ²)	Ve(mm ³)	Wt(g/set)
ER10/4.3	0.75	11.51	15.20	174.95	1.16
ER10/4.46	0.78	11.80	15.12	178.42	1.20
ER12/9/5	0.50	13.39	26.72	357.78	2.34
ER12/9/5.2	0.48	14.66	30.70	450.06	2.64
ER12/9/5.7	0.56	14.87	26.46	393.46	2.52
ER12/9/7	0.54	13.89	25.62	355.86	2.52
ER12/9/8	0.74	19.36	25.95	502.39	2.64
ER12.45/9/5.1	0.59	14.01	23.94	335.40	1.92
ER13.6/9.35/4.5	0.69	14.66	21.27	311.68	2.02
ER14.5/11.3	0.70	20.12	28.53	574.02	3.46
ERI14.5B/11.3	0.76	21.71	28.48	618.30	3.12

■ ELECTRICAL CHARACTERISTICS

CORES	AL ± 25% (nH/N ²)							
	P4	P41	P46	P47	P5	P51	P52	N42
ER10/4.3	1750	1700			1560	1280	1560	
ER10/4.46	1850							
ER12/9/5	3330	2600	3700		2550	2170		3350
ER12/9/5.2	3200							
ER12/9/5.7	3100		3150	2850	2400			3170
ER12/9/7	2530							
ER12/9/8	2350		2700		1880	1550		
ER12.45/9/5.1	3300							
ER13.6/9.35/4.5	1950	1850						
ER14.5/11.3	2500	2400	3000					
ERI14.5B/11.3		2300						

Remark:

1. AL Value Testing Condition : 10kHz, 50mV, 100Ts. If testing condition is different from ACME's, please specify upon request & ordering.
2. Gapped core is available, please specify upon request & ordering. ACME's standard gapped core set is a combination of one gapped core and one ungapped core. If gapping on both pcs to make a set is needed, please specify upon request & ordering.



■ EFFECTIVE PARAMETERS

CORES	EFFECTIVE PARAMETERS				
	C _i (mm ⁻¹)	Le(mm)	Ae(mm ²)	Ve(mm ³)	Wt(g/set)
ER7.5/5	2.26	13.06	5.78	75.51	0.35
ER17.5/5	1.53	8.94	5.84	52.17	0.31
ER9.5/3.6	1.22	11.14	9.16	102.04	0.48
ER9.5/5	1.56	13.63	8.73	118.99	0.62
ER11/3.9	1.01	12.14	11.92	144.70	0.80
ER11/5	1.17	14.18	12.13	172.00	0.90
ER11.63/5.15	1.29	15.29	11.87	181.49	1.00
ER13/5.4	0.82	16.24	19.82	321.88	1.84
ER14.5/6	1.07	18.38	17.13	314.85	1.69
ER14.5/6.8	1.17	20.18	17.18	346.69	1.90
ER14.5/9.4	1.49	25.46	17.13	436.13	2.38
ER19	1.34	33.89	25.34	858.77	4.80
ER20/9.5/6.25	0.96	34.07	35.42	1206.76	7.00
ER21.2	1.36	43.65	32.06	1399.42	8.64
ER25.5	0.70	28.80	41.21	1186.73	6.18
ER25.5A	0.67	31.83	47.24	1503.59	8.92
ER26.6	0.93	30.70	33.00	1013.10	8.70
ER29.8	0.50	24.19	48.39	1170.35	10.32
ER33	0.62	28.70	46.33	1329.40	10.26
ER63	0.27	104.58	389.13	40696.00	222.60

■ ELECTRICAL CHARACTERISTICS

CORES	AL ± 25% (nH/N ²)										AL ± 30% (nH/N ²)		
	P4	P41	P42	P46	P47	P5	P51	N42	A05	A07	A10(L)	A121(L)	A151(L)
ER7.5/5	710			730		630	450	775	950				
ER17.5/5		800											
ER9.5/3.6	1090												
ER9.5/5	950	930	740	1080	1040	880	660	1090	1250	1580	3600	3200min	3700min
ER11/3.9	1040min	1340								2224	6600		
ER11/5	1400	1370	1180	1640	1560	1120	950	1490	2100	2380	6400	6980	
ER11.63/5.15	1150												
ER13/5.4			1640		2110								
ER14.5/6	1700	1600	1275	1830	1800	1360	1210	1970	2200	2600	6600	8000	6000min
ER14.5/6.8	1300						1000						
ER14.5/9.4	1450												
ER19	1400												
ER20.5/9.5/6.25	2100												
ER21.2	1400												
ER25.5	3000												
ER25.5A		2500											
ER26.6					3000								
ER29.8		3700											
ER33	4100												
ER63	8355												

Remark:

1. AL Value Testing Condition : 10kHz, 50mV, 100Ts. If testing condition is different from ACME's, please specify upon request & ordering.
2. Gapped core is available, please specify upon request & ordering. ACME's standard gapped core set is a combination of one gapped core and one ungapped core. If gapping on both pcs to make a set is needed, please specify upon request & ordering.
3. L : Mirror Finished Lapping. Please specify upon request & ordering by adding "L" at the end of Core Size if you need.

Type : ER Cores (3)

Shape:

Type:1

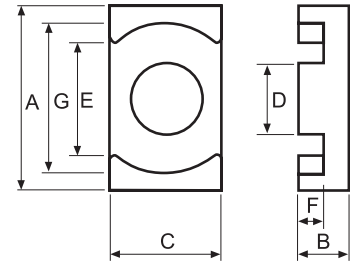

Ordering Code:
 P4 ERI20 G□
 Material Core Size Gapped AL Value
 材質 品名

Type:2

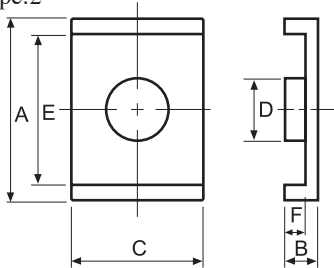

Type:3

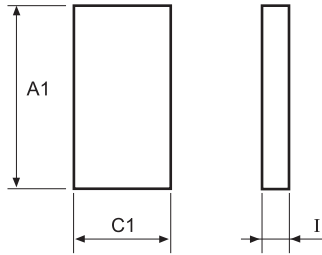

Type:4

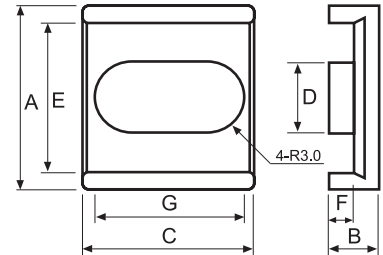

Type:5

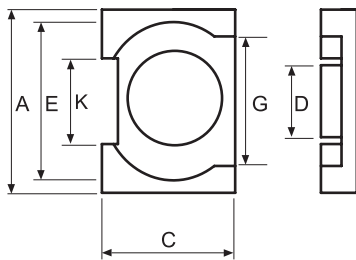

Type:6

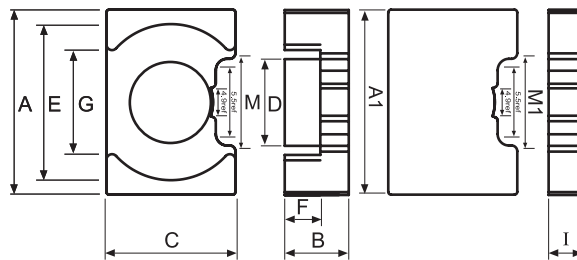

Type:7

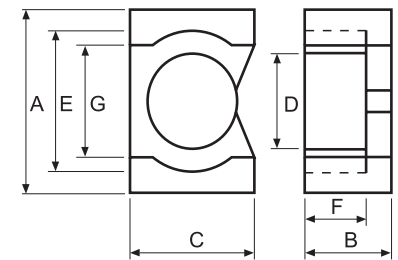

■ DIMENSIONS

CORES	DIMENSIONS (mm)											Type
	A	B	C	D	E	F	G	K	A1	C1	I	
ER13	12.80 ± 0.20	2.85 ± 0.06	8.70 ± 0.20	5.00 ± 0.10	9.05 ± 0.15	1.75 ± 0.06	11.20 ± 0.20	-	-	-	-	1
ER13/5.6	12.80 ± 0.20	2.80 ± 0.06	8.70 ± 0.20	5.00 ± 0.10	9.05 ± 0.15	1.70 ± 0.06	11.20 ± 0.20	-	-	-	-	1
ERI13	12.80 ± 0.20	2.85 ± 0.06	8.70 ± 0.20	5.00 ± 0.10	9.05 ± 0.15	1.75 ± 0.06	11.20 ± 0.20	-	12.80 ± 0.20	8.70 ± 0.20	1.10 ± 0.05	1 + 3
ER18	18.00 ± 0.35	3.15 ± 0.10	9.70 ± 0.20	6.20 ± 0.15	13.50min	1.60 ± 0.10	15.60 ± 0.30	-	-	-	-	1
ER18/7	18.00 ± 0.35	3.50 ± 0.10	9.70 ± 0.20	6.20 ± 0.15	13.50min	1.95 ± 0.10	15.60 ± 0.30	-	-	-	-	1
ER18A	18.00 ± 0.35	4.00 ± 0.15	10.00 ± 0.20	7.20 ± 0.20	14.00 ± 0.20	2.00 ± 0.15	-	-	-	-	-	2
ER18.8/14.5	19.05 ± 0.25	3.45 ± 0.10	14.75 ± 0.25	6.80 ± 0.10	16.30 ± 0.15	2.20 ± 0.10	-	-	-	-	-	2
ER20/8.2	20.00 ± 0.30	8.20 ± 0.10	14.00 ± 0.30	8.80 ± 0.15	13.10 ± 0.25	6.00 ± 0.15	18.00 ± 0.30	-	-	-	-	1
ERI20	20.00 ± 0.30	5.70 ± 0.10	14.00 ± 0.30	8.80 ± 0.15	13.10 ± 0.25	3.50 ± 0.15	18.00 ± 0.30	-	20.00 ± 0.30	14.00 ± 0.30	2.20 ± 0.05	1 + 3
ERI20/8.2	20.00 ± 0.30	8.20 ± 0.10	14.00 ± 0.30	8.80 ± 0.15	13.10 ± 0.25	6.00 ± 0.15	18.00 ± 0.30	-	20.00 ± 0.30	14.00 ± 0.30	2.20 ± 0.05	1 + 3
ERI22.2/15.8/6.7/2.5	22.20 ± 0.30	6.70 ± 0.10	15.80 ± 0.30	10.00 ± 0.20	18.20 ± 0.30	4.20 ± 0.15	-	-	22.20 ± 0.30	15.80 ± 0.30	2.50 ± 0.05	2 + 3
ER22.7/14/7.1/2.2	22.75 ± 0.25	7.10 ± 0.10	14.00 ± 0.30	8.80 ± 0.15	15.40min	4.90 ± 0.15	20.25 ± 0.25	-	22.75 ± 0.25	14.00 ± 0.30	2.20 ± 0.10	1 + 3
ER23	23.20 ± 0.45	3.60 ± 0.10	12.50 ± 0.25	8.00 ± 0.20	17.50min	1.60 ± 0.15	20.20 ± 0.40	-	-	-	-	1
ER25	25.00 ± 0.40	6.05 ± 0.10	18.00 ± 0.30	11.00 ± 0.20	14.50min	3.55 ± 0.15	22.00 ± 0.40	-	-	-	-	1
ER25/8.2	25.00 ± 0.40	4.10 ± 0.10	18.00 ± 0.30	11.00 ± 0.20	14.50min	1.70 ± 0.15	22.00 ± 0.40	-	-	-	-	1
ERI25	25.00 ± 0.40	6.05 ± 0.05	18.00 ± 0.30	11.00 ± 0.20	14.50min	3.55 ± 0.15	22.00 ± 0.40	-	25.00 ± 0.40	18.00 ± 0.30	2.30 ± 0.05	1 + 3
ER25.7	25.70 ± 0.40	5.25 ± 0.15	25.35 ± 0.40	6.50 ± 0.20	19.50 ± 0.40	3.00 ± 0.15	24.35 ± 0.35	-	-	-	-	4
ER28A	28.00 ± 0.50	5.60 ± 0.20	22.65 ± 0.50	11.00 ± 0.20	24.20 ± 0.50	3.00 ± 0.20	19.80 ± 0.40	13.10 ± 0.40	-	-	-	5
ER30/8	30.00 ± 0.40	8.00 ± 0.15	20.00 ± 0.30	11.00 ± 0.20	19.45 ± 0.30	5.30 ± 0.20	26.00 ± 0.30	-	-	-	-	1
ERI32	32.00 ± 0.50	13.50 ± 0.25	23.00 ± 0.40	15.00 ± 0.20	27.00 ± 0.30	7.65 ± 0.35	18.00 ± 0.30	-	32.00 ± 0.50	23.00 ± 0.40	6.00 ± 0.25	6
ER33/60	33.00 ± 0.50	30.00 ± 0.20	24.00 ± 0.40	17.20 ± 0.35	25.50 ± 0.50	25.00 ± 0.20	21.00max	-	-	-	-	7



■ EFFECTIVE PARAMETERS

CORES	EFFECTIVE PARAMETERS				
	C _t (mm ⁻¹)	Le(mm)	Ae(mm ²)	Ve(mm ³)	Wt(g/set)
ER13	0.91	18.10	19.90	360.00	1.86
ER13/5.6	0.91	16.60	18.30	303.78	1.46
ERI13	0.64	13.23	20.76	274.69	1.13
ER18	0.67	20.85	31.31	652.81	3.36
ER18/7	0.74	22.37	30.26	676.92	3.78
ER18A	0.46	20.24	44.43	899.26	5.00
ER18.8/14.5	0.64	23.98	37.45	897.86	4.99
ER20/8.2	0.60	29.00	48.35	1402.15	15.08
ERI20	0.40	23.80	59.80	1425.00	7.99
ERI20/8.2	0.48	27.10	56.24	1524.10	18.08
ERI22.2/15.8/6.7/2.5	0.35	32.69	75.07	2454.04	11.17
ER22.7/14/7.1/2.2	0.50	30.21	60.80	1836.77	9.44
ER23	0.48	25.08	51.79	1298.89	6.94
ER25	0.31	31.84	103.60	3298.60	17.56
ER25/8.2	0.28	24.89	88.99	2214.96	13.30
ERI25	0.29	26.40	89.70	2370.00	13.57
ER25.7	0.25	33.00	131.74	4347.60	22.50
ER28A	0.36	36.48	106.49	3884.76	22.10
ER30/8	0.38	43.22	113.39	4900.00	28.00
ERI32	0.23	43.90	195.00	8561.00	51.80
ER33/60	0.54	130.08	239.55	31160.66	149.10

■ ELECTRICAL CHARACTERISTICS

CORES	AL ± 25% (nH/N ²)									
	P4	P41	P42	P46	P47	P48	P5	P51	P52	N42
ER13	2000	1930	1600	2150	2040		1700	1250		
ER13/5.6			1610							
ERI13	2100	2035	1800	2600			1910	1600	1910	
ER18	2650	2400	2000	3130			2300	1770		3380
ER18/7			1950	2900						
ER18A	3500									
ER18.8/14.5	2900	2800						1790		
ER20/8.2	3370									
ERI20	5000	4860	3500	5540			3900	3060		
ERI20/8.2	3900									
ERI22.2/15.8/6.7/2.5		5000								
ER22.7/14/7.1/2.2				5000						
ER23	3465	3400		3950				2550		
ER25	5800	5700	4880	8000	7200		5310	4220	5310	
ER25/8.2		7000								
ERI25	7000	6810	4870	7800	7500		5600	4240		
ER25.7	8500									
ER28A		6000								
ER30/8	4300	4100					3600			
ERI32					11000					
ER33/60					6500					

Remark:

1. AL Value Testing Condition : 10kHz, 50mV, 100Ts. If testing condition is different from ACME's, please specify upon request & ordering.
2. Gapped core is available, please specify upon request & ordering. ACME's standard gapped core set is a combination of one gapped core and one ungapped core. If gapping on both pcs to make a set is needed, please specify upon request & ordering.

Type : EPO Cores

Ordering Code:

P4

EPO13

G□

 Material
材質

 Core Size
品名

Gapped AL Value

Shape:

Type:1

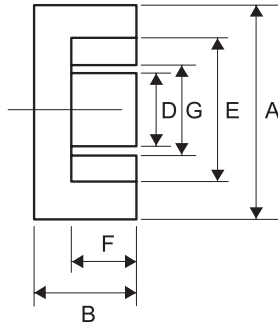
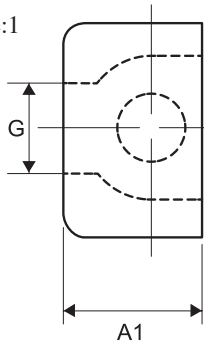

Type:2

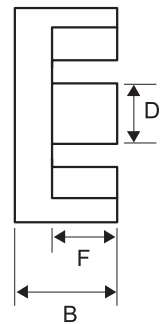
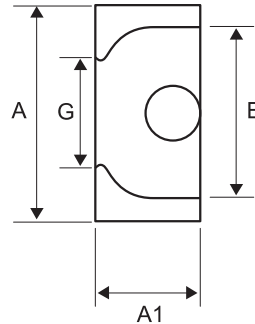

■ DIMENSIONS

CORES	DIMENSIONS (mm)							Type
	A	B	A1	D	E	F	G	
EPO11.5	11.50 ± 0.30	5.20 ± 0.10	6.10 ± 0.20	3.30 ± 0.15	9.40 ± 0.20	3.70 ± 0.10	5.85ref	2
EPO13	12.50 ± 0.30	6.43 ± 0.10	7.20 ± 0.20	4.35 ± 0.15	10.00 ± 0.30	4.60 ± 0.10	5.90 ± 0.15	1

■ EFFECTIVE PARAMETERS

CORES	EFFECTIVE PARAMETERS				
	C _i (mm ⁻¹)	Le(mm)	Ae(mm ²)	Ve(mm ³)	Wt(g/set)
EPO11.5	2.26	21.42	9.46	202.63	2.00
EPO13	1.34	25.80	19.30	497.94	3.08

■ ELECTRICAL CHARACTERISTICS

CORES	AL ± 25% (nH/N ²)					AL ± 30% (nH/N ²)			
	P4	P5	N42	A05	A05(L)	A10(L)	A101(L)	A12	A12(L)
EPO11.5			1000						
EPO13	1550					6700	6700	7700	

Remark:

1. AL Value Testing Condition : 10kHz, 50mV, 100Ts. If testing condition is different from ACME's, please specify upon request & ordering.
2. Gapped core is available, please specify upon request & ordering. ACME's standard gapped core set is a combination of one gapped core and one ungapped core. If gapping on both pcs to make a set is needed, please specify upon request & ordering.

Type : EP Cores

Ordering Code:

P4

EP7

G□

 Material
材質

 Core Size
品名

Gapped AL Value

Shape:

Type:1

Type:2

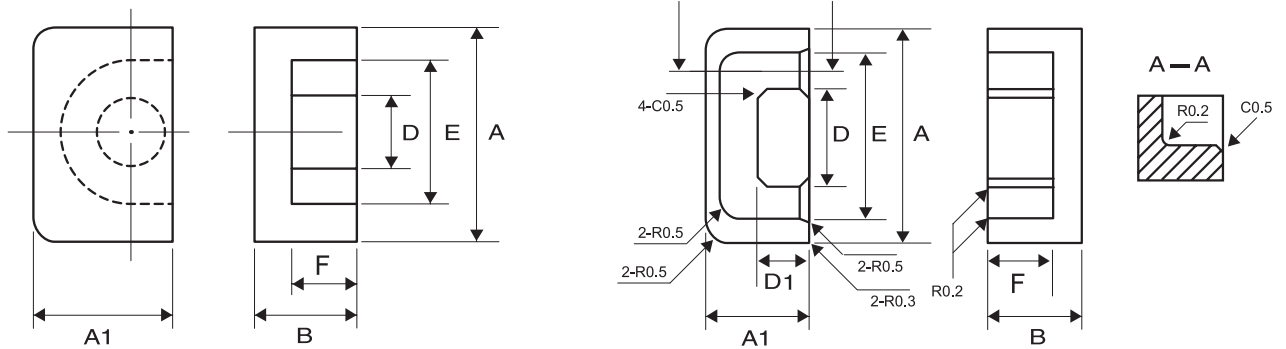

■ DIMENSIONS

CORES	DIMENSIONS (mm)						
	A	A1	B	D	E	F	Type
EP5	6.00 ± 0.15	3.80 ± 0.10	2.80 ± 0.05	1.70 ± 0.10	4.40 ± 0.15	2.00 ± 0.10	1
EP5-1	6.00 ± 0.15	3.80 ± 0.10	3.40 ± 0.05	1.70 ± 0.10	4.40 ± 0.15	2.60 ± 0.10	1
EP7	9.20 ± 0.20	6.35 ± 0.15	3.75 $\begin{smallmatrix} +0.00 \\ -0.10 \end{smallmatrix}$	3.30 ± 0.10	7.40 ± 0.20	2.60 ± 0.10	1
EP7-1	9.20 ± 0.20	6.35 ± 0.15	4.75 ± 0.05	3.30 ± 0.10	7.40 ± 0.20	3.60 ± 0.10	1
EP7C	9.40 ± 0.20	6.50 ± 0.15	3.70 ± 0.10	3.30 ± 0.10	7.40min	2.60 ± 0.10	1
EP10	11.50 ± 0.30	7.65 ± 0.20	5.20 $\begin{smallmatrix} +0.00 \\ -0.10 \end{smallmatrix}$	3.30 ± 0.15	9.40 ± 0.20	3.70 ± 0.10	1
EP10B	11.50 ± 0.30	7.65 ± 0.20	5.20 ± 0.10	3.30 ± 0.15	9.40 ± 0.20	3.70 ± 0.10	1
EP13	12.50 ± 0.30	8.80 ± 0.20	6.50 $\begin{smallmatrix} +0.00 \\ -0.15 \end{smallmatrix}$	4.35 ± 0.15	10.10 ± 0.20	4.60 ± 0.10	1
EP13.3	13.30 ± 0.20	5.50 ± 0.15	6.50 ± 0.10	5.60 ± 0.10	10.80 ± 0.20	4.55 ± 0.10	2
EP15.2	15.20 ± 0.30	11.00 ± 0.20	7.10 ± 0.15	5.40 ± 0.20	11.00min	4.60 ± 0.15	1
EP17	18.00 ± 0.40	11.00 ± 0.20	8.40 ± 0.20	5.68 ± 0.18	12.00 ± 0.40	5.65 ± 0.15	1

■ EFFECTIVE PARAMETERS

CORES	EFFECTIVE PARAMETERS				
	C _t (mm ⁻¹)	Le(mm)	Ae(mm ²)	Ve(mm ³)	Wt(g/set)
EP5	3.20	9.70	3.00	28.70	0.46
EP5-1	3.60	10.80	3.00	32.40	0.46
EP7	1.52	15.70	10.30	162.00	1.42
EP7-1	1.68	17.96	10.66	191.45	1.42
EP7C	1.44	15.37	10.67	164.00	1.44
EP10	1.70	19.20	11.30	217.00	2.92
EP10B	1.70	19.20	11.30	216.96	2.76
EP13	1.24	24.20	19.50	472.00	4.86
EP13.3	1.40	24.42	17.35	423.68	3.14
EP15.2	0.81	24.82	30.76	763.41	4.50
EP17	0.84	28.70	34.00	970.00	11.60

■ ELECTRICAL CHARACTERISTICS

CORES	AL + 30% - 20% (nH/N ²)					AL + 40% - 30% (nH/N ²)				
	P4	P5	N42	A05	A05(L)	A101	A101(L)	A121	A121(L)	A151(L)
EP5	400 ± 25%	380 ± 25%	500 ± 25%			600	1900	650	2050	1852min
EP5-1	380 ± 25%		450 ± 25%				1850			
EP7	1100	1000	1350 ± 25%	2000	3500	2050	5200	2100	3900min	4800min
EP7-1						1980				
EP7C	1100									
EP10	1000	950	1270 ± 25%	2000	3400	2050 ± 30%	4800	2150	3950min	4800min
EP10B	1000									
EP13	1600	1430		2800	4400	3300	7000	3500	5800min	7000min
EP13.3										6446min
EP15.2						5160 (ref)				
EP17	2500		3060 ± 25%	3970 ± 25%			11000		12600	

Remark:

1. AL Value Testing Condition : 10kHz, 50mV, 100Ts. If testing condition is different from ACME's, please specify upon request & ordering.
2. Gapped core is available, please specify upon request & ordering. ACME's standard gapped core set is a combination of one gapped core and one ungapped core. If gapping on both pcs to make a set is needed, please specify upon request & ordering.
3. L : Mirror Finished Lapping. Please specify upon request & ordering by adding "L" at the end of Core Size if you need.

Type : CUT Cores

Ordering Code:

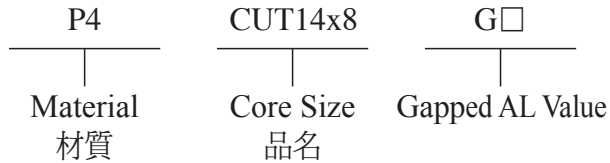

Shape:

Type:1

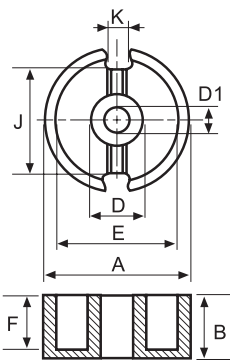

Type:2

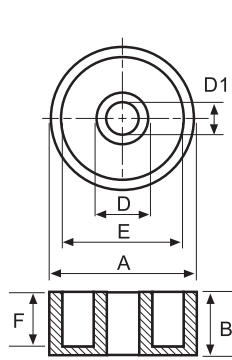

Type:3

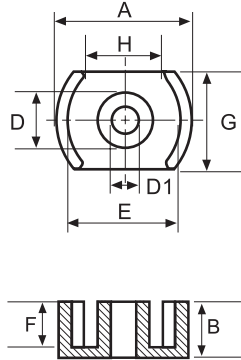

Type:4

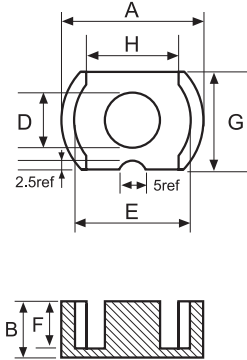

Type:5

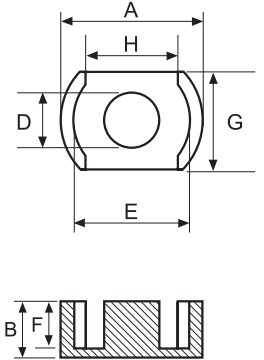

■ DIMENSIONS

CORES	DIMENSIONS (mm)										Type
	A	B	D	E	F	J	K	D1	G	H	
CUT14x8	14.00 ± 0.25	4.18 ± 0.06	6.09max	11.60min	2.79min	9.50 ± 0.60	3.30 ± 0.60	—	9.55 ± 0.15	7.60min	1 + 3
CUT14x8CH	14.00 ± 0.25	4.18 ± 0.08	6.09max	11.60min	2.79min	9.50 ± 0.60	3.30 ± 0.60	3.10 ± 0.07	9.55 ± 0.15	7.60min	1 + 3
CUT18x11CH	17.90 ± 0.30	5.30 ± 0.07	7.40 ± 0.15	15.25 ± 0.25	3.80 ± 0.10	11.55 ± 0.30	3.20 ± 0.30	3.02 ± 0.07	11.90 ± 0.20	10.50min	1 + 3
CUT23x11CH	22.86 ± 0.45	5.53 ± 0.25	9.90max	17.93min	3.63min	—	—	5.08 ± 0.10	15.24 ± 0.25	13.21min	2 + 3
DCUT14x8	14.00 ± 0.25	4.18 ± 0.06	6.09max	11.60min	2.79min	—	—	—	9.55 ± 0.15	7.60min	5
DCUT14x8CH	14.00 ± 0.25	4.18 ± 0.08	6.09max	11.60min	2.79min	—	—	3.10 ± 0.07	9.55 ± 0.15	7.60min	3
DCUT18x11CH	17.90 ± 0.30	5.30 ± 0.07	7.40 ± 0.15	15.25 ± 0.25	3.80 ± 0.10	—	—	3.02 ± 0.07	11.90 ± 0.20	10.50min	3
DCUT21.6	21.60 ± 0.40	4.10 ± 0.25	9.40 ± 0.20	17.50 ± 0.30	2.35 ± 0.15	—	—	—	15.20 ± 0.25	10.95ref	5
DCUT22.9x15.2	22.90 ± 0.45	5.55 ± 0.15	9.75 ± 0.15	18.25 ± 0.30	3.75 ± 0.15	—	—	—	15.20 ± 0.25	10.95ref	5
DCUT30	30.20 ± 0.50	9.50 ± 0.10	12.50 ± 0.20	24.70 ± 0.40	6.60 ± 0.10	—	—	—	20.50 ± 0.25	16.80 ± 0.25	5
DCUT33.2x11	33.20 ± 0.40	5.56 ± 0.15	13.50 ± 0.25	26.60 ± 0.40	3.25 ± 0.15	—	—	—	23.70 ± 0.30	18.00min	4
DCUT33.2x12	33.20 ± 0.50	6.10 ± 0.15	13.50 ± 0.20	26.60 ± 0.40	3.20 ± 0.15	—	—	—	23.70 ± 0.30	18.20min	5
DCUT33.2A/18.9	33.20 ± 0.50	9.45 ± 0.15	13.40 ± 0.20	26.80 ± 0.40	6.65 ± 0.15	—	—	—	23.70 ± 0.30	18.20min	5
DCUT40x13.5	39.80 ± 0.50	6.75 ± 0.15	16.00 ± 0.25	33.30 ± 0.50	4.35 ± 0.15	—	—	—	28.30 ± 0.35	21.00min	5

* CUT Core = 1 PC POT Core + 1 PC CUT Core.

* DCUT Core = 2 PCS CUT Cores.

■ EFFECTIVE PARAMETERS

CORES	EFFECTIVE PARAMETERS				
	C _i (mm ⁻¹)	Le(mm)	Ae(mm ²)	Ve(mm ³)	Wt(g/set)
CUT14x8	0.71	20.90	29.20	610.00	2.91
CUT14x8CH	0.91	21.10	23.30	492.00	2.66
CUT18x11CH	0.67	27.20	40.60	1110.00	5.40
CUT23x11CH	0.47	28.60	61.00	1744.60	11.94
DCUT14x8	0.70	21.00	29.90	627.90	2.91
DCUT14x8CH	1.02	22.50	22.00	495.00	2.66
DCUT18x11CH	0.78	27.20	35.00	952.00	6.00
DCUT21.6	0.42	25.82	61.11	1577.86	8.50
DCUT22.9x15.2	0.54	35.10	64.90	2278.08	12.14
DCUT30	0.45	50.20	111.00	5572.20	30.96
DCUT33.2x11	0.28	36.70	131.90	4836.40	25.10
DCUT33.2x12	0.24	33.84	143.88	4869.14	37.12
DCUT33.2A/18.9	0.36	52.62	144.58	7607.80	39.20
DCUT40x13.5	0.27	44.00	161.00	7084.00	40.60

■ ELECTRICAL CHARACTERISTICS

CORES	AL ± 25% (nH/N ²)						AL + 40% - 30% (nH/N ²)		
	P4	P47	P5	N4	N42	N43	A05	A10(L)	A121(L)
CUT14x8	2180		1880	2180				5490 ± 30%	6220 ± 30%
CUT14x8CH	1650			1650			2500+30%-25%	8000	
CUT18x11CH	2500			2500			4800+30%-25%	10000	
CUT23x11CH	4600		3500						
DCUT14x8	2000		1500						
DCUT14x8CH			1440						
DCUT18x11CH	2500								
DCUT21.6	3300								
DCUT22.9x15.2	3600								
DCUT30	5500		4500	5500					
DCUT33.2x11		7000							
DCUT33.2x12		6800							
DCUT33.2A/18.9		6500							
DCUT40x13.5	8500								

Remark:

1. AL Value Testing Condition : 10kHz, 50mV, 100Ts. If testing condition is different from ACME's, please specify upon request & ordering.
2. Gapped core is available, please specify upon request & ordering. ACME's standard gapped core set is a combination of one gapped core and one ungapped core. If gapping on both pcs to make a set is needed, please specify upon request & ordering.
3. L : Mirror Finished Lapping. Please specify upon request & ordering by adding "L" at the end of Core Size if you need.

Type : POT Cores

Ordering Code:

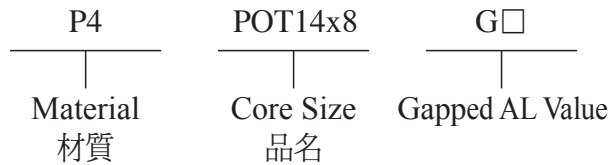

Shape:

Type:1

Type:2

Type:3

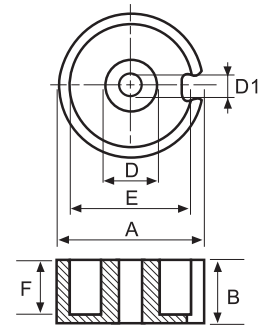
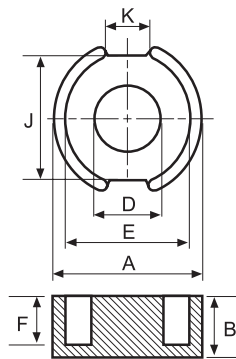
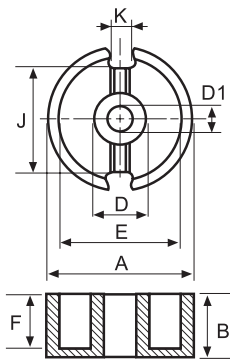

■ DIMENSIONS

CORES	DIMENSIONS (mm)								Type
	A	B	D	E	F	J	K	D1	
POT3.35x2.6	3.30 ^{+0.15} _{-0.05}	1.30 ± 0.10	1.10 ^{+0.12} _{-0.08}	2.60 ^{+0.15} _{-0.05}	0.85 ^{+0.20} _{-0.00}	—	—	—	2
POT5.5x8	5.50 ^{+0.00} _{-0.30}	4.00 ^{+0.00} _{-0.15}	2.35 ± 0.10	4.50 ^{+0.00} _{-0.30}	3.28 ± 0.10	4.29 ± 0.15	1.50 ± 0.10	—	2
POT7.25x7.1CH	7.25 ± 0.15	3.55 ± 0.10	2.90 ± 0.10	5.93 ± 0.13	2.90 ± 0.15	5.70 ± 0.40	1.80 ± 0.20	1.43 ± 0.05	1
POT7.35x7CH	7.35 ± 0.15	3.50 ± 0.10	3.00 ± 0.10	6.00 ± 0.15	2.50 ± 0.10	—	2.10 ± 0.30	1.00 ± 0.10	3
POT9x5	9.15 ± 0.15	2.65 ± 0.05	3.80 ± 0.10	7.62 ^{+0.13} _{-0.12}	1.87 ^{+0.08} _{-0.07}	5.65 ± 0.15	2.10 ± 0.30	—	1
POT9x5CH	9.15 ± 0.15	2.65 ± 0.05	3.80 ± 0.10	7.62 ^{+0.13} _{-0.12}	1.87 ^{+0.08} _{-0.07}	5.65 ± 0.15	2.10 ± 0.30	1.95 ± 0.05	1
POT9x5ACH	9.00 ± 0.15	3.50 ± 0.10	3.80 ± 0.10	7.63 ± 0.13	2.50 ± 0.05	5.65 ± 0.15	2.10 ± 0.30	2.00 ^{+0.10} _{-0.00}	1
POT11x7	11.10 ± 0.20	3.30 ^{+0.08} _{-0.07}	4.60 ± 0.10	9.20 ± 0.20	2.30 ^{+0.08} _{-0.07}	6.80 ± 0.25	2.20 ± 0.30	—	1
POT11x7CH	11.10 ± 0.22	3.30 ^{+0.08} _{-0.07}	4.60 ± 0.10	9.20 ± 0.20	2.30 ^{+0.08} _{-0.07}	6.80 ± 0.25	2.20 ± 0.30	2.10 ± 0.10	1
POT14x8	14.00 ± 0.25	4.18 ± 0.08	5.99max	11.60min	2.79min	9.50 ± 0.60	3.30 ± 0.60	—	1
POT14x8CH	14.00 ± 0.25	4.18 ± 0.08	6.09max	11.60min	2.79min	9.50 ± 0.60	3.30 ± 0.60	3.10 ± 0.07	1
POT18x10.5	18.00 ± 0.40	5.25 ± 0.10	7.40 ± 0.15	15.20 ± 0.25	3.80 ± 0.15	11.55 ± 0.30	4.15 ± 0.30	—	1
POT18x11CH	17.90 ± 0.30	5.30 ^{+0.08} _{-0.07}	7.40 ± 0.15	15.25 ± 0.25	3.80 ± 0.10	11.55 ± 0.30	3.20 ± 0.30	3.02 ± 0.07	1
POT18x11ACH	17.90 ± 0.30	5.30 ^{+0.08} _{-0.07}	7.40 ± 0.15	15.25 ± 0.25	3.80 ± 0.10	11.55 ± 0.30	3.80 ± 0.30	—	1
POT24.3x17.6CH	24.30 ± 0.50	8.90 ^{+0.00} _{-0.45}	10.88 ± 0.30	20.83 ± 0.50	5.90 ^{+0.40} _{-0.00}	16.80 ± 0.35	3.95 ± 0.25	5.51 ± 0.20	1
POT35.5x22CH	35.50 ± 0.50	10.90 ± 0.20	15.95 ± 0.25	30.30 ± 0.40	7.50 ± 0.20	26.80 ± 0.50	4.00 ± 0.30	5.65 ± 0.15	1
POT69x28CH	69.00 ± 1.20	14.00 ± 0.20	29.00 ± 0.50	58.40 ^{+1.00} _{-0.80}	9.30 ± 0.30	48.20 ± 0.80	10.50 ± 0.50	8.50 ± 0.50	1

* POT Core = 1 PC POT Core + 1 PC POT Core.

■ EFFECTIVE PARAMETERS

CORES	EFFECTIVE PARAMETERS				
	C _i (mm ⁻¹)	Le(mm)	Ae(mm ²)	Ve(mm ³)	Wt(g/set)
POT3.35x2.6	3.68	4.80	1.30	6.25	0.07
POT5.5x8	3.17	16.48	5.19	85.49	0.48
POT7.25x7.1CH	2.29	14.51	6.34	91.96	0.98
POT7.35x7CH	1.73	14.16	8.17	115.64	0.87
POT9x5	1.06	13.52	12.76	172.52	0.94
POT9x5CH	1.25	12.20	9.80	119.56	0.86
POT9x5ACH	1.39	14.96	10.77	161.00	1.30
POT11x7	0.86	16.30	19.00	309.00	2.12
POT11x7CH	0.96	15.50	16.20	251.00	2.00
POT14x8	0.70	21.00	29.90	628.00	3.60
POT14x8CH	0.79	19.80	25.00	495.00	3.14
POT18x10.5	0.57	26.32	46.25	1217.30	7.20
POT18x11CH	0.60	25.80	43.30	1120.00	6.66
POT18x11ACH	0.78	27.20	43.10	1172.32	6.60
POT24.3x17.6CH	0.51	52.73	103.34	5448.97	19.90
POT35.5x22CH	0.30	70.47	237.15	16712.00	83.90
POT69x28CH	0.13	78.49	624.89	49045.32	317.05

■ ELECTRICAL CHARACTERISTICS

CORES	AL ± 25% (nH/N ²)						AL + 40% - 30% (nH/N ²)	
	P4	P47	P5	N4	N42	A05	A10(L)	A121(L)
POT3.35x2.6					110 (N43)			
POT5.5x8	560							
POT7.25x7.1CH	660							
POT7.35x7CH	860							
POT9x5	1300			1300	1600		5800 ± 30%	
POT9x5CH	1200	1300	1100	1200	1350			
POT9x5ACH	1100							
POT11x7	2000		1800	2000	2310	2890		10000
POT11x7CH	1800	2000	1600	1800		2500		
POT14x8	2400	2700	2000	2400	2620	3500		
POT14x8CH	2000	2100	1700	2000	2300	3500+30%-25%	9800	
POT18x10.5					3500			
POT18x11CH	2850	3600	2430	2850	4155	4600+30%-25%	12600	
POT18x11ACH	2850							
POT24.3x17.6CH				5200				
POT35.5x22CH	7500							
POT69x28CH	15000							

Remark:

1. AL Value Testing Condition : 10kHz, 50mV, 100Ts. If testing condition is different from ACME's, please specify upon request & ordering.
2. Gapped core is available, please specify upon request & ordering. ACME's standard gapped core set is a combination of one gapped core and one ungapped core. If gapping on both pcs to make a set is needed, please specify upon request & ordering.
3. L : Mirror Finished Lapping. Please specify upon request & ordering by adding "L" at the end of Core Size if you need.

Type : RM/LM Cores

Ordering Code:

P4

RM5

G□

Shape:

Material
材質

Core Size
品名

Gapped AL Value

Type:1

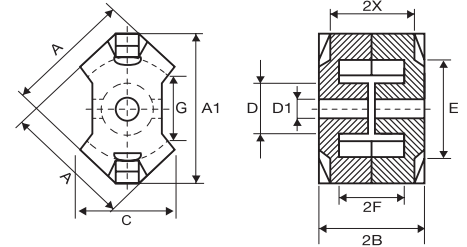

Type:2

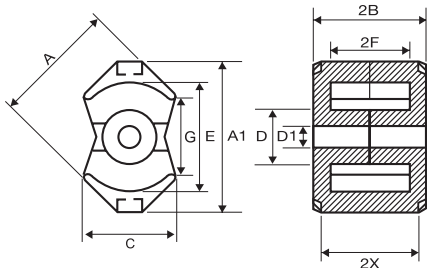

Type:3

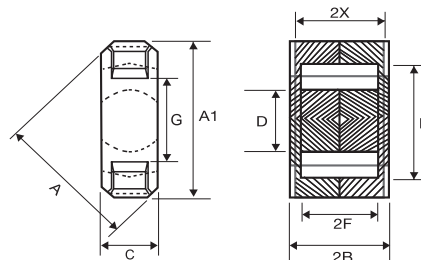

Type:4

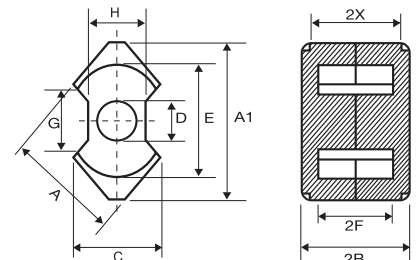

Type:5

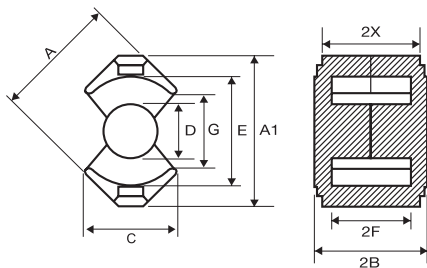

Type:6

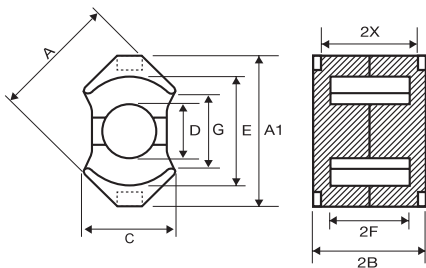

Type:7

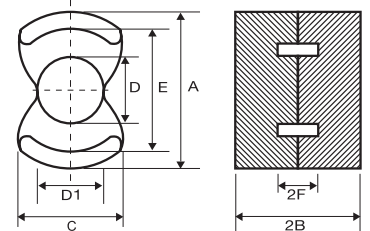

■ DIMENSIONS

CORES	DIMENSIONS (mm)											Type
	A	A ₁	B	C	D ^(ø)	D ₁ ^(ø)	E	F	G	H	2X	
RM4	9.60 ± 0.20	10.80 ± 0.20	5.20 ± 0.05	6.40 ± 0.20	3.80 ± 0.10	—	8.15 ± 0.15	3.60 ± 0.10	5.80min	—	9.00 ± 0.25	1
RM5	12.05 ± 0.25	14.30 ± 0.30	5.20 ± 0.10	9.55 ± 0.25	4.80 ± 0.10	—	10.40 ± 0.20	3.35 ± 0.20	6.00min	—	9.10 ± 0.25	1
RM6	14.40 ± 0.30	17.60 ± 0.30	6.20 ± 0.10	10.47 ± 0.25	6.30 ± 0.10	—	12.64 ± 0.25	4.20 ± 0.20	8.50min	—	10.40 ± 0.25	6
RM6CH	14.40 ± 0.30	17.60 ± 0.30	6.20 ± 0.10	10.47 ± 0.25	6.30 ± 0.10	3.00 ± 0.10	12.64 ± 0.25	4.20 ± 0.20	8.50min	—	10.40 ± 0.25	2
RM6C	17.60 ± 0.30	14.40 ± 0.30	4.50 ± 0.10	5.15 ± 0.15	6.30 ± 0.10	—	12.64 ± 0.25	2.35 ± 0.10	11.50min	—	3.48 ± 0.15	3
RM6F	14.40 ± 0.30	16.80 ± 0.30	5.50 ± 0.10	8.00 ± 0.30	6.30 ± 0.15	—	12.65 ± 0.25	3.40 ± 0.15	9.10min	—	—	4
RM6H	14.40 ± 0.30	17.60 ± 0.30	4.15 ± 0.10	8.00 ± 0.30	6.30 ± 0.10	—	12.65 ± 0.25	2.10 ± 0.10	9.15 ± 0.30	—	—	2
RM7A	16.85 ± 0.35	19.90 ± 0.40	6.70 ± 0.10	11.43 ± 0.30	7.10 ± 0.15	—	15.10 ± 0.35	4.32 ± 0.15	11.00min	—	12.50 ± 0.30	5
RM7E	19.90 ± 0.40	16.85 ± 0.30	6.80 ± 0.20	7.10 ± 0.15	7.10 ± 0.15	—	15.10 ± 0.35	4.42 ± 0.30 / 0.20	11.00min	—	—	5
RM8	19.35 ± 0.35	22.76 ± 0.45	8.20 ± 0.15	15.45 ± 0.30	8.40 ± 0.15	—	17.30 ± 0.30	5.60 ± 0.20	9.80min	—	14.40 ± 0.25	1
RM8CH	19.35 ± 0.35	22.76 ± 0.45	8.20 ± 0.15	15.45 ± 0.30	8.40 ± 0.15	4.50 ± 0.15	17.30 ± 0.30	5.60 ± 0.20	9.80min	—	14.40 ± 0.25	1
RM8A	19.35 ± 0.35	22.76 ± 0.45	8.20 ± 0.15	15.45 ± 0.30	8.40 ± 0.15	—	17.30 ± 0.30	5.60 ± 0.20	9.80min	—	14.40 ± 0.25	6
RM10	24.15 ± 0.55	27.80 ± 0.65	9.30 ± 0.15	19.85 ± 0.30	10.65 ± 0.20	—	21.65 ± 0.45	6.40 ± 0.20	12.40min	—	16.30 ± 0.25	6
RM10B	24.20 ± 0.30	28.20 ± 0.30	9.30 ± 0.10	18.05 ± 0.30	10.65 ± 0.15	—	22.00 ± 0.30	6.50 ± 0.15	14.20min	13.25 ± 0.25	—	4
RM12	29.20 ± 0.60	36.85 ± 0.75	12.25 ± 0.10	—	12.60 ± 0.20	—	25.45 ± 0.55	8.55 ± 0.15	13.40min	15.85 ± 0.25	22.10 ± 0.25	4
LM8A	23.00 ± 0.45	—	8.00 ± 0.15	17.71ref	9.00 ± 0.10 / -0.20	12.80 ± 0.10 / -0.20	18.10 ± 0.40	5.30 ± 0.20	—	—	—	7

* RM 6,8 CAN ALSO BE MANUFACTURED WITH CENTER HOLES. (CH)



■ EFFECTIVE PARAMETERS (PER SET)

CORES	EFFECTIVE PARAMETERS					
	C _i (mm ⁻¹)	Le(mm)	Ae(mm ²)	Amin(mm ²)	Ve(mm ³)	Wt(g/set)
RM4	1.70	22.00	13.00	11.30	286.00	1.68
RM5	0.93	22.10	23.80	18.10	526.00	3.28
RM6	0.78	28.60	36.60	31.00	1050.00	5.44
RM6CH (With Center Hole)	0.86	26.90	31.30	–	840.00	4.96
RM6C	0.49	20.89	42.59	–	889.99	2.74
RM6F	0.85	26.66	31.20	31.17	881.36	4.72
RM6H	0.57	20.70	36.60	31.17	757.62	3.80
RM7A	0.60	30.27	50.74	–	1535.91	7.05
RM7E	0.90	35.60	39.60	39.59	1409.76	7.12
RM8	0.59	38.89	62.14	55.00	2416.62	12.40
RM8CH (With Center Hole)	0.67	35.10	52.00	–	1840.00	11.02
RM8A	0.59	38.00	64.00	–	2432.00	12.60
RM10	0.46	44.60	96.60	89.10	4310.00	21.88
RM10B	2.20	44.28	97.27	–	4307.12	20.94
RM12	0.42	60.60	144.00	124.70	8752.00	45.78
LM8A	0.45	40.50	90.77	–	3645.00	17.60

■ ELECTRICAL CHARACTERISTICS

CORES	AL + 30% - 20% (nH/N ²)									AL + 40% - 30% (nH/N ²)	
	P4	P47	P48	P5	P51	N4	N42	A05	A05(L)	A10(L)	A121(L)
RM4	1100	1230 ± 25%		1000 ± 25%		1000	1400 ± 25%	1700	2870	5050	
RM5	2000	2200 ± 25%		1860 ± 25%	1290 ± 25%	1850	2100 ± 25%	3500	5700	6700	7500min
RM6	2400	2850 ± 25%		2300 ± 25%	1650 ± 25%	2380	3000 ± 25%	4300	7300 ± 25%	8600	7490min
RM6CH	2170							3900	6620 ± 25%	7800	
RM6C	2440 ± 25%										
RM6F		2400									
RM6H			2200								
RM7A		2400 (P41)									
RM7E	2600(P41)										
RM8	3300	3800 ± 25%	3300	2770	2200	2800		5700	9700 ± 25%	12500	
RM8CH	2900					2900		5020	8540 ± 25%	11010	
RM8A	3300										
RM10	4200			3650 ± 25%				7600	12750 ± 25%	16000	
RM10B	4200	5040								16000	
RM12	5550 ± 25%										
LM8A	4500										

Remark:

1. AL Value Testing Condition : 10kHz, 50mV, 100Ts. If testing condition is different from ACME's, please specify upon request & ordering.
2. Gapped core is available, please specify upon request & ordering. ACME's standard gapped core set is a combination of one gapped core and one ungapped core. If gapping on both pcs to make a set is needed, please specify upon request & ordering.
3. L : Mirror Finished Lapping. Please specify upon request & ordering by adding "L" at the end of Core Size if you need.

■ EFFECTIVE PARAMETERS

CORES	EFFECTIVE PARAMETERS				
	$C_t(\text{mm}^{-1})$	$L_e(\text{mm})$	$A_e(\text{mm}^2)$	$V_e(\text{mm}^3)$	$W_t(\text{g/set})$
PEE14	1.43	20.70	14.50	300.00	1.40
PEI14	1.16	16.70	14.50	240.00	1.22
PEE18	0.62	24.30	39.50	960.00	4.80
PEI18	0.50	20.30	40.80	830.00	4.29
PEE22	0.41	32.50	78.50	2550.00	13.00
PEI22	0.33	26.10	78.50	2040.00	10.57
PEI31.75	0.27	35.10	130.00	4563.00	23.50
PEE33.6	0.73	32.68	44.83	1465.04	10.50
PEE38.1	0.27	52.51	195.38	10260.00	51.20
PEI38.1	0.22	43.58	194.58	8477.54	43.15

■ ELECTRICAL CHARACTERISTICS

CORES	$AL \pm 25\% (\text{nH/N}^2)$									
	P4	P41	P42	P46	P47	P48	P5	P51	P52	N42
PEE14	1350	1300	1140	1620	1530		1150			
PEI14	1250	1220		1630			1150			
PEE18	3300	3280	2280	3610	3400		2850	1990		
PEI18	3900	3810		4600	4200		3300	2350		
PEE22	5400			5980				3145		
PEI22	6450	6280	4550	6880	6200		5500	3740		
PEI31.75		7000								
PEE33.6	3000									
PEE38.1	7520 (ref)									
PEI38.1	8580 (ref)									

Remark:

1. AL Value Testing Condition : 10kHz, 50mV, 100Ts. If testing condition is different from ACME's, please specify upon request & ordering.
2. Gapped core is available, please specify upon request & ordering. ACME's standard gapped core set is a combination of one gapped core and one ungapped core. If gapping on both pcs to make a set is needed, please specify upon request & ordering.

Type : PQ Cores

Ordering Code:

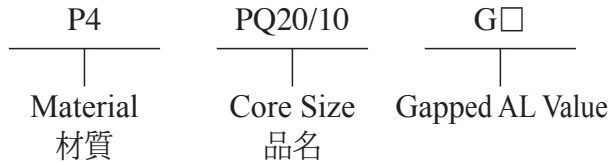

Shape:

Type:1

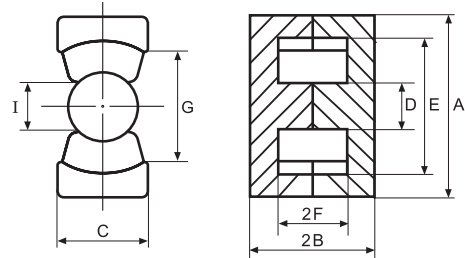

Type:2

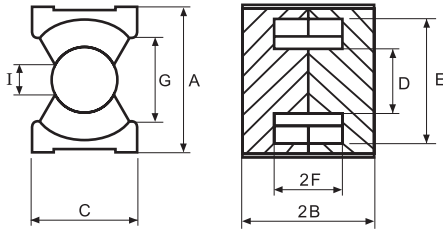

Type:3

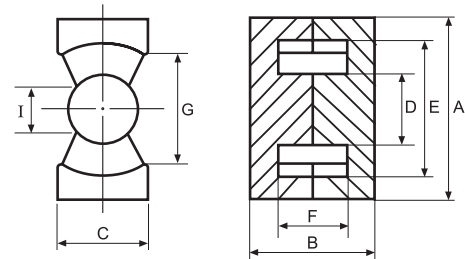

Type:4

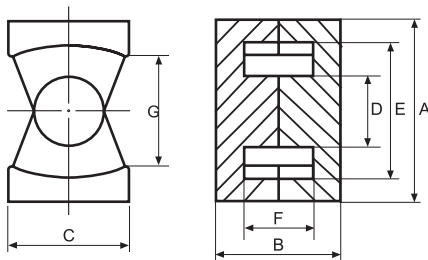

Type:5

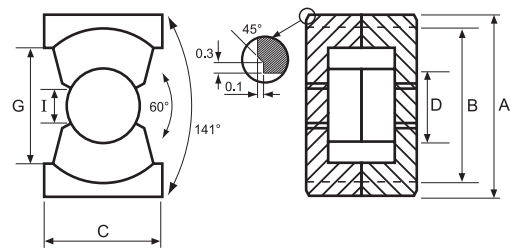

■ DIMENSIONS

CORES	DIMENSIONS (mm)								Type
	A	B	C	D	E	F	G	I	
PQ20/10	20.50 ± 0.40	5.10 ± 0.10	14.00 ± 0.40	8.70 ± 0.30	18.00 ± 0.40	2.15 ± 0.15	12.00min	4.00min	1
PQ20/16	20.50 ± 0.40	8.10 ± 0.10	14.00 ± 0.40	8.70 ± 0.30	18.00 ± 0.40	5.15 ± 0.15	12.00min	4.00min	1
PQ20/20	20.50 ± 0.40	10.10 ± 0.10	14.00 ± 0.40	8.70 ± 0.30	18.00 ± 0.40	7.15 ± 0.15	12.00min	4.00min	1
PQ26/20	26.50 ± 0.45	10.08 ^{+0.12} _{-0.13}	19.00 ± 0.45	12.00 ± 0.20	22.50 ± 0.45	5.75 ± 0.15	15.50min	5.25min	1
PQ26/25	26.50 ± 0.45	12.38 ^{+0.12} _{-0.13}	19.00 ± 0.45	12.00 ± 0.20	22.50 ± 0.45	8.05 ± 0.15	15.50min	5.25min	1
PQ26B/14.38	26.50 ± 0.45	7.19 ± 0.20	19.00 ± 0.35	12.00 ± 0.20	22.50 ± 0.45	2.86 ± 0.20	15.50min	6.08 ± 0.20	3
PQ27/15	27.30 ± 0.46	7.50 ± 0.15	19.00 ± 0.45	12.00 ± 0.20	22.50 ± 0.46	3.15 ± 0.15	15.50min	—	2
PQ27/20	27.30 ± 0.46	10.10 ± 0.12	19.00 ± 0.45	12.00 ± 0.20	22.50 ± 0.46	5.75 ± 0.15	15.50min	6.00min	2
PQ27A/20	27.30 ± 0.46	10.10 ± 0.13	19.00 ± 0.45	12.00 ± 0.20	23.05min	5.75 ± 0.15	16.80min	6.00min	2
PQ32A/25	32.00 ± 0.50	12.55 ± 0.25	22.00 ± 0.50	13.30 ± 0.25	27.50 ± 0.50	8.25 ± 0.20	19.75min	—	3
PQ32B/20	32.00 ± 0.50	10.28 ± 0.20	22.00 ± 0.50	13.30 ± 0.20	27.50 ± 0.50	5.75 ± 0.20	19.50min	6.00ref	5
PQ32B/25	32.00 ± 0.50	12.55 ± 0.20	22.00 ± 0.50	13.30 ± 0.20	27.50 ± 0.50	8.05 ± 0.20	19.50min	—	5
PQ32B/30	32.00 ± 0.50	15.25 ± 0.13	22.00 ± 0.50	13.30 ± 0.20	27.50 ± 0.50	10.75 ± 0.15	19.50min	—	3
PQ32D/26	32.00 ± 0.50	13.00 ± 0.25	21.30 ^{+0.20} _{-0.50}	13.20 ± 0.25	27.00 ± 0.50	8.60 ± 0.25	20.00min	7.45 ± 0.20	3
PQ32H/25	32.00 ± 0.50	12.50 ± 0.20	22.00 ± 0.40	13.45 ± 0.25	27.50 ± 0.50	8.10 ± 0.20	19.75min	7.45 ± 0.20	1
PQ35A/12.2	35.00 ± 0.65	6.10 ± 0.15	18.60 ± 0.50	13.00 ± 0.20	29.70 ± 0.60	3.40 ± 0.15	24.72ref	—	4
PQ35.1	35.10 ± 0.60	15.00 ± 0.15	26.00 ± 0.50	14.35 ± 0.25	24.00 ± 0.50	10.13 ± 0.15	32.00 ± 0.50	5.60min	1
PQ35/35	35.10 ± 0.60	17.40 ± 0.30	26.00 ± 0.50	14.35 ± 0.35	31.00min	12.50 ± 0.40	23.50min	5.20min	1
PQ38	38.00 ± 0.50	5.30 ± 0.15	21.32 ± 0.40	14.30 ± 0.25	32.80 ± 0.50	2.45 ± 0.15	25.84min	—	4
PQ40	40.30 ± 0.40	20.50 ± 0.30	28.00 ± 0.40	15.00 ± 0.30	35.70min	15.30 ± 0.30	28.10min	—	3



■ EFFECTIVE PARAMETERS

CORES	EFFECTIVE PARAMETERS				
	C _i (mm ⁻¹)	Le(mm)	Ae(mm ²)	Ve(mm ³)	Wt(g/set)
PQ20/10	0.42	25.61	61.32	1570.41	9.40
PQ20/16	0.61	37.60	61.90	2330.00	12.94
PQ20/20	0.74	45.40	62.00	2790.00	15.48
PQ26/20	0.37	45.00	121.00	5470.00	28.40
PQ26/25	0.45	54.30	120.00	6530.00	30.00
PQ26B/13.8	0.27	32.60	119.00	3878.00	23.32
PQ27/15	0.29	33.96	118.34	4018.83	22.28
PQ27/20	0.36	43.35	119.93	5198.80	30.30
PQ27A/20	0.39	46.30	118.00	5463.40	28.40
PQ32A/25	0.44	74.60	165.80	12368.68	47.00
PQ32B/20	0.31	45.83	146.42	6710.43	38.38
PQ32B/25	0.39	55.41	140.52	7786.21	46.68
PQ32B/30	0.46	74.60	158.10	11794.26	55.10
PQ32D/26	0.50	44.60	89.10	4310.00	46.40
PQ32H/25	0.38	58.50	153.10	8956.00	47.70
PQ35A/12.2	0.40	42.96	108.28	4651.80	12.00
PQ35.1	0.39	64.72	165.17	10689.80	64.32
PQ35/35	0.45	74.11	163.39	12108.88	73.88
PQ38	0.57	48.54	85.03	4127.36	26.96
PQ40	0.52	93.57	180.20	16860.00	95.50

■ ELECTRICAL CHARACTERISTICS

CORES	AL ± 25% (nH/N ²)									
	P4	P41	P42	P46	P47	P48	P5	P51	P52	N42
PQ20/10			4000		5690					
PQ20/16	3880			4270	4000		3250			
PQ20/20	3300	3260		3740	3480		2800	1880		
PQ26/20	6170	5900		7600	6300		5300			
PQ26/25	5250	5000		6500	5600					
PQ26B/13.8				8000(P45)						
PQ27/15					7800					
PQ27/20	5740	5560								
PQ27A/20					7500					
PQ32A/25					6200					
PQ32B/20	6300									
PQ32B/25		4800			6300					
PQ32B/30					6000					
PQ32D/26	5200									
PQ32H/25				6300(P45)						
PQ35A/12.2					6000					
PQ35.1					7800					
PQ35/35	5100									
PQ38					5500					
PQ40	4500									

Remark:

1. AL Value Testing Condition : 10kHz, 50mV, 100Ts. If testing condition is different from ACME's, please specify upon request & ordering.
2. Gapped core is available, please specify upon request & ordering. ACME's standard gapped core set is a combination of one gapped core and one ungapped core. If gapping on both pcs to make a set is needed, please specify upon request & ordering.

Type : EE/EEL Cores

Ordering Code:

Shape:

P4	EE4.2	G□
Material	Core Size	Gapped AL Value
材質	品名	

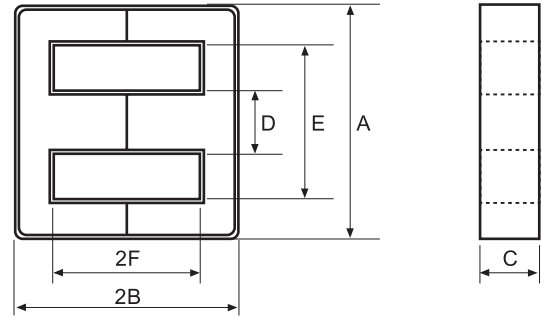

■ DIMENSIONS AND EFFECTIVE PARAMETERS

CORES	DIMENSIONS (mm)						EFFECTIVE PARAMETERS				
	A	B	C	D	E	F	C1(mm ⁻¹)	Le(mm)	Ae(mm ²)	Ve(mm ³)	Wt(g/set)
EE4.2	4.35 ± 0.10	1.35 ± 0.05	1.35 ± 0.10	1.20 ± 0.10	3.15 ± 0.10	0.85 ± 0.05	4.71	7.04	1.49	10.49	0.11
EE5.0	5.25 ± 0.10	2.66 ± 0.07	1.95 ± 0.05	1.35 ± 0.05	3.80min	1.98 ± 0.07	4.70	12.50	2.66	33.30	0.17
EE5.0C	5.25 ± 0.10	3.00 ± 0.15	1.40 ± 0.10	1.35 ± 0.10	3.90 ^{+0.20} _{-0.10}	2.35 ± 0.15	7.50	14.03	1.87	26.25	0.13
EE5.0D	5.25 ± 0.10	2.66 ± 0.07	1.95 ± 0.05	1.35 ± 0.05	3.80min	1.98 ± 0.07	4.64	12.53	2.70	33.83	0.16
EE6.17	6.17 ± 0.13	2.85 ± 0.05	1.96 ± 0.05	1.35 ± 0.05	3.70 ± 0.10	1.93 ^{+0.08} _{-0.07}	3.71	12.29	3.31	40.70	0.24
EE6.2	6.18 ± 0.20	2.85 ± 0.08	1.95 ± 0.10	1.35 ± 0.10	3.70 ± 0.10	1.90 ± 0.10	3.67	12.20	3.33	40.57	0.26
EE6.3	6.30 ± 0.25	2.82 ^{+0.08} _{-0.07}	2.00 ± 0.15	1.32 ^{+0.08} _{-0.07}	3.60 ^{+0.20} _{-0.00}	1.92 ^{+0.08} _{-0.07}	3.64	12.13	3.33	40.39	0.28
EE6.3/1.2	6.30 ^{+0.10} _{-0.20}	3.25 ^{+0.15} _{-0.10}	1.20 ^{+0.10} _{-0.15}	1.65 ^{+0.10} _{-0.15}	4.30 ^{+0.15} _{-0.10}	2.10 ^{+0.15} _{-0.10}	6.14	14.08	2.29	32.28	0.16
EE6.6	6.60 ± 0.15	3.25 ± 0.10	1.15 ± 0.10	1.65 ± 0.05	4.30min	2.30 ± 0.05	6.74	14.63	2.17	31.75	0.07
EE8.0/5.0	8.00 ± 0.15	5.00 ± 0.08	5.00 ± 0.15	2.90 ± 0.10	5.31 ± 0.15	3.50 ± 0.08	1.48	20.93	14.16	296.37	1.50
EE8.1	8.10 ± 0.20	7.00 ± 0.15	3.70 ± 0.15	1.85 ± 0.15	6.10 ± 0.20	5.75 ± 0.15	4.12	30.45	7.39	225.03	1.16
EE8.3A	8.30 ± 0.20	4.00 ± 0.10	3.90 ± 0.10	2.15 ± 0.15	6.30 ± 0.20	3.00 ± 0.10	2.41	19.33	7.98	154.42	0.76
EE8.3A-1	8.30 ± 0.20	4.00 ± 0.10	3.90 ± 0.10	2.15 ± 0.15	6.30 ± 0.20	3.00 ± 0.10	2.41	19.33	7.98	154.42	0.76
EE8.3B	8.30 ± 0.30	4.15 ± 0.10	1.85 ± 0.15	1.85 ± 0.15	6.00min	3.13 ± 0.10	4.53	19.95	3.67	73.22	0.36
EE8.3B-1	8.30 ± 0.30	4.00 ± 0.10	1.85 ± 0.15	1.85 ± 0.15	6.00min	3.00 ± 0.10	5.32	19.42	3.65	70.89	0.35
EE8.3D	8.30 ± 0.20	4.00 ± 0.10	3.90 ± 0.10	1.85 ± 0.15	6.15 ± 0.20	3.00 ± 0.10	2.50	19.37	7.74	149.92	0.76
EE8.6	8.60 ± 0.30	4.65 ± 0.10	3.65 ± 0.15	1.85 ± 0.20	6.30min	3.55min	2.99	22.02	7.37	162.29	0.87
EE8.8	8.80 ± 0.20	6.00 ± 0.20	2.80 ± 0.10	2.80 ± 0.10	6.00 ± 0.15	4.50 ± 0.10	3.23	25.74	7.95	204.60	1.32
EE8.8A	9.00 ± 0.40	4.00 ± 0.10	1.90 ± 0.10	1.90 ± 0.10	5.20 ± 0.15	2.19 ± 0.16	3.13	15.58	4.98	77.65	0.52
EE8.8B	9.00 ± 0.40	4.10 ± 0.10	1.90 ± 0.10	1.90 ± 0.10	5.20min	2.29 ± 0.16	3.34	16.42	4.91	80.70	0.54
EEL8.8	8.80 ± 0.20	8.50 ± 0.10	2.80 ± 0.10	2.80 ± 0.10	6.00 ± 0.15	7.20 ± 0.10	4.67	36.22	7.75	280.70	1.41
EE9.0	9.00 ± 0.20	6.15 ± 0.20	2.80 ± 0.10	2.80 ± 0.10	6.30 ± 0.15	4.65 ± 0.10	3.39	26.58	7.83	208.23	1.06
EE9.0A	9.00 ± 0.40	5.50 ± 0.10	2.35 ± 0.15	2.35 ± 0.10	5.75min	3.75 ± 0.15	3.42	22.71	6.64	150.77	0.82
EE9.3	9.30 ± 0.20	6.20 ^{+0.15} _{-0.10}	2.80 ± 0.10	2.80 ± 0.10	6.60 ± 0.10	4.70 ^{+0.15} _{-0.10}	3.47	27.16	7.84	212.87	1.04
EE10	10.20 ± 0.20	5.70 ± 0.10	4.75 ± 0.15	2.45 ± 0.15	7.70min	4.20 ± 0.15	2.13	26.00	12.00	323.00	1.60
EE10/10	10.20 ± 0.20	5.50 ± 0.10	9.85 ± 0.15	2.40 ± 0.15	7.80 ± 0.20	4.30 ± 0.10	1.11	26.36	23.64	623.10	3.32
EE10A	10.00 ± 0.20	6.60 ± 0.20	2.70 ± 0.10	2.80 ± 0.10	7.30 ± 0.15	5.00 ± 0.15	3.80	29.08	7.66	222.75	1.12
EE10.2	10.20 ± 0.20	4.50 ± 0.10	4.75 ± 0.15	2.45 ± 0.15	8.75 ± 0.20	3.25 ± 0.10	2.18	20.39	9.34	190.44	1.24
EE11	11.00 ± 0.20	2.60 ± 0.10	4.50 ± 0.20	2.00 ± 0.20	9.00 ± 0.20	1.45 ± 0.10	1.67	16.11	9.65	155.46	0.96
EE12	12.00 ± 0.15	3.20 ± 0.10	6.50 ± 0.10	3.10 ± 0.10	8.90 ± 0.15	1.80 ± 0.10	0.92	17.60	19.18	337.57	1.70



■ ELECTRICAL CHARACTERISTICS

CORES	AL ± 25% (nH/N²)						AL ± 30% (nH/N²)					
	P4	P41	P46	P47	P48	P5	N42	A05	A07	A10(L)	A121(L)	A151(L)
EE4.2				190		130		290				
EE5.0	280	270	350			250	360	400	440	980min	1080min	1350min
EE5.0C	220	215										
EE5.0D	280		350	330						980min		1350min
EE6.17		405										
EE6.2											1600min	
EE6.3	370					340		560	620	1800	2100	
EE6.3/1.2	270											
EE6.6	100											
EE8.0/5.0	1220											
EE8.1									990			
EE8.3A	750					600	990	1100	1290	3000	3300	3800
EE8.3A-1									2000+40%-30%			
EE8.3B	350		400					510	580	1800		1980
EE8.3B-1	360	350		400					600	1800		
EE8.3D	750							1090		3000	3700	
EE8.6	680								1140			
EE8.8	680		740						1200	2740	3180	3680
EE8.8A	470	460	580						870		2720	
EE8.8B		460		470								
EEL8.8									950			
EE9.0	620									2420		
EE9.0A											3300	
EE9.3	540											
EE10	940	900	1170	1100		750	1250	1500	1750	4190	3332min	
EE10/10	1850			2150								
EE10A	530								1050	2200		
EE10.2								1200				
EE11	1060(ref)											
EE12	2100											

Remark:

1. AL Value Testing Condition : 10kHz, 50mV, 100Ts. If testing condition is different from ACME's, please specify upon request & ordering.
2. Gapped core is available, please specify upon request & ordering. ACME's standard gapped core set is a combination of one gapped core and one ungapped core. If gapping on both pcs to make a set is needed, please specify upon request & ordering.
3. L : Mirror Finished Lapping. Please specify upon request & ordering by adding "L" at the end of Core Size if you need.

Type : EE/EEL Cores

Ordering Code:

Shape:

P4
EE19
G□
 Material Core Size Gapped AL Value
 材質 品名

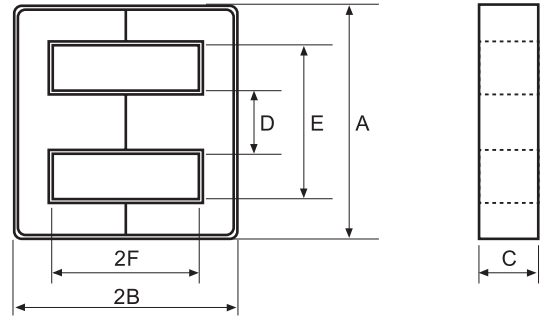

■ DIMENSIONS AND EFFECTIVE PARAMETERS

CORES	DIMENSIONS (mm)						EFFECTIVE PARAMETERS				
	A	B	C	D	E	F	C1(mm ⁻¹)	Le(mm)	Ae(mm ²)	Ve(mm ³)	Wt(g/set)
EE12.8-1	12.80 ± 0.25	12.00 ± 0.15	3.50 ± 0.13	3.65 ± 0.10	8.80 ± 0.25	10.00 ± 0.15	3.81	51.20	13.43	687.80	3.38
EE12.9/10	12.95 ± 0.30	6.50 ^{+0.00} / _{-0.15}	9.80 ± 0.20	3.55 ± 0.15	9.15 ± 0.25	4.50 ^{+0.30} / _{-0.00}	0.80	29.57	36.80	1088.00	5.34
EE12.9A	12.90 ± 0.30	6.85 ± 0.15	1.80 ± 0.20	6.00 ± 0.10	9.40 ± 0.25	4.50 ± 0.30	3.54	27.43	7.75	212.58	1.28
EE13	13.00 ± 0.30	6.00 ± 0.20	6.15 ± 0.15	2.95 ^{+0.00} / _{-0.35}	10.50 ± 0.30	4.65 ± 0.15	1.64	28.00	17.00	480.00	2.38
EE13/3.55	13.13 ± 0.20	7.13 ± 0.20	3.55 ± 0.10	3.53 ± 0.15	9.00min	5.11 ± 0.15	2.34	31.93	13.66	436.16	2.18
EEL13	13.00 ± 0.20	8.10 ± 0.15	3.00 ± 0.15	3.40 ± 0.15	9.40 ± 0.20	6.30 ± 0.15	3.48	36.75	10.56	387.97	1.86
EEL13/3.1	13.00 ± 0.20	8.10 ± 0.15	3.10 ± 0.15	3.40 ± 0.20	9.40 ± 0.20	6.30 ± 0.15	3.37	36.75	10.91	400.90	2.08
EEL14	14.05 ± 0.25	15.75 ± 0.15	3.50 ± 0.15	4.55 ± 0.15	9.25 ± 0.20	12.25 ± 0.15	3.64	62.06	17.06	1058.68	5.42
EEL14A	14.00 ± 0.25	13.15 ^{+0.15} / _{-0.15}	2.70 ± 0.15	4.00 ± 0.10	10.00 ± 0.25	10.95 ± 0.15	5.14	56.34	10.96	617.49	3.00
EEL14.15	14.15 ± 0.25	7.70 ± 0.15	4.20 ± 0.20	4.28 ± 0.15	10.55 ± 0.25	5.30 ± 0.15	1.99	33.93	17.03	577.83	3.12
EEL14.6A	14.60 ± 0.30	10.95 ± 0.10	3.60 ^{+0.10} / _{-0.20}	4.00 ± 0.15	10.60 ± 0.30	8.95 ± 0.15	3.30	48.02	14.54	698.21	3.30
EE15	15.00 ± 0.30	7.40 ± 0.20	2.30 ^{+0.10} / _{-0.12}	3.70 ± 0.20	9.20 ± 0.30	5.40 ± 0.20	3.36	32.84	9.77	321.03	1.77
EEL15.4A	15.40 ± 0.30	9.10 ± 0.15	3.30 ^{+0.10} / _{-0.15}	3.40 ± 0.20	11.80 ± 0.30	7.35 ^{+0.15} / _{-0.10}	3.75	43.27	11.54	499.23	2.48
EE16	16.00 ± 0.30	7.30 ± 0.20	4.80 ± 0.20	4.00 ± 0.20	11.70min	5.20 ± 0.20	1.81	35.23	19.49	686.55	3.20
EE16A	16.00 ± 0.30	7.15 ± 0.15	6.80 ± 0.20	3.17 ^{+0.18} / _{-0.17}	12.50min	5.50 ± 0.10	1.48	35.50	24.00	852.00	3.96
EE16D	16.00 ± 0.30	7.90 ± 0.15	4.80 ± 0.15	4.00 ± 0.15	12.10 ± 0.30	5.70 ± 0.15	1.91	35.10	19.20	675.00	3.70
EEL16	16.00 ± 0.30	12.40 ± 0.20	4.80 ± 0.20	4.00 ± 0.20	11.60min	10.20 ± 0.20	2.72	55.00	20.00	1116.00	5.28
EE16.5	16.50 ± 0.30	6.00 ± 0.10	7.10 ± 0.15	4.60 ± 0.10	11.50 ± 0.20	3.65 ± 0.10	0.86	28.93	33.75	976.39	5.08
EE16.5-1	16.48 ± 0.30	6.50 ^{+0.25} / _{-0.30}	9.00 ± 0.20	3.03 ± 0.15	9.78min	4.20 ± 0.20	0.79	28.55	35.94	1026.09	6.86
EE16.7	16.70 ^{+0.40} / _{-0.20}	7.30 ± 0.15	4.70 ± 0.20	4.00 ± 0.20	12.50min	5.35 ± 0.15	2.22	36.78	16.58	610.22	3.40
EEL16.8	16.80 ± 0.30	12.50 ± 0.30	4.85 ± 0.20	4.00 ± 0.15	12.50min	10.30 ± 0.30	2.84	55.00	19.40	1067.00	5.72
EE17	16.90 ± 0.30	8.60 ± 0.20	7.35 ± 0.15	4.75 ± 0.12	11.55 ± 0.25	5.85 ± 0.15	1.01	38.35	37.80	1449.40	7.36
EEL17	17.00 ± 0.30	10.95 ^{+0.20} / _{-0.10}	3.60 ^{+0.10} / _{-0.20}	5.10 ^{+0.10} / _{-0.20}	12.20 ^{+0.25} / _{-0.15}	8.95 ^{+0.15} / _{-0.10}	3.00	49.82	16.63	828.51	4.40
EEL17A	17.00 ^{+0.30} / _{-0.20}	12.85 ± 0.15	3.55 ^{+0.10} / _{-0.20}	4.80 ± 0.15	12.20 ^{+0.30} / _{-0.10}	10.45 ^{+0.20} / _{-0.10}	3.33	56.74	17.04	966.85	4.78
EEL17B	17.20 ± 0.25	12.40 ± 0.20	4.80 ± 0.20	4.00 ± 0.20	12.60min	10.20 ± 0.20	2.77	56.24	20.28	1140.82	5.64
EE19	19.10 ± 0.30	8.15 ± 0.30	5.00 ± 0.20	4.55 ± 0.15	14.20min	5.70 ± 0.20	1.67	40.00	23.00	954.00	4.52
EE19A	19.00 ± 0.25	8.75 ± 0.20	4.15 ± 0.15	3.20 ± 0.15	14.60 ± 0.25	6.55 ± 0.20	2.70	43.06	15.91	685.13	3.64
EE19B	19.00 ± 0.40	8.30 ± 0.20	4.80 ± 0.20	4.60 ± 0.20	14.30min	5.80 ± 0.20	1.84	40.60	22.10	897.26	4.52
EE19C	19.00 ± 0.40	8.00 ± 0.15	4.80 ± 0.20	4.80 ± 0.20	14.30 ± 0.30	5.70 ± 0.15	1.76	39.63	22.55	893.73	4.86
EE19D	19.55 ± 0.55	8.05 ± 0.35	4.85 ± 0.25	4.85 ± 0.25	14.80min	5.75 ± 0.25	1.76	40.31	22.93	924.63	4.46
EE19.15	19.15 ± 0.40	7.90 ± 0.15	4.80 ± 0.20	4.65 ± 0.15	14.75 ± 0.30	5.60 ± 0.15	1.82	39.65	21.79	863.97	4.36
EE19/16	19.10 ± 0.30	8.10 ± 0.20	7.90 ± 0.20	4.55 ± 0.15	14.20min	5.70 ^{+0.10} / _{-0.20}	1.11	40.00	36.00	1507.00	7.10
EEL19	20.00 ± 0.30	13.70 ± 0.25	5.00 ^{+0.05} / _{-0.20}	4.55 ± 0.20	14.30min	11.15 ± 0.15	2.46	61.00	25.00	1553.00	7.40
EEL19.4	19.40 ^{+0.40} / _{-0.20}	14.25 ± 0.15	3.55 ^{+0.10} / _{-0.15}	6.00 ± 0.15	13.40 ^{+0.30} / _{-0.10}	11.25 ^{+0.20} / _{-0.10}	2.90	61.82	21.30	1316.87	6.30



■ ELECTRICAL CHARACTERISTICS

CORES	AL ± 25% (nH/N ²)							AL ± 30% (nH/N ²)				
	P4	P41	P46	P47	P48	P5	N42	A05	A07	A10(L)	A121(L)	A151(L)
EEL12.8-1	680											
EE12.9/10	2600						3250					
EE12.9A	610						720					
EE13	1250	1170	1420	1330		1070	1350	1650	1950	3300min		
EE13/3.55	1050											
EEL13									1300			
EEL13/3.1									1400			
EEL14	700											
EEL14A	500											
EEL14.15			1350									
EEL14.6A	700											
EE15										2000min		
EEL15.4A									1200			
EE16	1240	1200	1420	1320		1050		2090	2700	4500	5170	
EE16A	1550			1750				2490	2950	6600		
EE16D	1200											
EEL16	800	770		900		700		1590	1980	3300	3850	
EE16.5	2560											
EE16.5-1	2400							4200				
EE16.7	1050											
EEL16.8									1820			
EE17				3000								
EEL17	840											
EEL17A	770											
EEL17B								1700				
EE19	1300	1250	1520	1420	1300	1040		2240	3000	5100		
EE19A	900											
EE19B	1200							2120				
EE19C	1300											
EE19D	1360											
EE19.15								2000				
EE19/16	2100							3500	4700	9000		
EEL19	800	770	1200					1820	2280	3800		
EEL19.4	900											

Remark:

1. AL Value Testing Condition : 10kHz, 50mV, 100Ts. If testing condition is different from ACME's, please specify upon request & ordering.
2. Gapped core is available, please specify upon request & ordering. ACME's standard gapped core set is a combination of one gapped core and one ungapped core. If gapping on both pcs to make a set is needed, please specify upon request & ordering.
3. L : Mirror Finished Lapping. Please specify upon request & ordering by adding "L" at the end of Core Size if you need.

Type : EE/EEL Cores

Ordering Code:

Shape:

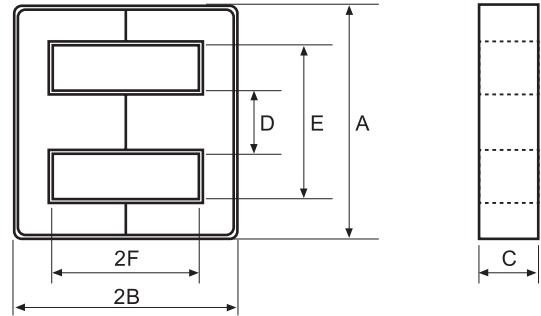
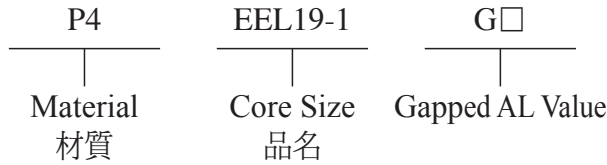

■ DIMENSIONS AND EFFECTIVE PARAMETERS

CORES	DIMENSIONS (mm)						EFFECTIVE PARAMETERS				
	A	B	C	D	E	F	Cl(mm ⁻¹)	Le(mm)	Ae(mm ²)	Ve(mm ³)	Wt(g/set)
EEL19-1	20.00 ± 0.25	13.70 ± 0.25	4.10 ± 0.10	4.55 ± 0.10	14.70 ± 0.20	11.15 ± 0.15	3.09	62.33	20.17	1257.19	6.44
EEL19A	20.00 ± 0.25	13.95 ± 0.25	5.00 ^{+0.05} _{-0.20}	4.55 ± 0.10	14.70 ± 0.20	11.40 ± 0.15	2.57	63.33	24.59	1557.28	7.50
EEL19D	20.00 ± 0.25	16.00 ± 0.25	4.90 ^{+0.15} _{-0.10}	4.55 ± 0.10	14.70 ± 0.20	13.40 ± 0.15	2.95	71.34	24.16	1723.57	8.82
EE19.8/10.6/5.8	19.80 ± 0.40	5.80 ± 0.20	10.60 ± 0.20	5.70 ± 0.20	14.40 ± 0.30	3.00 ± 0.20	0.50	29.45	59.02	1738.07	9.02
EE20A	20.00 ± 0.25	4.00 ± 0.10	9.95 ± 0.20	4.55 ± 0.15	14.70 ± 0.25	1.90 ± 0.10	0.56	24.77	44.48	1101.67	7.26
EEL20D	20.00 ± 0.25	14.30 ± 0.15	3.70 ± 0.15	6.00 ± 0.15	13.60 ± 0.25	11.30 ± 0.15	2.74	62.32	22.75	1417.78	7.16
EEL20H	20.00 ± 0.40	11.40 ± 0.20	5.65 ± 0.25	5.70 ± 0.20	14.10min	8.70 ± 0.20	1.64	52.09	31.76	1654.36	8.40
EE22	22.00 ± 0.40	9.20 ± 0.20	5.70 ± 0.30	5.75 ± 0.25	16.00 ± 0.40	5.40 ± 0.20	0.97	41.96	36.26	1610.00	7.80
EE22B	22.00 ± 0.40	9.20 ± 0.20	5.70 ± 0.30	5.75 ± 0.25	16.00 ± 0.40	5.40 ± 0.20	1.19	43.16	36.16	1560.77	8.20
EEL22	22.25 ± 0.30	15.26 ± 0.30	5.70 ± 0.30	5.70 ± 0.30	15.50min	11.20 ± 0.30	1.77	65.00	37.00	2405.00	11.74
EEL22A	22.40 ± 0.30	22.20 ± 0.30	4.70 ± 0.20	5.80 ± 0.20	16.00 ± 0.20	18.20 ± 0.20	3.15	93.21	29.58	2757.10	13.66
EEL22A/26.9	22.40 ± 0.30	26.90 ± 0.20	4.70 ± 0.20	5.80 ± 0.20	16.00 ± 0.20	22.90 ± 0.20	3.00	93.25	31.04	2894.48	16.46
EEL22B	22.00 ± 0.30	30.00 ± 0.25	4.70 ± 0.20	5.80 ± 0.20	15.90 ^{+0.25} _{-0.20}	26.50 ± 0.25	4.43	125.94	28.40	3576.94	8.68
EEL22C	22.40 ± 0.30	27.00 ± 0.20	4.70 ± 0.20	5.80 ± 0.20	15.80min	23.00 ± 0.20	3.86	112.47	29.12	3275.13	16.30
EE25/19	25.40 ± 0.50	9.70 ± 0.30	6.30 ± 0.20	6.35 ± 0.25	18.55min	6.65 ± 0.35	1.21	48.00	40.00	1962.00	9.36
EEL25	25.40 ± 0.40	15.90 ± 0.25	6.35 ± 0.25	6.35 ± 0.30	18.80min	12.70 ± 0.30	1.79	73.00	40.00	3005.00	14.50
EEL25A	25.10 ± 0.25	14.75 ± 0.20	4.75 ± 0.20	8.40 ± 0.20	17.10 ± 0.20	10.85 ± 0.15	1.68	64.61	38.45	2484.25	8.70
EEL25A/29.9	25.20 ± 0.25	14.95 ± 0.20	4.75 ± 0.20	8.40 ± 0.20	17.20 ± 0.20	11.05 ± 0.15	1.68	64.61	38.45	2484.25	12.20
EEL25C	25.20 ± 0.25	16.50 ± 0.20	4.00 ± 0.20	8.40 ± 0.20	17.20 ± 0.20	12.55 ^{+0.20} _{-0.15}	2.20	71.60	32.51	2327.60	11.48
EEL25E	25.20 ± 0.30	19.00 ± 0.20	4.00 ± 0.20	8.40 ± 0.20	17.00min	15.00 ± 0.25	2.50	81.48	32.62	2657.72	13.32
EEL27	26.50 ± 0.35	17.10 ± 0.15	3.75 ± 0.15	7.20 ± 0.15	16.90 ± 0.35	14.10 ± 0.15	2.68	75.30	28.12	2117.44	11.08
EEL28.4	28.40 ± 0.40	20.40 ± 0.20	11.50 ± 0.20	8.00 ± 0.20	20.00min	16.40 ± 0.20	0.96	90.30	93.70	8462.00	40.80
EEL30	30.20 ± 0.25	18.85 ± 0.20	4.00 ± 0.20	11.25 ± 0.20	19.20 ± 0.20	13.35 ^{+0.20} _{-0.15}	1.77	78.72	44.39	3494.40	17.70
EE30A	30.00 ^{+0.80} _{-0.60}	16.80 ± 0.20	7.05 ± 0.20	6.95 ± 0.20	19.90 ± 0.40	11.30 ± 0.20	1.17	70.80	60.59	4290.00	12.10
EE30.1	30.10 ± 0.70	15.00 ± 0.20	7.05 ± 0.25	6.95 ± 0.25	19.40 ± 0.40	10.00 ± 0.30	1.07	64.86	60.46	3921.66	21.16
EE35A	34.32 ± 0.61	14.12 ± 0.15	9.27 ± 0.25	9.32 ± 0.20	25.53min	9.78 ± 0.13	0.84	69.20	82.64	5719.22	14.39
EE36	36.15 ± 0.85	17.80 ± 0.20	11.25 ± 0.25	9.95 ± 0.25	24.50min	12.30 ± 0.30	0.71	81.72	115.51	9441.04	48.40
EEL38	37.30 ± 0.50	20.10 ± 0.25	4.60 ± 0.15	8.00 ± 0.15	28.40min	17.10 ± 0.25	2.89	98.33	34.08	3351.09	17.50
EEL40.4	40.40 ± 0.60	30.95 ± 0.25	8.00 ± 0.20	11.20 ± 0.25	29.20 ± 0.50	22.95 ± 0.25	1.36	129.29	94.96	12277.38	64.30
EEL41	41.00 ± 0.60	28.50 ± 0.25	3.50 ± 0.20	16.00 ± 0.25	25.00 ± 0.35	20.50 ± 0.25	2.07	116.13	56.00	6503.28	32.96
EE65	65.00 ^{+1.50} _{-1.20}	32.50 ± 0.30	26.90 ± 0.50	19.65 ± 0.35	45.10 ± 0.90	22.60 ± 0.40	0.28	146.93	532.11	78182.92	374.00



■ ELECTRICAL CHARACTERISTICS

CORES	AL ± 25% (nH/N ²)							AL ± 30% (nH/N ²)				
	P4	P41	P46	P47	P48	P5	N42	A05	A07	A10(L)	A121(L)	A151(L)
EEL19-1	850											
EEL19A	800								1900			
EEL19D	900											
EE19.8/10.6/5.8				4400								
EE20A	3536											
EEL20D										2550 ± 35%		
EEL20H										9500		
EE22	1900	1820	2315	2200								
EE22B	2000+25%-20%											
EEL22	1400								3090			
EEL22A	860											
EEL22A/26.9	780											
EEL22B	650											
EEL22C	740											
EE25/19	1800		2315			1500		3410	4400	8000	8500min	9500min
EEL25	1330							2580	3200	5600	5320min	
EEL25A	1550											
EEL25A/29.9	1500											
EEL25C	1200											
EEL25E	1600											
EEL27	1050											
EEL28.4	2400											
EEL30	1530											
EE30A	1900											
EE30.1	2300											
EE35A										8500min		
EE36		3700										
EEL38	920											
EEL40.4	1940											
EEL41	1350											
EE65	9500											

Remark:

1. AL Value Testing Condition : 10kHz, 50mV, 100Ts. If testing condition is different from ACME's, please specify upon request & ordering.
2. Gapped core is available, please specify upon request & ordering. ACME's standard gapped core set is a combination of one gapped core and one ungapped core. If gapping on both pcs to make a set is needed, please specify upon request & ordering.
3. L : Mirror Finished Lapping. Please specify upon request & ordering by adding "L" at the end of Core Size if you need.

Type : EF Cores

Ordering Code:

Shape:

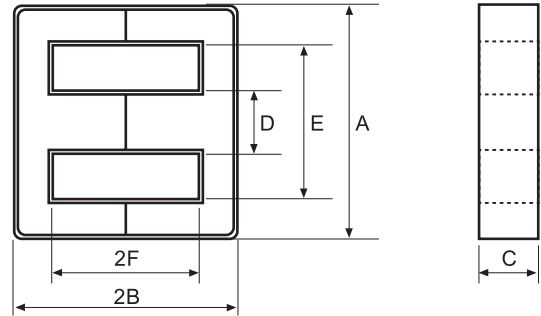
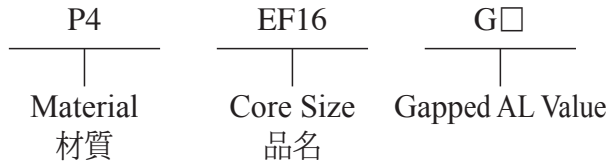

■ DIMENSIONS AND EFFECTIVE PARAMETERS

CORES	DIMENSIONS (mm)						EFFECTIVE PARAMETERS				
	A	B	C	D	E	F	C1(mm ⁻¹)	Le(mm)	Ae(mm ²)	Ve(mm ³)	Wt(g/set)
EF10	10.00 ± 0.30	5.00 ± 0.10	2.75 ± 0.15	2.88 ± 0.15	7.25 ± 0.25	3.63 ± 0.15	3.02	23.23	7.68	178.41	0.90
EF12.6	12.60 ± ^{0.50} _{0.40}	6.40 ± 0.10	3.60 ± 0.20	3.65 ± 0.15	8.80min	4.65 ± 0.15	2.39	29.60	12.40	367.00	1.88
EF12.6A	12.60 ± 0.40	6.90 ± 0.20	3.55 ± 0.15	3.50 ± 0.30	9.20 ± 0.30	4.90 ± 0.20	2.44	31.05	12.70	394.30	2.06
EF12.6B	12.60 ± 0.50	7.40 ± 0.15	3.55 ± 0.15	3.55 ± 0.15	9.20 ± 0.30	5.35 ± 0.15	2.57	32.86	12.81	420.80	2.14
EF12.6C	12.60 ± ^{0.50} _{0.40}	6.40 ± 0.10	3.60 ± 0.20	3.65 ± 0.15	8.80min	4.65 ± 0.15	2.39	29.60	12.40	367.04	1.88
EF12.6D	12.65 ± 0.45	6.40 ± 0.10	3.55 ± 0.15	3.55 ± 0.15	8.90min	4.65 ± 0.15	2.41	29.77	12.35	367.66	1.76
EF12.8	12.80 ± 0.30	10.00 ± 0.20	4.90 ± 0.20	3.70 ± 0.20	8.90min	8.30 ± 0.20	2.42	43.97	18.19	799.76	3.94
EF12.9	12.90 ± 0.25	6.50 ± 0.15	3.60 ± 0.15	3.60 ± 0.15	9.60 ± 0.20	4.65 ± 0.15	2.38	30.15	12.63	380.79	1.88
EF13.5	13.50 ± 0.30	6.75 ± 0.15	6.00 ± ^{0.15} _{0.20}	2.85 ± 0.15	10.50 ± 0.25	5.25 ± 0.20	1.88	33.28	17.67	588.06	2.86
EF16	16.10 ± 0.60	8.05 ± 0.15	4.50 ± 0.20	4.55 ± 0.15	11.30min	5.90 ± 0.20	1.87	37.60	20.10	754.00	3.70
EF16A	16.00 ± 0.30	7.95 ± 0.15	4.35 ± 0.15	4.35 ± 0.15	11.40min	5.80 ± 0.15	1.93	37.11	19.22	713.25	3.62
EF16C	16.00 ± ^{0.70} _{0.50}	8.05 ± 0.15	4.50 ± 0.20	4.55 ± 0.15	11.80min	5.90 ± 0.20	2.01	37.69	18.74	706.49	3.70
EF16.2	16.20 ± 0.40	9.50 ± 0.15	3.45 ± 0.15	4.60 ± 0.15	11.30min	7.25 ± 0.20	2.71	43.08	15.91	685.30	4.52
EF20	20.00 ± 0.40	9.90 ± 0.20	5.65 ± 0.25	5.70 ± 0.20	14.10min	7.20 ± 0.20	1.34	44.90	33.50	1500.00	7.30
EF20A	20.00 ± 0.40	10.60 ± 0.15	5.70 ± 0.20	5.70 ± 0.20	14.40 ± 0.30	7.60 ± 0.15	1.47	48.22	32.71	1577.54	7.98
EF24	24.00 ± 0.60	12.00 ± 0.35	5.75 ± 0.25	5.80 ± 0.20	16.30 ± 0.40	8.25 ± 0.25	1.38	53.82	38.88	2092.52	11.00
EF25	25.05 ± 0.75	12.55 ± 0.25	7.20 ± 0.30	7.25 ± 0.25	17.50min	8.95 ± 0.25	1.09	57.50	52.84	3038.30	14.68

■ ELECTRICAL CHARACTERISTICS

CORES	AL ± 25% (nH/N ²)					AL ± 30% (nH/N ²)		
	P4	P5	N42	A05	A07	A10(L)	A121(L)	A151(L)
EF10	670							
EF12.6	830	780	1200	1660	2100	3500	4000	4650
EF12.6A			1150					
EF12.6B	850							
EF12.6C							4000	
EF12.6D	830							
EF12.8			1035					
EF12.9						3900		
EF13.5	1020							
EF16	1100	1000	1700	1950	2540	4200min	4500min	
EF16A				1660				
EF16C	1100							
EF16.2	1000							
EF20	1570	1450		2920	3800	6350min		
EF20A	1600							
EF24	1800							
EF25	2000			3750	4880	8150min		

Remark:

1. AL Value Testing Condition : 10kHz, 50mV, 100Ts. If testing condition is different from ACME's, please specify upon request & ordering.
2. Gapped core is available, please specify upon request & ordering. ACME's standard gapped core set is a combination of one gapped core and one ungapped core. If gapping on both pcs to make a set is needed, please specify upon request & ordering.
3. L : Mirror Finished Lapping. Please specify upon request & ordering by adding "L" at the end of Core Size if you need.

Type : ET Cores

Ordering Code:

Shape:

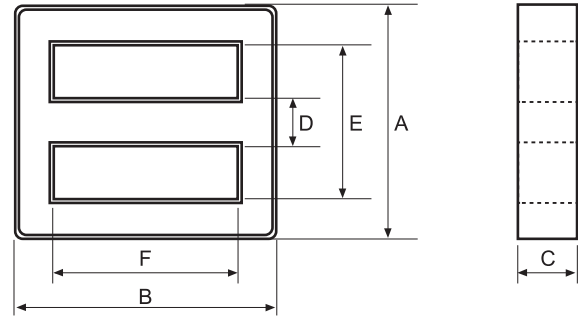
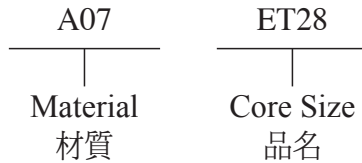

■ DIMENSIONS AND EFFECTIVE PARAMETERS

CORES	DIMENSIONS (mm)						EFFECTIVE PARAMETERS				
	A	B	C	D	E	F	C1(mm ⁻¹)	Le(mm)	Ae(mm ²)	Ve(mm ³)	Wt(g/set)
ET20	20.10 ± 0.40	20.10 ± 0.40	4.40 ± 0.20	4.00 ± 0.20	15.70min	15.70min	2.96	52.10	17.60	917.00	3.88
ET20A	20.30 ± 0.50	20.30 ± 0.50	4.40 ± 0.20	4.00 ± 0.20	16.10min	15.80min	2.72	50.36	18.51	932.00	4.41
ET24	24.20 ± 0.50	24.20 ± 0.50	4.00 ± 0.30	4.00 ± 0.20	19.00min	19.00min	3.31	60.00	18.00	1098.00	5.15
ET28	28.40 ± 0.50	28.40 ± 0.50	5.00 ± 0.30	5.00 ± 0.30	22.20min	22.20min	2.54	70.00	27.00	1972.00	9.71
ET29	28.70 ± 0.50	28.70 ± 0.50	5.00 ± 0.30	5.00 ± 0.30	22.20min	22.20min	2.55	71.41	28.02	2000.71	10.25

■ ELECTRICAL CHARACTERISTICS

CORES	AL ± 25% (nH/N ²)	AL ± 30% (nH/N ²)		
	A07	A10	A121	A151
ET20	3100	4400	4850	6370
ET20A		4800		
ET24	2800	3800	4300	5600
ET28	3100 - 4500	4000min	5800	7200
ET29				6000 +40% -30%

Remark:

AL Value Testing Condition : 10kHz, 50mV, 1Ts. If testing condition is different from ACME's, please specify upon request & ordering.

Type : UU Cores

Ordering Code:

A10

UU10.5

L

Material
材質

Core Size
品名

Lapping
鏡面拋光

Shape:

Type:1

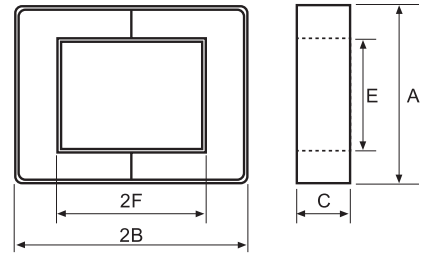

Type:2

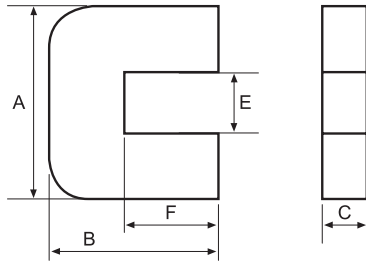

Type:3

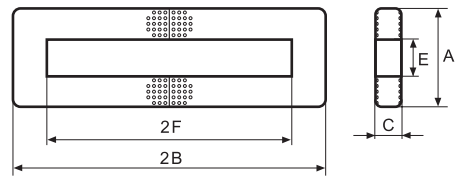

Type:4

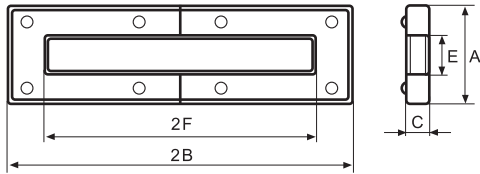

Type:5

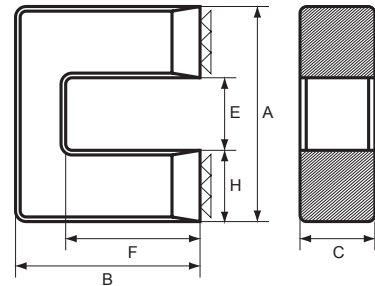

■ DIMENSIONS AND EFFECTIVE PARAMETERS

CORES	DIMENSIONS (mm)						Type
	A	B	C	E	F	H	
UU5.2	5.20 ^{+0.10} / _{-0.20}	7.40 ± 0.15	2.85 ± 0.10	2.25 ± 0.15	5.85 ± 0.15		1
UU8.5	8.50 ± 0.20	4.70 ± 0.15	3.60 ± 0.15	3.50 ± 0.15	2.40 ± 0.15		1
UU9.5	9.50 ± 0.20	6.80 ± 0.20	3.90 ± 0.10	3.50 ± 0.20	3.50 ± 0.20		1
UU9.8	9.80 ± 0.20	7.20 ± 0.10	2.70 ± 0.20	4.20min	4.20 ± 0.20		1
UU9.8B	9.80 ± 0.30	9.00 ± 0.20	3.40 ± 0.20	3.65min	6.00 ± 0.20		1
UU10B	10.00 ^{+0.30} / _{-0.20}	5.00 ^{+0.00} / _{-0.20}	6.00 ± 0.20	4.50min	2.40 ± 0.10		1
UU10.5	10.50 ± 0.25	8.00 ± 0.30	5.00 ± 0.15	5.35min	5.30 ± 0.30		1
UU11	11.00 ^{+0.00} / _{0.60}	8.10 ^{+0.10} / _{0.20}	5.45 ± 0.20	5.50 ± 0.20	5.80 ^{+0.20} / _{0.10}		1
UU11.2A	11.15 ± 0.25	14.05 ± 0.10	7.40 ± 0.20	4.55 ± 0.25	10.80 ± 0.15		1
UU12	12.00 ± 0.30	7.90 ± 0.10	4.45 ± 0.15	7.20min	5.65 ± 0.10		1
UU13.5	13.50 ± 0.25	10.50 ± 0.10	3.55 ± 0.20	4.15 ± 0.15	7.90 ± 0.10		2
UU14	14.00 ± 0.30	30.60 ± 0.20	3.40 ± 0.25	5.00 ± 0.30	23.60 ± 0.20		4
UU15	15.20 ± 0.70	11.40 ± 0.50	6.45 ± 0.25	5.20min	6.25 ± 0.35		1
UU15.1	15.10 ± 0.30	30.65 ± 0.20	3.20 ± 0.20	6.10 ± 0.25	24.65 ± 0.20		4
UU15.1B	15.10 ± 0.30	32.00 ± 0.20	3.20 ± 0.25	6.10 ± 0.30	26.00 ± 0.20		1
UU16	16.00 ± 0.30	10.00 ± 0.20	6.00 ± 0.15	6.70min	6.00 ± 0.15		1
UU16.5	16.50 ± 0.30	29.90 ± 0.20	3.70 ± 0.15	5.50 ± 0.25	23.90 ± 0.20		3
UU16.5A	16.50 ± 0.30	22.65 ± 0.20	3.70 ± 0.20	5.50 ± 0.25	16.65 ± 0.20		3
UU16.6	16.60 ± 0.30	29.30 ± 0.30	4.00 ± 0.20	5.60 ± 0.20	24.30 ± 0.20		4
UU17.8	17.80 ± 0.30	33.50 ± 0.20	3.30 ± 0.20	5.80 ± 0.25	29.50 ± 0.20		4
UU17.8B	17.80 ± 0.30	36.20 ± 0.20	3.30 ± 0.20	5.80 ± 0.25	30.20 ± 0.20		1
UU18.2	18.20 ± 0.40	31.20 ± 0.20	3.50 ± 0.20	6.20 ± 0.25	25.20 ± 0.20		4
UU18.5	18.50 ± 0.30	36.90 ± 0.20	5.70 ± 0.18	6.50 ± 0.25	30.90 ± 0.20		1
UU19	19.05 ± 0.35	17.00 ± 0.15	2.00 ± 0.10	4.35 ± 0.10	11.60 ± 0.15		2
UU19.4	19.40 ± 0.30	11.00 ± 0.20	4.50 ± 0.20	6.60 ± 0.30	8.00 ± 0.20	6.40 ± 0.20	5
UU19.6	19.60 ± 0.30	18.30 ± 0.20	5.00 ± 0.15	10.60 ± 0.30	13.30 ± 0.20		1
UU19.6A	19.60 ± 0.40	37.60 ± 0.20	3.80 ± 0.20	5.00 ± 0.25	29.80 ± 0.20		4
UU19.6B	19.60 ± 0.30	38.00 ± 0.20	3.80 ± 0.20	5.00 ± 0.25	30.20 ± 0.20		1
UU22	22.00 ± 0.30	15.00 ± 0.25	10.00 ± 0.30	12.00min	10.00 ± 0.25		1
UU24	24.00 ± 0.35	21.60 ± 0.20	3.60 ± 0.20	5.00 ± 0.20	13.60 ± 0.20		4
UU32.5	32.50 ± 0.50	27.75 ± 0.25	12.50 ± 0.20	13.50 ± 0.20	18.20 ± 0.20		1



■ EFFECTIVE PARAMETERS

CORES	EFFECTIVE PARAMETERS				
	C _i (mm ⁻¹)	Le(mm)	Ae(mm ²)	Ve(mm ³)	Wt(g/set)
UU5.2	4.69	32.64	4.25	138.60	0.70
UU8.5	2.78	24.11	8.66	208.77	1.12
UU9.5	2.54	30.85	12.11	373.87	1.96
UU9.8	4.30	34.00	8.00	271.00	1.26
UU9.8B	4.05	41.09	10.14	416.62	2.22
UU10B	1.68	26.99	16.04	432.97	2.24
UU10.5	3.14	40.00	13.00	518.00	2.52
UU11	3.00	41.88	13.95	584.26	2.92
UU11.2A	2.57	62.58	24.33	1523.00	7.76
UU12	4.39	44.54	10.14	451.63	2.24
UU13.5	6.78	89.15	13.14	636.83	3.72
UU14	7.51	120.60	16.05	1935.54	10.14
UU15	1.58	51.00	33.00	1673.00	8.16
UU15.1	8.46	126.35	14.93	1886.41	9.60
UU15.1B	8.84	131.74	14.90	1963.54	10.00
UU16	1.93	52.00	27.00	1381.00	6.56
UU16.5	6.04	124.57	20.62	2568.33	13.00
UU16.5A	4.62	95.58	20.70	1978.59	10.22
UU16.6	5.76	124.78	21.65	2701.31	13.50
UU17.8	7.79	142.71	18.32	2614.45	14.60
UU17.8B	7.64	151.25	19.80	2994.77	14.86
UU18.2	6.29	132.05	21.00	2773.05	13.84
UU18.5	4.55	155.45	34.20	5316.39	26.36
UU19	5.47	70.60	12.90	910.74	7.30
UU19.4	2.79	53.93	19.35	1043.55	6.98
UU19.6	3.84	89.15	23.21	2069.17	10.15
UU19.6A	5.46	152.87	27.99	4278.83	22.00
UU19.6B	5.52	154.47	27.99	4323.62	21.66
UU22	1.63	80.06	49.09	3929.91	19.40
UU24	2.81	91.56	32.58	2982.94	15.20
UU32.5	1.11	129.31	116.80	15103.41	82.26

■ EFFECTIVE PARAMETERS

CORES	AL ± 25% (nH/N ²)							AL ± 30% (nH/N ²)			
	P4	P41	P47	N42	P5	A05	A07	A10	A10(L)	A121(L)	A151(L)
UU5.2	480										
UU8.5				960							
UU9.5						1300					
UU9.8	500				450	930	1300		1600	1309min	1509min
UU9.8B								1400			
UU10B						1900					
UU10.5	720				650	1220	1650	1800	2800	2800min	4010
UU11	720					1300					
UU11.2A	930										
UU12			630(P46)								
UU13.5	680										
UU14	430										
UU15	1350		1500		1300	2680	3320		6000		
UU15.1	340										
UU15.1B	320										
UU16	1140				1050	2140	2720		5710	5100min	5700min
UU16.5	470										
UU16.5A			830(P46)								
UU16.6	490										
UU17.8	430										
UU17.8B	440										
UU18.2	500										
UU18.5	500										
UU19	500										
UU19.4									4200		
UU19.6	695										
UU19.6A	530										
UU19.6B	570										
UU22				2000							
UU24			1300								
UU32.5		2490									

Remark:

1. AL Value Testing Condition : 10kHz, 50mV, 100Ts. If testing condition is different from ACME's, please specify upon request & ordering.
2. L : Mirror Finished Lapping. Please specify upon request & ordering by adding "L" at the end of Core Size if you need.

Type : RF Cores

Ordering Code:

A05	RF10x5.1x20
Material	Core Size
材質	品名

Shape:

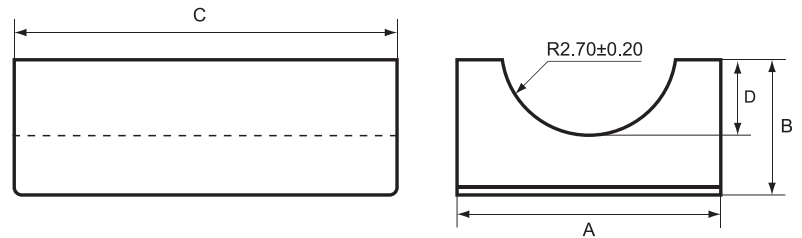

■ DIMENSIONS

CORES	DIMENSIONS (mm)			
	A	B	C	D
RF10x5.1x20	10.00 ± 0.30	5.10 ± 0.10	20.00 ± 0.50	2.70 ± 0.20

■ EFFECTIVE PARAMETERS

CORES	EFFECTIVE PARAMETERS				
	C _l (mm ⁻¹)	Le(mm)	Ae(mm ²)	Ve(mm ³)	Wt(g/set)
RF10x5.1x20	0.51	22.72	44.57	1013	3.67

■ ELECTRICAL CHARACTERISTICS

CORES	AL ± 25% (nH/N ²)				
	P4	P41	P46	A05	A07
RF10x5.1x20				3600	

Remark:

AL Value Testing Condition : 10kHz, 50mV, 100Ts. If testing condition is different from ACME's, please specify upon request & ordering.

Type : UI Cores

Ordering Code:

A10	UI11.4
Material 材質	Core Size 品名

Shape:

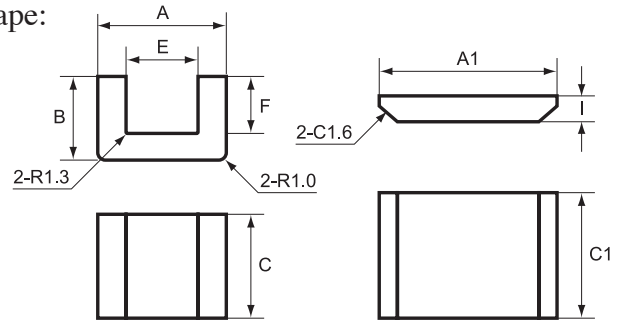

■ DIMENSIONS

CORES	DIMENSIONS (mm)								
	A	B	C	D	E	F	A1	C1	I
UI11.4	11.40 ± 0.30	8.10 ± 0.20	10.20 ± 0.20		6.40 ± 0.30	5.60 ± 0.20	15.90 ± 0.30	12.10 ± 0.30	2.50 ± 0.10

■ EFFECTIVE PARAMETERS

CORES	EFFECTIVE PARAMETERS				
	C ₁ (mm ⁻¹)	Le(mm)	Ae(mm ²)	Ve(mm ³)	Wt(g/set)
UI11.4	1.25	31.85	25.50	812.27	4.90

■ ELECTRICAL CHARACTERISTICS

CORES	AL ± 25% (nH/N ²)			AL ± 30% (nH/N ²)
	P4	P41	P46	A10
UI11.4				2800

Remark:

AL Value Testing Condition : 10kHz, 50mV, 100Ts. If testing condition is different from ACME's, please specify upon request & ordering.

Type : UT Cores

Ordering Code:

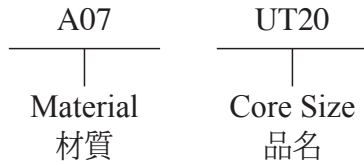

Shape:

Type:1

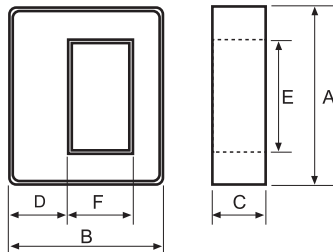

Type:2

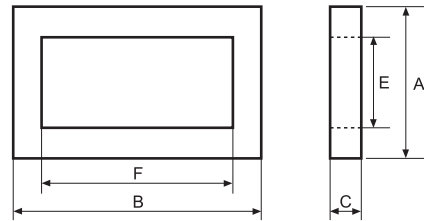

■ DIMENSIONS

CORES	DIMENSIONS (mm)						EFFECTIVE PARAMETERS					Type
	A	B	C	D	E	F	C ₁ (mm ⁻¹)	Le(mm)	Ae(mm ²)	Ve(mm ³)	Wt(g/set)	
UT8	8.00 ± 0.10	16.00 ± 0.25	2.00 ± 0.10	—	4.00 ± 0.10	12.00min	3.79	38.28	4.00	153.12	0.76	2
UT20	20.60 ± 0.30	14.10 ± 0.25	4.60 ± 0.20	4.10 ± 0.20	15.70min	7.35min	4.11	53.00	13.00	688.00	3.76	1
UT25	25.60 ± 0.40	17.60 ± 0.30	5.20 ± 0.25	5.20 ± 0.15	19.30min	8.70min	3.77	68.00	18.00	1203.00	5.85	1
UT30	30.00 ± 0.40	19.80 ± 0.30	6.40 ± 0.25	6.40 ± 0.15	22.40min	8.90min	2.85	77.00	27.00	2068.00	11.05	1

■ ELECTRICAL CHARACTERISTICS

CORES	AL ± 25% (nH/N ²)	AL ± 30% (nH/N ²)		
	A07	A10	A121	A151
UT8		1300		
UT20	2140	3000	3700	4625
UT25	2350 +40% -20%	3350		
UT30	3150 +40% -20%	4500		

Remark:

AL Value Testing Condition : 10kHz, 50mV, 1Ts. If testing condition is different from ACME's, please specify upon request & ordering.

Type : RID Cores

Ordering Code:

Shape:

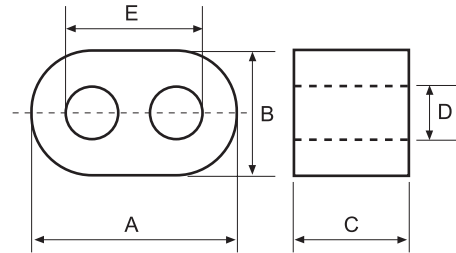
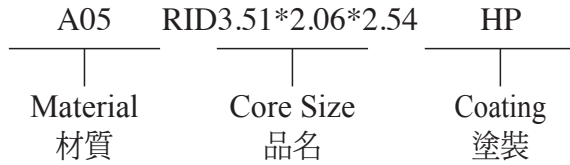

C : Epoxy Coating of Halogen-Free UC : Epoxy Coating of UL & Halogen
 HP : Parylene Coating of Halogen-Free P : Parylene Coating of Halogen

■ DIMENSIONS

CORES	DIMENSIONS (mm)				
	A	B	C	D	E
RID3.51x2.06x2.54	3.51 ± 0.15	2.06 ± 0.15	2.54 ± 0.15	0.86 ± 0.10	2.34 ± 0.10

Type : T Cores

Ordering Code:

Shape:

A10	T2.5*1.5*1.3	HP	G□
Material 材質	Core Size 品名	Coating 塗裝	Gapped AL Value

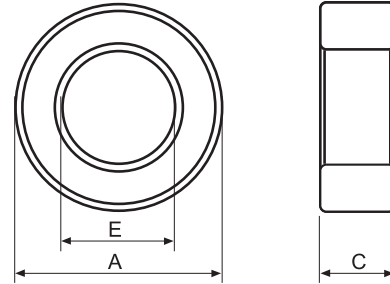

C : Epoxy Coating of Halogen-Free UC : Epoxy Coating of UL & Halogen
 HP : Parylene Coating of Halogen-Free P : Parylene Coating of Halogen

■ DIMENSIONS AND EFFECTIVE PARAMETERS

CORES	DIMENSIONS (mm)			EFFECTIVE PARAMETERS				
	PARYLENE COATING DIMENSIONS (mm)			C _i (mm ²)	Le(mm)	Ae(mm ²)	Ve(mm ³)	Wt(g/set)
	A	E	C					
T2.5x1.5x1.3	2.50 ± 0.15	1.50 ± 0.15	1.30 ± 0.15	9.67	6.28	0.65	4.08	0.020
	2.50 ± 0.15	1.50 ± 0.15	1.30 ± 0.15					
T2.54x1.27x1.27	2.54 ± 0.15	1.27 ± 0.15	1.27 ± 0.15	7.42	5.98	0.81	4.83	0.022
	2.54 ± 0.15	1.27 ± 0.15	1.27 ± 0.15					
T2.57x1.5x1.3	2.57 ± 0.15	1.50 ± 0.15	1.30 ± 0.15	8.88	6.39	0.72	4.60	0.021
	2.57 ± 0.15	1.50 ± 0.15	1.30 ± 0.15					
T2.9x1.5x1.7	2.90 ± 0.15	1.50 ± 0.15	1.70 ± 0.15	5.81	6.91	1.19	8.22	0.039
	2.90 ± 0.15	1.50 ± 0.15	1.70 ± 0.15					
T2.93x1.63x2.42	2.93 ± 0.15	1.63 ± 0.15	2.42 ± 0.15	4.55	7.16	1.57	11.27	0.049
	2.93 ± 0.15	1.63 ± 0.15	2.42 ± 0.15					
T3.05x1.27x2	3.05 ± 0.15	1.27 ± 0.15	2.00 ± 0.15	3.81	6.79	1.78	12.08	0.055
	3.05 ± 0.15	1.27 ± 0.15	2.00 ± 0.15					
T3.05x1.5x2.06	3.05 ± 0.15	1.50 ± 0.15	2.06 ± 0.15	4.48	7.15	1.60	11.41	0.053
	3.05 ± 0.15	1.50 ± 0.15	2.06 ± 0.15					
T3.05x1.68x2.06	3.05 ± 0.15	1.68 ± 0.15	2.06 ± 0.15	5.27	7.43	1.41	10.48	0.048
	3.05 ± 0.15	1.68 ± 0.15	2.06 ± 0.15					
T3.05x1.68x2.4	3.05 ± 0.15	1.68 ± 0.15	2.40 ± 0.15	4.51	7.42	1.64	12.20	0.058
	3.05 ± 0.15	1.68 ± 0.15	2.40 ± 0.15					
T3.05x1.78x2.07	3.05 ± 0.15	1.78 ± 0.15	2.07 ± 0.15	5.77	7.59	1.31	9.97	0.045
	3.05 ± 0.15	1.78 ± 0.15	2.07 ± 0.15					
T3.25x1.4x0.78	3.25 ± 0.15	1.40 ± 0.15	0.78 ± 0.15	10.12	7.30	0.72	5.27	0.025
	3.25 ± 0.15	1.40 ± 0.15	0.78 ± 0.15					
T3.3x2x2.2	3.30 ± 0.15	2.00 ± 0.15	2.20 ± 0.15	0.17	1.43	8.33	11.91	0.056
	3.30 ± 0.15	2.00 ± 0.15	2.20 ± 0.15					
T3.43x1.27x1.27	3.43 ± 0.15	1.27 ± 0.15	1.27 ± 0.15	5.39	7.38	1.37	10.11	0.048
	3.43 ± 0.15	1.27 ± 0.15	1.27 ± 0.15					
T3.43x1.78x1.78	3.43 ± 0.15	1.78 ± 0.15	1.78 ± 0.15	5.57	8.18	1.47	12.02	0.054
	3.43 ± 0.15	1.78 ± 0.15	1.78 ± 0.15					
T3.45x1.75x1.3	3.45 ± 0.15	1.75 ± 0.15	1.30 ± 0.15	7.53	8.33	1.11	9.20	0.042
	3.45 ± 0.15	1.75 ± 0.15	1.30 ± 0.15					
T3.45x1.75x2.2	3.45 ± 0.15	1.75 ± 0.15	2.20 ± 0.15	4.45	8.33	1.87	15.57	0.075
	3.45 ± 0.15	1.75 ± 0.15	2.20 ± 0.15					
T3.45x1.78x2.2	3.45 ± 0.15	1.78 ± 0.15	2.20 ± 0.15	4.47	8.22	1.84	15.09	0.072
	3.45 ± 0.15	1.78 ± 0.15	2.20 ± 0.15					
T3.5x1.5x1.78	3.50 ± 0.15	1.50 ± 0.15	1.78 ± 0.15	4.41	7.85	1.78	13.98	0.068
	3.50 ± 0.15	1.50 ± 0.15	1.78 ± 0.15					
T3.5x1.8x1.8	3.50 ± 0.15	1.80 ± 0.15	1.80 ± 0.15	5.44	8.33	1.53	12.74	0.050
	3.50 ± 0.15	1.80 ± 0.15	1.80 ± 0.15					



MANUFACTURING CAPABILITY

Gapped Toroid Sizes(OD)	2.50mm - 12.00mm
Height	0.70mm - 8.00mm
Gap Sizes :	0.03mm - 0.80mm
AL Tolerance	AL ± 10%

APPLICATIONS

- Power**
 - DC-DC Converters
 - Compact Power Transformer
 - Small, Low Profile Power Inductors
- Telecom**
 - xDSL pass-band Filiterers
 - Spilters
 - EMI Inductors
 - Filiter Inductors with Tight Tolerance

■ ELECTRICAL CHARACTERISTICS

CORES	AL ± 25% (nH/N ²)							AL ± 30% (nH/N ²)			
	P4	P47	P5	N42	A043	A05	A07	A10	A102	A121	A151
T2.5x1.5x1.3	330		260			650		1300	1300	1560	1950
T2.54x1.27x1.27	440			640	760	880	1230	1760	1760	1930	2540
T2.57x1.5x1.3								1370	1370		
T2.9x1.5x1.7					970						
T2.93x1.63x2.42	650		550		1240	1350	1900	2700	2700	3300	
T3.05x1.27x2	800		650			1600	2300	3250	3250	3900	
T3.05x1.5x2.06	700		560			1400	1965	2810	2810	3370	4210
T3.05x1.68x2.06	600				1070	1190					3580
T3.05x1.68x2.4	695		555	1060	1250	1390	1950	2780	2780	3340	4170
T3.05x1.78x2.07	500		400		980	1050	1500	2150	2150	2600	
T3.25x1.4x0.78					560						
T3.3x2x2.2					970	1080					
T3.43x1.27x1.27					1050						
T3.43x1.78x1.78	560			860	1015		1580				
T3.45x1.75x1.3	425		340		775	850	1190	1700	1700	2040	2550
T3.45x1.75x2.2	720				1295	1635	2015	2880	2880		
T3.45x1.78x2.2					1265						
T3.5x1.5x1.78						1450					
T3.5x1.8x1.8	580			880		1150	1600	2300	2300	2700	3465

Remark:

1. AL Value Testing Condition : 10kHz, 50mV, 1Ts. If testing condition is different from ACME's, please specify upon request & ordering.
2. Coating Material
 - (1) Toroid Size T8 and Below:clear parylene coating, breakdown voltage:1000Vdc, coating thickness : 0.05mm max.
 - (2) Toroid Size T9 and Above:green epoxy coating, breakdown voltage:1500Vdc, coating thickness : 0.6mm max.

Type : T Cores

Ordering Code:

Shape:

A10	T3.68*1.65*2.54	HP	G□
Material 材質	Core Size 品名	Coating 塗裝	Gapped AL Value

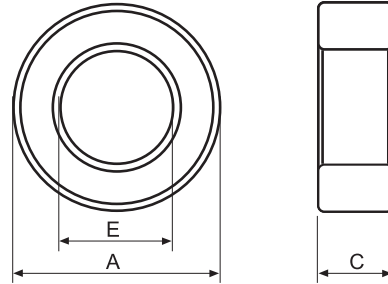

C : Epoxy Coating of Halogen-Free UC : Epoxy Coating of UL & Halogen
 HP : Parylene Coating of Halogen-Free P : Parylene Coating of Halogen

■ DIMENSIONS AND EFFECTIVE PARAMETERS

CORES	DIMENSIONS (mm)			EFFECTIVE PARAMETERS				
	PARYLENE COATING DIMENSIONS (mm)			C _i (mm ⁻¹)	Le(mm)	Ae(mm ²)	Ve(mm ³)	Wt(g/set)
	A	E	C					
T3.68x1.65x2.54	3.68 ± 0.15	1.65 ± 0.15	2.54 ± 0.15	3.24	8.37	2.58	21.59	0.101
	3.68 ± 0.15	1.65 ± 0.15	2.54 ± 0.15					
T3.94x1.68x0.76	3.94 ± 0.15	1.68 ± 0.15	0.76 ± 0.15	10.28	8.83	0.86	7.58	0.033
	3.94 ± 0.15	1.68 ± 0.15	0.76 ± 0.15					
T3.94x2.24x1.27	3.94 ± 0.15	2.24 ± 0.15	1.27 ± 0.15	9.20	9.75	1.06	10.34	0.050
	3.94 ± 0.15	2.24 ± 0.15	1.27 ± 0.15					
T3.94x2.24x2.54	3.94 ± 0.15	2.24 ± 0.15	2.54 ± 0.15	4.50	9.71	2.16	20.96	0.090
	3.94 ± 0.15	2.24 ± 0.15	2.54 ± 0.15					
T3.95x2.5x2.5	3.95 ± 0.20	2.50 ± 0.20	2.50 ± 0.20	5.49	9.79	1.78	17.43	0.080
	3.95 ± 0.20	2.50 ± 0.20	2.50 ± 0.20					
T4x2x1	4.00 ± 0.30	2.00 ± 0.30	1.00 ± 0.20	9.42	9.42	1.00	9.42	0.050
	4.00 ± 0.30	2.00 ± 0.30	1.00 ± 0.20					
T4x2x2	4.00 ± 0.20	2.00 ± 0.20	2.00 ± 0.20	4.71	9.42	2.00	18.85	0.099
	4.00 ± 0.20	2.00 ± 0.20	2.00 ± 0.20					
T4x2x2.54	4.00 ± 0.20	2.00 ± 0.20	2.54 ± 0.20	3.71	9.42	2.54	23.94	0.130
	4.00 ± 0.20	2.00 ± 0.20	2.54 ± 0.20					
T4x2.2x1.6	4.00 ± 0.20	2.20 ± 0.20	1.60 ± 0.20	6.76	9.74	1.44	14.02	0.069
	4.00 ± 0.20	2.20 ± 0.20	1.60 ± 0.20					
T4x2.4x1.6	4.00 ± 0.20	2.40 ± 0.15	1.60 ± 0.15	7.85	10.04	1.28	12.86	0.063
	4.00 ± 0.20	2.40 ± 0.15	1.60 ± 0.15					
T4.3x1.27x0.76	4.30 ± 0.15	1.27 ± 0.15	0.76 ± 0.15	0.13	8.75	1.15	10.06	0.048
	4.30 ± 0.15	1.27 ± 0.15	0.76 ± 0.15					
T4.3x2.1x1.75	4.30 ± 0.20	2.10 ± 0.20	1.75 ± 0.20	5.22	10.05	1.93	19.35	0.090
	4.30 ± 0.20	2.10 ± 0.20	1.75 ± 0.20					
T4.3x2.8x2.5	4.30 ± 0.20	2.80 ± 0.30	2.50 ± 0.20	5.93	11.15	1.88	20.96	0.098
	4.30 ± 0.20	2.80 ± 0.30	2.50 ± 0.20					
T4.4x1.78x0.76	4.40 ± 0.20	1.78 ± 0.20	0.76 ± 0.20	9.75	9.71	1.00	9.66	0.045
	4.40 ± 0.20	1.78 ± 0.20	0.76 ± 0.20					
T4.5x2.7x1.3	4.50 ± 0.20	2.70 ± 0.20	1.30 ± 0.20	9.66	11.30	1.17	13.22	0.065
	4.50 ± 0.20	2.70 ± 0.20	1.30 ± 0.20					
T4.83x2.29x1.27	4.83 ± 0.12	2.29 ± 0.15	1.27 ± 0.15	6.93	11.18	1.61	18.04	0.087
	4.83 ± 0.12	2.29 ± 0.15	1.27 ± 0.15					
T4.83x2.29x2.54	4.83 ± 0.12	2.29 ± 0.15	2.54 ± 0.12	3.47	11.18	3.23	36.08	0.190
	4.83 ± 0.12	2.29 ± 0.15	2.54 ± 0.12					
T4.95x1.55x2.84	4.95 ± 0.20	1.55 ± 0.20	2.84 ± 0.20	2.12	10.21	4.82	49.21	0.230
	4.95 ± 0.20	1.55 ± 0.20	2.84 ± 0.20					
T5x3x3.1	5.00 ± 0.30	3.00 ± 0.30	3.10 ± 0.30	3.97	12.04	3.03	36.51	0.090
	5.00 ± 0.30	3.00 ± 0.30	3.10 ± 0.30					
T5.05x1.78x0.85	5.05 ± 0.20	1.78 ± 0.20	0.85 ± 0.20	7.79	10.76	1.38	14.86	0.069
	5.05 ± 0.20	1.78 ± 0.20	0.85 ± 0.20					
T5.05x2.42x1	5.05 ± 0.20	2.42 ± 0.18	1.00 ± 0.18	8.92	11.73	1.32	15.43	0.072
	5.05 ± 0.20	2.42 ± 0.18	1.00 ± 0.18					



MANUFACTURING CAPABILITY

Gapped Toroid Sizes(OD)	2.50mm - 12.00mm
Height	0.70mm - 8.00mm
Gap Sizes :	0.03mm - 0.80mm
AL Tolerance	AL ± 10%

APPLICATIONS

- Power**
 - DC-DC Converters
 - Compact Power Transformer
 - Small, Low Profile Power Inductors
- Telecom**
 - xDSL pass-band Filtrers
 - Spilters
 - EMI Inductors
 - Filiter Inductors with Tight Tolerance

■ ELECTRICAL CHARACTERISTICS

CORES	AL ± 25% (nH/N ²)						AL ± 30% (nH/N ²)				
	P4	P47	P5	N42	A043	A05	A07	A10	A102	A121	A151
T3.68x1.65x2.54					1740						
T3.94x1.68x0.76	300					600	830	1200	1200		
T3.94x2.24x1.27	350					690	980	1400	1400	1670	2100
T3.94x2.24x2.54	740		560		1260	1475	2065	2950	2950	3350	4195
T3.95x2.5x2.5											3120
T4x2x1	330				600	720	920	1300	1300		
T4x2x2	640		530	1010	1200	1400	2000	2500	2500	3200	4000
T4x2x2.54	880			1290		1760	2460	3520	3520	3050min	5080
T4x2.2x1.6	460	550	380			930		1850	1850		2790
T4x2.4x1.6	400		320	610	720	800	1120	1600	1600	1920	2400
T4.3x1.27x0.76						825					
T4.3x2.1x1.75	600	720	450	915		1200	1650	2400	2400	2850	
T4.3x2.8x2.5	530		420				1480				3170
T4.4x1.78x0.76	300		250			600	900	1250	1250	1500	
T4.5x2.7x1.3					550			1300	1300		
T4.83x2.29x1.27	470		360	690		940	1320	1890	1890		
T4.83x2.29x2.54	950		720	1380		1900	2660	3800	3800	4350	
T4.95x1.55x2.84							4100	5900	5900		
T5x3x3.1					1390						
T5.05x1.78x0.85	400		300			800	1100	1600	1600	1900	2440
T5.05x2.42x1	350		280					1410	1410		

Remark:

1. AL Value Testing Condition : 10kHz, 50mV, 1Ts. If testing condition is different from ACME's, please specify upon request & ordering.
2. Coating Material
 - (1) Toroid Size T8 and Below:clear parylene coating, breakdown voltage:1000Vdc, coating thickness : 0.05mm max.
 - (2) Toroid Size T9 and Above:green epoxy coating, breakdown voltage:1500Vdc, coating thickness : 0.6mm max.

Type : T Cores

Ordering Code:

Shape:

P4	T5.84*3.05*1.52	HP	G□
Material 材質	Core Size 品名	Coating 塗裝	Gapped AL Value

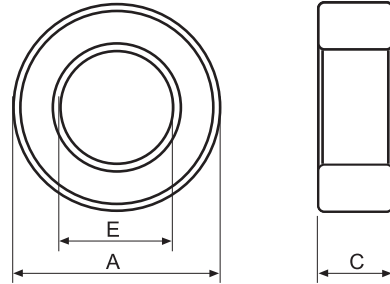

C : Epoxy Coating of Halogen-Free UC : Epoxy Coating of UL & Halogen
 HP : Parylene Coating of Halogen-Free P : Parylene Coating of Halogen

■ DIMENSIONS AND EFFECTIVE PARAMETERS

CORES	DIMENSIONS (mm)			EFFECTIVE PARAMETERS				
	PARYLENE COATING DIMENSIONS (mm)			C ₁ (mm ⁻¹)	L _e (mm)	A _e (mm ²)	V _e (mm ³)	Wt(g/set)
	A	E	C					
T5.33x3.12x1.98	5.33 ± 0.20	3.12 ± 0.20	1.98 ± 0.20	5.93	12.66	2.14	27.05	0.12
	5.33 ± 0.20	3.12 ± 0.20	1.98 ± 0.20					
T5.4x2.6x2	5.40 ± 0.20	2.60 ± 0.20	2.00 ± 0.20	4.30	11.51	2.68	30.84	0.17
	5.40 ± 0.20	2.60 ± 0.20	2.00 ± 0.20					
T5.84x3.05x1.52	5.84 ± 0.15	3.05 ± 0.15	1.52 ± 0.15	6.59	13.96	2.12	29.61	0.14
	5.84 ± 0.15	3.05 ± 0.15	1.52 ± 0.15					
T5.84x3.05x3.05	5.84 ± 0.15	3.05 ± 0.15	3.05 ± 0.15	3.28	13.96	4.25	59.41	0.30
	5.84 ± 0.15	3.05 ± 0.15	3.05 ± 0.15					
T5.95x2.8x2.5	5.95 ± 0.30	2.80 ± 0.30	2.50 ± 0.20	3.49	13.74	3.94	54.12	0.26
	5.95 ± 0.30	2.80 ± 0.30	2.50 ± 0.20					
T6x3x2	6.00 ± 0.30	3.00 ± 0.30	2.00 ± 0.20	4.71	14.14	3.00	42.41	0.21
	6.00 ± 0.30	3.00 ± 0.30	2.00 ± 0.20					
T6x3x3	6.00 ± 0.30	3.00 ± 0.30	3.00 ± 0.20	3.14	14.14	4.50	63.62	0.32
	6.00 ± 0.30	3.00 ± 0.30	3.00 ± 0.20					
T6x4x2.15	6.00 ± 0.30	4.00 ± 0.30	2.15 ± 0.20	7.31	15.71	2.15	33.70	0.17
	6.00 ± 0.30	4.00 ± 0.30	2.15 ± 0.20					
T6.22x2.8x3.38	6.22 ± 0.30	2.80 ± 0.30	3.38 ± 0.20	2.45	14.16	5.77	81.85	0.40
	6.22 ± 0.30	2.80 ± 0.30	3.38 ± 0.20					
T6.35x3.81x3.18	6.35 ± 0.30	3.81 ± 0.30	3.18 ± 0.20	3.95	15.96	4.04	64.45	0.30
	6.35 ± 0.30	3.81 ± 0.30	3.18 ± 0.20					
T6.5x3.5x2.3	6.50 ± 0.30	3.50 ± 0.25	2.30 ± 0.20	4.55	15.70	3.45	54.17	0.27
	6.50 ± 0.30	3.50 ± 0.25	2.30 ± 0.20					
T7.1x4.4x2.7	7.10 ± 0.30	4.40 ± 0.30	2.70 ± 0.30	1.35	18.06	3.65	66.00	0.31
	7.10 ± 0.30	4.40 ± 0.30	2.70 ± 0.30					
T7.62x3.18x4.8	7.62 ± 0.15	3.18 ± 0.15	4.80 ± 0.15	1.59	16.96	10.66	180.77	0.89
	7.62 ± 0.15	3.18 ± 0.15	4.80 ± 0.15					
T8x4x2	8.00 ± 0.30	4.00 ± 0.20	2.00 ± 0.20	4.71	18.85	4.00	75.40	0.37
	8.00 ± 0.30	4.00 ± 0.20	2.00 ± 0.20					
T8x4x4	8.00 ± 0.30	4.00 ± 0.20	4.00 ± 0.30	2.36	18.85	8.00	150.80	0.76
	8.00 ± 0.30	4.00 ± 0.20	4.00 ± 0.30					
T8x4.5x4	8.00 ± 0.30	4.50 ± 0.20	4.00 ± 0.30	2.80	19.63	7.00	137.44	0.65
	8.00 ± 0.30	4.50 ± 0.20	4.00 ± 0.30					
T8.15x4.3x4.05	8.15 ± 0.30	4.30 ± 0.30	4.05 ± 0.30	2.51	19.56	7.80	152.47	0.75
	8.15 ± 0.30	4.30 ± 0.30	4.05 ± 0.30					
T8.35x3.33x4.18	8.35 ± 0.30	3.33 ± 0.20	4.18 ± 0.20	1.74	18.33	10.49	192.39	0.93
	8.35 ± 0.30	3.33 ± 0.20	4.18 ± 0.20					
T8.89x3.81x4.83	8.89 ± 0.15	3.81 ± 0.15	4.83 ± 0.15	1.62	19.39	12.26	244.61	1.16
	8.89 ± 0.15	3.81 ± 0.15	4.83 ± 0.15					



MANUFACTURING CAPABILITY

Gapped Toroid Sizes(OD)	2.50mm - 12.00mm
Height	0.70mm - 8.00mm
Gap Sizes :	0.03mm - 0.80mm
AL Tolerance	AL ± 10%

APPLICATIONS

- Power**
 - DC-DC Converters
 - Compact Power Transformer
 - Small, Low Profile Power Inductors
- Telecom**
 - xDSL pass-band Filiterers
 - Spilters
 - EMI Inductors
 - Filiter Inductors with Tight Tolerance

■ ELECTRICAL CHARACTERISTICS

CORES	AL ± 25% (nH/N ²)						AL ± 30% (nH/N ²)				
	P4	P47	P5	N42	A043	A05	A07	A10	A102	A121	A151
T5.33x3.12x1.98											3100
T5.4x2.6x2										3360	
T5.84x3.05x1.52	490	570		725	860	980	1370	1960	1960	2290	2860
T5.84x3.05x3.05	990		765		1720	1980	2770	3960	3960	4600	5750
T5.95x2.8x2.5										4320	5400
T6x3x2	660		530		1200	1450	2200	2600	2600	3200	4000
T6x3x3	1000	1200	800	1520	1800	2200	2800	4000	4000	4800	6000
T6x4x2.15	430		340		700	870	1200	1740	1740	2080	
T6.22x2.8x3.38	1280	1540		1950		2560		5130	5130		
T6.35x3.81x3.18	790	950	630	1210		1590	2220	3180	3180	3820	
T6.5x3.5x2.3	690					1380	1930				4140
T7.1x4.4x2.7					1140	1260					
T7.62x3.18x4.8	2090			3000		4175	5845	8350	8350	9480	11850
T8x4x2	660	800	550		1200	1330	1870	2670	2670	3200	4000
T8x4x4	1300			2030	2400	2650	3700	5300	5300	6400	8000
T8x4.5x4	1100		900			2200	3100	4450	4450	5380	6725
T8.15x4.3x4.05	1300							5010	5010	6015	7520
T8.35x3.33x4.18				2730		3600	5030	7185	7185	8625	10790
T8.89x3.81x4.83	1930										11600

Remark:

1. AL Value Testing Condition : 10kHz, 50mV, 1Ts. If testing condition is different from ACME's, please specify upon request & ordering.

2. Coating Material

(1) Toroid Size T8 and Below:clear parylene coating, breakdown voltage:1000Vdc, coating thickness : 0.05mm max.

(2) Toroid Size T9 and Above:green epoxy coating, breakdown voltage:1500Vdc, coating thickness : 0.6mm max.

Type : T Cores

Ordering Code:

Shape:

A05	T9*5*3	C	G□
Material 材質	Core Size 品名	Coating 塗裝	Gapped AL Value

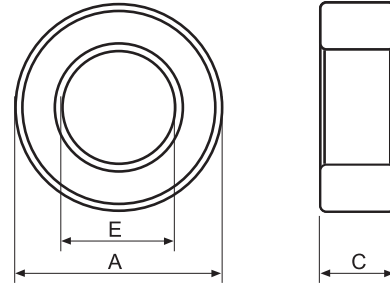

C : Epoxy Coating of Halogen-Free UC : Epoxy Coating of UL & Halogen
 HP : Parylene Coating of Halogen-Free P : Parylene Coating of Halogen

■ DIMENSIONS AND EFFECTIVE PARAMETERS

CORES	DIMENSIONS (mm)			EFFECTIVE PARAMETERS				
	EPOXY COATING DIMENSIONS (mm)			Ci(mm ⁻¹)	Le(mm)	Ae(mm ²)	Ve(mm ³)	Wt(g/set)
	A	E	C					
T9x5x3	9.10 ± 0.30	5.10 ± 0.30	3.00 ± 0.30	3.67	21.99	6.00	131.95	0.60
	10.00max	4.20min	3.90max					
T9x5x5	9.10 ± 0.30	5.10 ± 0.30	5.00 ± 0.30	2.20	21.99	10.00	219.91	1.00
	10.00max	4.20min	5.90max					
T9x5x5.5	9.10 ± 0.30	5.10 ± 0.30	5.50 ± 0.30	2.00	21.99	11.00	241.90	1.09
	10.00max	4.20min	6.40max					
T9x5x7	9.10 ± 0.30	5.10 ± 0.30	7.00 ± 0.30	1.57	21.99	14.00	307.88	1.41
	10.00max	4.20min	7.90max					
T9x6x3	8.90 ± 0.30	6.00 ± 0.30	3.00 ± 0.30	5.38	23.40	4.35	101.79	0.60
	9.80max	5.10min	3.90max					
T9x6x5	8.90 ± 0.30	6.00 ± 0.30	5.00 ± 0.30	3.23	23.40	7.25	169.69	0.86
	9.80max	5.10min	5.90max					
T9.5x3x1.7	9.50 ± 0.40	3.00 ± 0.30	1.70 ± 0.20	3.55	19.64	5.53	108.61	0.51
	10.50max	2.10min	2.50max					
T9.53x4.75x3.2	9.53 ± 0.25	4.75 ± 0.25	3.20 ± ^{+0.13} / _{-0.12}	2.93	22.43	7.65	171.55	0.80
	10.38max	3.90min	3.93max					
T9.53x4.75x4.8	9.53 ± 0.25	4.75 ± ^{+0.13} / _{-0.12}	4.80 ± ^{+0.13} / _{-0.12}	1.96	22.43	11.47	257.30	1.09
	10.38max	4.03min	5.53max					
T9.53x4.75x4.9	9.53 ± 0.25	4.75 ± ^{+0.13} / _{-0.12}	4.90 ± ^{+0.13} / _{-0.12}	1.92	22.43	11.71	262.69	1.11
	10.38max	4.03min	5.63max					
T9.53x4.75x6.35	9.53 ± 0.20	4.75 ± 0.20	6.35 ± 0.18	1.49	22.43	15.06	337.74	1.62
	10.33max	3.95min	7.13max					
T9.53x5.59x3.2	9.53 ± 0.30	5.59 ± 0.25	3.20 ± ^{+0.13} / _{-0.12}	3.77	23.75	6.30	149.72	0.75
	10.43max	4.74min	3.93max					
T9.53x5.59x4	9.53 ± 0.30	5.59 ± 0.25	4.00 ± ^{+0.13} / _{-0.12}	3.01	23.75	7.88	187.15	0.91
	10.43max	4.74min	4.73max					
T9.53x5.59x4.9	9.53 ± 0.30	5.59 ± 0.25	4.90 ± ^{+0.13} / _{-0.12}	2.46	23.75	9.65	229.26	1.14
	10.43max	4.74min	5.63max					
T9.53x5.59x7.11	9.53 ± 0.30	5.59 ± 0.25	7.11 ± 0.25	1.70	23.75	14.01	332.67	1.61
	10.43max	4.74min	8.01max					



MANUFACTURING CAPABILITY

Gapped Toroid Sizes(OD)	2.50mm - 12.00mm
Height	0.70mm - 8.00mm
Gap Sizes :	0.03mm - 0.80mm
AL Tolerance	AL ± 10%

APPLICATIONS

- Power**
 - DC-DC Converters
 - Compact Power Transformer
 - Small, Low Profile Power Inductors
- Telecom**
 - xDSL pass-band Filiterers
 - Spilters
 - EMI Inductors
 - Filiter Inductors with Tight Tolerance

■ ELECTRICAL CHARACTERISTICS

CORES	AL ± 25% (nH/N ²)						AL ± 30% (nH/N ²)			
	P4	P47	P5	N42	A05	A07	A10	A102	A121	A151
T9x5x3	880	1020	680	1300	1760	2470	3520	3520	4060	5070
T9x5x5	1469		1130		2938	4114	5887	5887	6765	8460
T9x5x5.5	1616				3232	4525	6465	6465		
T9x5x7	2057		1600		4114	5760	8229	8229		
T9x6x3	585		440		1170	1635	2330	2330		
T9x6x5	980						3890	3890		
T9.5x3x1.7							3540	3540		
T9.53x4.75x3.2	1110	1285	855	1630	2230	3120	4450	4450	5140	6430
T9.53x4.75x4.8	1670			2450	3340	4680	6680	6680	7720	9600
T9.53x4.75x4.9	1730				3460	4840	6920	6920	7880	9845
T9.53x4.75x6.35	2190			3330	4380	6140	8770	8770	10210	12760
T9.53x5.59x3.2	850		670		1700	2380	3400	3400		
T9.53x5.59x4						2920	4170	4170		
T9.53x5.59x4.9	1300				2610	3650	5220	5220	6130	7660
T9.53x5.59x7.11	1900				3790	5310	7590	7590		

Remark:

1. AL Value Testing Condition : 10kHz, 50mV, 1Ts. If testing condition is different from ACME's, please specify upon request & ordering.
2. Coating Material
 - (1) Toroid Size T8 and Below:clear parylene coating, breakdown voltage:1000Vdc, coating thickness : 0.05mm max.
 - (2) Toroid Size T9 and Above:green epoxy coating, breakdown voltage:1500Vdc, coating thickness : 0.6mm max.

Type : T Cores

Ordering Code:

Shape:

A05	T10*5*3	C	G□
Material 材質	Core Size 品名	Coating 塗裝	Gapped AL Value

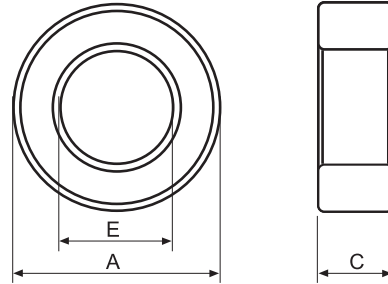

C : Epoxy Coating of Halogen-Free UC : Epoxy Coating of UL & Halogen
 HP : Parylene Coating of Halogen-Free P : Parylene Coating of Halogen

■ DIMENSIONS AND EFFECTIVE PARAMETERS

CORES	DIMENSIONS (mm)			EFFECTIVE PARAMETERS				
	EPOXY COATING DIMENSIONS (mm)			Ci(mm ⁻¹)	Le(mm)	Ae(mm ²)	Ve(mm ³)	Wt(g/set)
A	E	C						
T10x5x2.3	10.00 ± 0.20	5.00 ± 0.13	2.30 ± 0.13	4.10	23.56	5.75	135.48	0.66
	10.80max	4.27min	3.03max					
T10x5x3	10.00 ± 0.20	5.00 ± 0.13	3.00 ± 0.13	3.14	23.56	7.50	176.71	0.84
	10.80max	4.27min	3.73max					
T10x5x5	10.00 ± 0.20	5.00 ± 0.13	5.00 ± 0.13	1.88	23.56	12.50	294.52	1.41
	10.80max	4.27min	5.73max					
T10x6x2.78	10.10 ± 0.30	6.10 ± 0.30	2.78 ± 0.30	4.52	25.13	5.56	139.74	0.67
	11.00max	5.20min	3.68max					
T10x6x4	10.10 ± 0.30	6.10 ± 0.30	4.00 ± 0.30	3.14	25.13	8.00	201.06	0.98
	11.00max	5.20min	4.90max					
T10x6x5	10.10 ± 0.30	6.10 ± 0.30	5.00 ± 0.30	2.51	25.13	10.00	251.33	1.25
	11.00max	5.20min	5.90max					
T10x6x6	10.10 ± 0.30	6.10 ± 0.30	6.00 ± 0.30	2.09	25.13	12.00	301.59	1.48
	11.00max	5.20min	6.90max					
T10.6x5.2x4.4	10.60 ± 0.30	5.20 ± 0.30	4.40 ± 0.20	2.09	24.82	11.88	294.84	1.41
	11.50max	4.30min	5.20max					
T11.5x7.5x3.6	11.50 ± 0.30	7.50 ± 0.30	3.60 ± 0.30	4.08	28.96	7.09	205.33	1.08
	12.00 ± 0.50	7.00 ± 0.50	4.00 ± 0.50					
T12x6x4	12.00 ± 0.40	6.00 ± 0.30	4.00 ± 0.30	2.36	28.27	12.00	339.29	1.50
	13.00max	5.10min	4.90max					
T12x7.15x6	12.00 ± 0.40	7.15 ± 0.30	6.00 ± 0.30	2.07	30.08	14.55	437.66	2.06
	13.00max	6.25min	6.90max					
T12.4x7.8x3.75	12.40 ± 0.40	7.80 ± 0.30	3.75 ± 0.30	3.51	31.57	9.00	284.13	1.34
	13.40max	6.90min	4.65max					
T12.5x7.5x5	12.50 ± 0.30	7.50 ± 0.30	5.00 ± 0.30	2.51	31.42	12.50	392.76	1.93
	13.40max	6.60min	5.90max					
T12.7x5.16x6.35	12.70 ± 0.40	5.16 ± 0.30	6.35 ± 0.30	1.17	28.04	23.94	671.28	3.21
	13.70max	4.26min	7.25max					
T12.7x7.14x4.78	12.70 ± 0.40	7.14 ± 0.30	4.78 ± 0.30	2.35	31.16	13.29	414.13	2.00
	13.70max	6.24min	5.68max					
T12.7x7.14x6.35	12.70 ± 0.40	7.14 ± 0.30	6.35 ± 0.30	1.77	31.16	17.65	550.15	2.67
	13.70max	6.24min	7.25max					



MANUFACTURING CAPABILITY

Gapped Toroid Sizes(OD)	2.50mm - 12.00mm
Height	0.70mm - 8.00mm
Gap Sizes :	0.03mm - 0.80mm
AL Tolerance	AL ± 10%

APPLICATIONS

- Power**
 - DC-DC Converters
 - Compact Power Transformer
 - Small, Low Profile Power Inductors
- Telecom**
 - xDSL pass-band Filiterers
 - Spilters
 - EMI Inductors
 - Filiter Inductors with Tight Tolerance

■ ELECTRICAL CHARACTERISTICS

CORES	AL ± 25% (nH/N ²)						AL ± 30% (nH/N ²)			
	P4	P47	P5	N42	A05	A07	A10	A102	A121	A151
T10x5x2.3	760									
T10x5x3	1000				2000	2800	4000	4000	4800	6000
T10x5x5	1650		1330		3300	4650	6650	6650	8000	10000
T10x6x2.78	680		550		1350	1900	2740	2740	3300	4120
T10x6x4	1020		800	1500	2040	2850	4080	4080	4900	5930
T10x6x5	1270		990	1900	2550	3570	5100	5100	5820	7410
T10x6x6	1530		1220		3060	4290	6130	6130	7350	8895
T10.6x5.2x4.4	1500		1200		3000	4200	6000	6000		
T11.5x7.5x3.6						2120				
T12x6x4	1350				2700	3800	5400	5400	6000	8000
T12x7.15x6					3040					
T12.4x7.8x3.75					1790		3420	3420		5130
T12.5x7.5x5	1250		1000		2500	3500	5000	5000		
T12.7x5.16x6.35							10730	10730		
T12.7x7.14x4.78	1340				2680	3750	5360	5360	6430	8040
T12.7x7.14x6.35	1780		1420		3560	4985	7120	7120	8550	10685

Remark:

1. AL Value Testing Condition : 10kHz, 50mV, 1Ts. If testing condition is different from ACME's, please specify upon request & ordering.
2. Coating Material
 - (1) Toroid Size T8 and Below:clear parylene coating, breakdown voltage:1000Vdc, coating thickness : 0.05mm max.
 - (2) Toroid Size T9 and Above:green epoxy coating, breakdown voltage:1500Vdc, coating thickness : 0.6mm max.

Type : T Cores

Ordering Code:

Shape:

P4	T12.7*7.92*4.7	C	G□
Material 材質	Core Size 品名	Coating 塗裝	Gapped AL Value

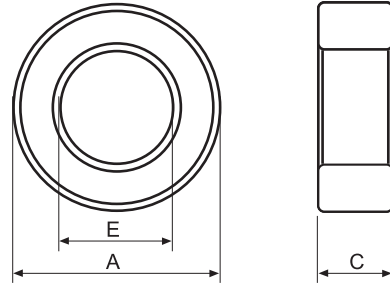

C : Epoxy Coating of Halogen-Free UC : Epoxy Coating of UL & Halogen
 HP : Parylene Coating of Halogen-Free P : Parylene Coating of Halogen

■ DIMENSIONS AND EFFECTIVE PARAMETERS

CORES	DIMENSIONS (mm)			EFFECTIVE PARAMETERS				
	EPOXY COATING DIMENSIONS (mm)			C _i (mm ⁻¹)	L _e (mm)	A _e (mm ²)	V _e (mm ³)	Wt(g/set)
	A	E	C					
T12.7x7.92x4.7	12.70 ± 0.40	7.92 ± 0.30	4.70 ± 0.30	2.98	32.08	10.76	345.23	1.61
	13.70max	7.02min	5.60max					
T12.7x7.92x4.9	12.70 ± 0.40	7.92 ± 0.30	4.90 ± 0.30	2.86	32.08	11.22	359.92	1.70
	13.70max	7.02min	5.80max					
T12.7x7.92x5.2	12.70 ± 0.40	7.92 ± 0.30	5.20 ± 0.30	2.69	32.08	11.91	381.96	1.80
	13.70max	7.02min	6.10max					
T12.7x7.92x6.35	12.70 ± 0.40	7.92 ± 0.30	6.35 ± 0.30	2.22	32.08	14.43	462.76	2.33
	13.70max	7.02min	7.25max					
T12.7x7.92x7	12.70 ± 0.40	7.92 ± 0.30	7.00 ± 0.30	2.00	32.08	16.03	514.17	2.40
	13.70max	7.02min	7.90max					
T12.7x8.12x5.08	12.70 ± 0.40	8.12 ± 0.30	5.08 ± 0.30	2.80	32.68	11.63	380.25	1.82
	13.70max	7.22min	5.98max					
T12.85x7.35x5	12.85 ± 0.40	7.35 ± 0.30	5.00 ± 0.30	2.31	31.73	13.75	436.29	2.14
	13.85max	6.45min	5.90max					
T13.21x7.37x3.96	13.21 ± 0.40	7.37 ± 0.30	3.96 ± 0.30	2.80	32.33	11.56	373.80	1.81
	14.21max	6.47min	4.86max					
T13.3x7.1x12.7	13.30 ± 0.40	7.10 ± 0.40	12.70 ± 0.30	0.79	30.03	38.10	1144.33	6.17
	14.30max	6.10min	13.60max					
T13.3x8.3x5	13.30 ± 0.30	8.30 ± 0.30	5.00 ± 0.30	2.71	33.93	12.50	424.12	2.09
	14.20max	7.40min	5.90max					
T14x7x7	14.00 ± 0.40	7.00 ± 0.30	7.00 ± 0.30	1.35	32.99	24.50	808.17	3.88
	15.00max	6.10min	7.90max					
T14x7.5x7	14.00 ± 0.40	7.50 ± 0.30	7.00 ± 0.30	1.48	33.77	22.75	768.32	3.69
	15.00max	6.60min	7.90max					
T14x8x4	14.00 ± 0.40	8.00 ± 0.30	4.00 ± 0.30	2.88	34.56	12.00	414.69	1.97
	15.00max	7.10min	4.90max					
T14x8x7	14.00 ± 0.40	8.00 ± 0.30	7.00 ± 0.30	1.65	34.56	21.00	725.71	3.45
	15.00max	7.10min	7.90max					
T14x8x9	14.00 ± 0.40	8.00 ± 0.30	9.00 ± 0.30	1.28	34.56	27.00	933.05	4.48
	15.00max	7.10min	9.90max					



MANUFACTURING CAPABILITY

Gapped Toroid Sizes(OD)	12.00mm - 38.00mm
Height	3.00mm - 15.00mm
Gap Sizes :	0.45mm - 2.00mm
AL Tolerance	AL ± 10%

APPLICATIONS

- Power**
 - DC-DC Converters
 - Compact Power Transformer
 - Small, Low Profile Power Inductors
- Telecom**
 - xDSL pass-band Filiterers
 - Spilters
 - EMI Inductors
 - Filiter Inductors with Tight Tolerance

■ ELECTRICAL CHARACTERISTICS

CORES	AL ± 25% (nH/N ²)						AL ± 30% (nH/N ²)			
	P4	P47	P5	N42	A05	A07	A10	A102	A121	A151
T12.7x7.92x4.7	1100				2220	3110	4460	4460		
T12.7x7.92x4.9	1156				2310	3240	4630	4630	5456	
T12.7x7.92x5.2	1227			1830	2455	3437	4910	4910		
T12.7x7.92x6.35	1487			2240	2990	4190	5950	5950	7070	8840
T12.7x7.92x7	1653	1950	1290		3300	4650	6610	6610	7795	9740
T12.7x8.12x5.08					2200		4470	4470		
T12.85x7.35x5	1400				2790	3910	5580	5580	6540	8170
T13.21x7.37x3.96					2250	3150	4500	4500		
T13.3x7.1x12.7										22000
T13.3x8.3x5	1150		900		2300	3200	4600	4600	5500	6800
T14x7x7					4670	6540	9300	9300	11210	14000
T14x7.5x7					4230	5930	8400	8400	10160	12700
T14x8x4	1119		870		2240	3130	4480	4480	5240	6550
T14x8x7	1956				3920	5480	7840	7840	9170	11460
T14x8x9	2510				5040	7045	10080	10080	11790	14730

Remark:

1. AL Value Testing Condition : 10kHz, 50mV, 1Ts. If testing condition is different from ACME's, please specify upon request & ordering.
2. Coating Material
 - (1) Toroid Size T8 and Below:clear parylene coating, breakdown voltage:1000Vdc, coating thickness : 0.05mm max.
 - (2) Toroid Size T9 and Above:green epoxy coating, breakdown voltage:1500Vdc, coating thickness : 0.6mm max.

Type : T Cores

Ordering Code:

Shape:

A10	T14*8.4*4	C	G□
Material 材質	Core Size 品名	Coating 塗裝	Gapped AL Value

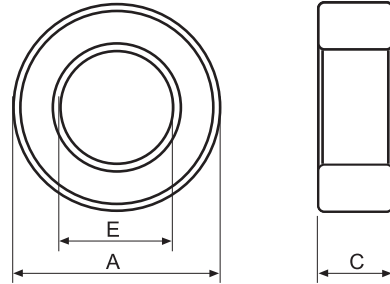

C : Epoxy Coating of Halogen-Free UC : Epoxy Coating of UL & Halogen
 HP : Parylene Coating of Halogen-Free P : Parylene Coating of Halogen

■ DIMENSIONS AND EFFECTIVE PARAMETERS

CORES	DIMENSIONS (mm)			EFFECTIVE PARAMETERS				
	EPOXY COATING DIMENSIONS (mm)			C _i (mm ³)	L _e (mm)	A _e (mm ²)	V _e (mm ³)	Wt(g/set)
	A	E	C					
T14x8.4x4	14.00 ± 0.40	8.40 ± 0.30	4.00 ± 0.30	3.14	35.19	11.20	394.08	1.97
	15.00max	7.50min	4.90max					
T14x8.4x12	14.00 ± 0.40	8.40 ± 0.30	12.00 ± 0.30	1.05	35.19	33.60	1182.24	5.63
	15.00max	7.50min	12.90max					
T14x9x5	14.00 ± 0.40	9.00 ± 0.30	5.00 ± 0.30	2.89	36.13	12.50	451.60	2.08
	15.00max	8.10min	5.90max					
T14.3x9.7x6.3	14.30 ± 0.30	9.70 ± 0.30	6.30 ± 0.30	2.60	37.68	14.49	545.98	2.81
	15.20max	8.80min	7.20max					
T15.7x10.2x6.8	15.70 ± 0.40	10.20 ± 0.40	6.80 ± 0.30	2.14	39.45	18.42	726.37	3.70
	16.70max	9.20min	7.60max					
T15.88x8.89x4.7	15.88 ± 0.40	8.89 ± 0.30	4.70 ± 0.30	2.37	38.91	16.43	639.13	3.17
	16.88max	7.99min	5.60max					
T16x8x8	16.00 ± 0.30	8.00 ± 0.30	8.00 ± 0.30	1.18	37.70	32.00	1206.40	5.83
	16.90max	7.10min	8.90max					
T16x9x5	16.00 ± 0.40	9.50 ± 0.40	5.00 ± 0.30	2.24	39.27	17.50	687.22	3.19
	17.00max	8.50min	5.90max					
T16x9x8	16.00 ± 0.40	9.50 ± 0.40	8.00 ± 0.30	1.40	39.27	28.00	1099.56	4.94
	17.00max	8.50min	8.90max					
T16x9.6x6.1	16.00 ± 0.30	9.60 ± 0.30	6.10 ± 0.30	2.06	40.21	19.52	784.95	3.64
	16.90max	8.70min	7.00max					
T16x10x5	16.00 ± 0.30	10.00 ± 0.30	5.00 ± 0.30	2.72	40.84	15.00	612.60	2.96
	16.90max	9.10min	5.90max					
T16x12x7	16.00 ± 0.30	12.00 ± 0.30	7.00 ± 0.30	3.14	43.98	14.00	615.75	2.86
	16.90max	11.10min	7.90max					
T16x12x8	16.00 ± 0.30	12.00 ± 0.30	8.00 ± 0.30	2.75	43.98	16.00	704.00	3.53
	16.90max	11.10min	8.90max					
T16.4x12x8	16.40 ± 0.30	12.00 ± 0.30	8.00 ± 0.30	2.53	44.61	17.60	785.15	3.80
	17.30max	11.10min	8.90max					
T17x10.6x6.8	17.00 ± 0.30	10.60 ± 0.30	6.80 ± 0.30	1.99	43.33	21.76	942.90	4.54
	17.90max	9.70min	7.70max					
T18x10x7	18.00 ± 0.30	10.00 ± 0.30	7.00 ± 0.30	1.57	43.98	28.00	1231.00	6.13
	18.90max	9.10min	7.90max					
T18x10x8	18.00 ± 0.30	10.00 ± 0.30	8.00 ± 0.30	1.37	43.98	32.00	1407.00	6.91
	18.90max	9.10min	8.90max					
T18x10x10	18.00 ± 0.30	10.00 ± 0.30	10.00 ± 0.30	1.10	43.98	40.00	1759.00	8.77
	18.90max	9.10min	10.90max					
T18x12x6	18.00 ± 0.30	11.90 ± 0.20	6.00 ± 0.20	2.62	47.12	18.00	848.22	4.16
	18.90max	11.10min	6.80max					

MANUFACTURING CAPABILITY

Gapped Toroid Sizes(OD)	12.00mm - 38.00mm
Height	3.00mm - 15.00mm
Gap Sizes :	0.45mm - 2.00mm
AL Tolerance	AL ± 10%

APPLICATIONS

- Power**
 - DC-DC Converters
 - Compact Power Transformer
 - Small, Low Profile Power Inductors
- Telecom**
 - xDSL pass-band Filiterers
 - Spilters
 - EMI Inductors
 - Filiter Inductors with Tight Tolerance

■ ELECTRICAL CHARACTERISTICS

CORES	AL ± 25% (nH/N ²)						AL ± 30% (nH/N ²)			
	P4	P47	P5	N42	A05	A07	A10	A102	A121	A151
T14x8.4x4	1020		800		2040	2860	4080	4080	4800	
T14x8.4x12	3060				6130	8580	12260	12260	14400	
T14x9x5	1100	1400	870		2210	3090	4420	4420	5220	6530
T14.3x9.7x6.3							4830	4830	5790	
T15.7x10.2x6.8						4600				
T15.88x8.89x4.7	1330		1060		2650	3710	5310	5310	6370	7960
T16x8x8						7500	10670	10670		
T16x9x5	1300	1530	1020	2000	2600	3650	5210	5210	6250	7650
T16x9x8	2040		1630		4080	5710	8160	8160	9700	12240
T16x9.6x6.1	1520		1220		3050	4270	6100	6100	7320	
T16x10x5							4620		5540	6925
T16x12x7	1000			1520	2000	2800	4020	4020		6000
T16x12x8	1150			1740	2300	3220	4600	4600	5400	6860
T16.4x12x8									5950	
T17x10.6x6.8	1580				3155	4420	6300	6300		
T18x10x7	2054				4110	5760	8230	8230	9600	12000
T18x10x8	2350				4700	6580	9400	9400	10980	13720
T18x10x10	2940				5880	8230	11750	11750	13720	17155
T18x12x6	1210				2430	3400	4860	4860	5760	7345

Remark:

1. AL Value Testing Condition : 10kHz, 50mV, 1Ts. If testing condition is different from ACME's, please specify upon request & ordering.
2. Coating Material
 - (1) Toroid Size T8 and Below:clear parylene coating, breakdown voltage:1000Vdc, coating thickness : 0.05mm max.
 - (2) Toroid Size T9 and Above:green epoxy coating, breakdown voltage:1500Vdc, coating thickness : 0.6mm max.

Type : T Cores

Ordering Code:

Shape:

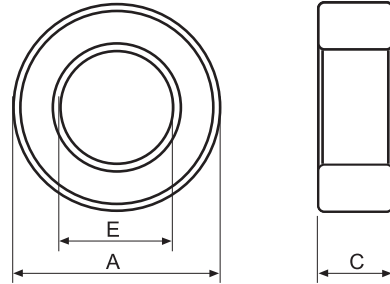
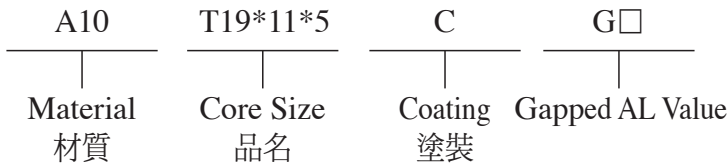

C : Epoxy Coating of Halogen-Free UC : Epoxy Coating of UL & Halogen
 HP : Parylene Coating of Halogen-Free P : Parylene Coating of Halogen

■ DIMENSIONS AND EFFECTIVE PARAMETERS

CORES	DIMENSIONS (mm)			EFFECTIVE PARAMETERS				
	EPOXY COATING DIMENSIONS (mm)			Ci(mm ³)	Le(mm)	Ae(mm ²)	Ve(mm ³)	Wt(g/set)
	A	E	C					
T19x11x5	19.00 ± 0.30	11.00 ± 0.30	5.00 ± 0.30	2.36	47.12	20.00	942.48	4.43
	19.90max	10.10min	5.90max					
T19x13x6	19.00 ± 0.30	13.00 ± 0.30	6.00 ± 0.20	2.79	50.27	18.00	904.78	6.13
	19.90max	12.10min	6.80max					
T19.3x10.2x10.4	19.30 ± 0.40	10.20 ± 0.30	10.40 ± 0.30	0.97	45.55	46.80	2131.88	10.55
	20.30max	9.30min	11.30max					
T20x10x7	20.00 ± 0.40	10.00 ± 0.40	7.00 ± 0.30	1.35	47.12	35.00	1649.34	8.05
	21.00max	9.00min	7.90max					
T20x10x10	20.00 ± 0.40	10.00 ± 0.40	10.00 ± 0.30	0.94	47.12	50.00	2356.19	11.24
	21.00max	9.00min	10.90max					
T20x10x12	20.00 ± 0.40	10.00 ± 0.40	12.00 ± 0.30	0.79	47.12	60.00	2827.43	13.53
	21.00max	9.00min	12.90max					
T20x11x10	20.00 ± 0.40	11.00 ± 0.40	10.00 ± 0.30	1.08	48.69	45.00	2191.26	10.29
	21.00max	10.00min	10.90max					
T20x11x15	20.00 ± 0.40	11.00 ± 0.40	15.00 ± 0.30	0.72	48.69	67.50	3286.89	15.23
	21.00max	10.00min	15.90max					
T20x12x8	20.00 ± 0.40	12.00 ± 0.40	8.00 ± 0.30	1.57	50.27	32.00	1608.64	9.17
	21.00max	11.00min	8.90max					
T22x11x7	22.00 ± 0.30	11.00 ± 0.30	7.00 ± 0.30	1.35	51.81	38.50	1994.69	9.74
	22.90max	10.10min	7.90max					
T22x14x6.5	22.00 ± 0.40	14.00 ± 0.40	6.50 ± 0.30	2.17	56.55	26.00	1470.27	6.77
	23.00max	13.00min	7.40max					
T22x14x8	22.00 ± 0.40	14.00 ± 0.40	8.00 ± 0.30	1.77	56.55	32.00	1809.56	8.61
	23.00max	13.00min	8.90max					
T22x14x9	22.00 ± 0.40	14.00 ± 0.40	9.00 ± 0.30	1.57	56.55	36.00	2035.75	9.77
	23.00max	13.00min	9.90max					
T22x14x10	22.00 ± 0.40	14.00 ± 0.40	10.00 ± 0.30	1.41	56.55	40.00	2261.95	11.33
	23.00max	13.00min	10.90max					
T22x14x12.7	22.00 ± 0.40	14.00 ± 0.40	12.70 ± 0.30	1.11	56.55	50.80	2872.67	14.04
	23.00max	13.00min	13.60max					
T22.1x13.72x6.35	22.10 ± 0.40	13.72 ± 0.40	6.35 ± 0.30	2.11	56.27	26.61	1497.04	7.04
	23.10max	12.72min	7.25max					
T23x11x6	23.00 ± 0.40	11.00 ± 0.40	6.00 ± 0.30	1.48	53.41	36.00	1022.65	9.40
	24.00max	10.00min	6.90max					
T23x14x7	23.00 ± 0.40	14.00 ± 0.40	7.00 ± 0.30	1.85	58.11	31.50	1830.76	8.53
	24.00max	13.00min	7.90max					
T24x18x6	24.00 ± 0.40	18.00 ± 0.40	6.00 ± 0.30	3.64	65.07	17.88	1163.25	5.61
	25.00max	17.00min	6.90max					



MANUFACTURING CAPABILITY

Gapped Toroid Sizes(OD)	12.00mm - 38.00mm
Height	3.00mm - 15.00mm
Gap Sizes :	0.45mm - 2.00mm
AL Tolerance	AL ± 10%

APPLICATIONS

- Power**
 - DC-DC Converters
 - Compact Power Transformer
 - Small, Low Profile Power Inductors
- Telecom**
 - xDSL pass-band Filiterers
 - Spilters
 - EMI Inductors
 - Filiter Inductors with Tight Tolerance

■ ELECTRICAL CHARACTERISTICS

CORES	AL ± 25% (nH/N ²)						AL ± 30% (nH/N ²)			
	P4	P47	P5	N42	A05	A07	A10	A102	A121	A151
T19x11x5					2670	3800				
T19x13x6	1100		900		2200	3100	4500	4500	5400	6750
T19.3x10.2x10.4	3210				6420	8990	12840	12840	15400	19260
T20x10x7	2335				4670	6540	9300	9300	11200	
T20x10x10	3330		2660		6670	9300	13300	13300	16000	19000
T20x10x12	4000						16000	16000	19000	
T20x11x10	3200		2300		5800	8100	11600	11600	13950	
T20x11x15	4790		3450		8700	12200	17400	17400		26000
T20x12x8							8000	8000		
T22x11x7	2340					6540	9330	9330		
T22x14x6.5	1473		1155		2940	4110	5870	5870	6930	8670
T22x14x8	1804	2130	1420		3620	5060	7230	7230	8340	10675
T22x14x9	2034				4070	5695	8135	8135	9600	12000
T22x14x10	2259		1780		4520	6330	9040	9040	10670	13340
T22x14x12.7	2886		2260		5740	8040	11480	11480	13560	16945
T22.1x13.72x6.35	1485				2970	4160	5950	5950	7130	8920
T23x11x6	2100									
T23x14x7	1730		1360		3470	4860	6950	6950	8180	
T24x18x6		1030								

Remark:

1. AL Value Testing Condition : 10kHz, 50mV, 1Ts. If testing condition is different from ACME's, please specify upon request & ordering.
2. Coating Material
 - (1) Toroid Size T8 and Below:clear parylene coating, breakdown voltage:1000Vdc, coating thickness : 0.05mm max.
 - (2) Toroid Size T9 and Above:green epoxy coating, breakdown voltage:1500Vdc, coating thickness : 0.6mm max.

Type : T Cores

Ordering Code:

Shape:

P5	T25*15*5	C	G□
Material 材質	Core Size 品名	Coating 塗裝	Gapped AL Value

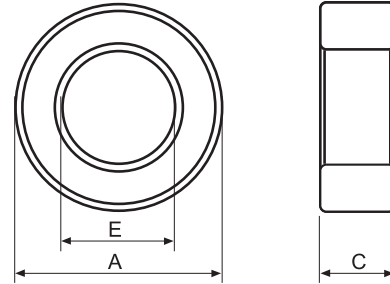

C : Epoxy Coating of Halogen-Free UC : Epoxy Coating of UL & Halogen
 HP : Parylene Coating of Halogen-Free P : Parylene Coating of Halogen

■ DIMENSIONS AND EFFECTIVE PARAMETERS

CORES	DIMENSIONS (mm)			EFFECTIVE PARAMETERS				
	EPOXY COATING DIMENSIONS (mm)			Ci(mm ⁻¹)	Le(mm)	Ae(mm ²)	Ve(mm ³)	Wt(g/set)
	A	E	C					
T25x9x2.5	25.00 ± 0.40	9.00 ± 0.40	2.50 ± 0.30	2.67	53.41	20.00	1068.20	5.17
	26.00max	8.00min	3.40max					
T25x15x5	25.00 ± 0.40	15.00 ± 0.40	5.00 ± 0.30	2.51	62.83	25.00	1570.80	7.44
	26.00max	14.00min	5.90max					
T25x15x8	25.00 ± 0.40	15.00 ± 0.40	8.00 ± 0.30	1.57	62.83	40.00	2513.27	12.06
	26.00max	14.00min	8.90max					
T25x15x9	25.00 ± 0.40	15.00 ± 0.40	9.00 ± 0.30	1.40	62.83	45.00	2827.43	13.63
	26.00max	14.00min	9.90max					
T25x15x10	25.00 ± 0.40	15.00 ± 0.40	10.00 ± 0.30	1.26	62.83	50.00	3141.59	14.89
	26.00max	14.00min	10.90max					
T25x15x12	25.00 ± 0.40	15.00 ± 0.40	12.00 ± 0.30	1.05	62.83	60.00	3769.91	17.95
	26.00max	14.00min	12.90max					
T25x15x13	25.00 ± 0.40	15.00 ± 0.40	13.00 ± 0.30	0.97	62.83	65.00	4084.07	19.43
	26.00max	14.00min	13.90max					
T25x15x15	25.00 ± 0.40	15.00 ± 0.40	15.00 ± 0.30	0.84	62.83	75.00	4172.39	23.30
	26.00max	14.00min	15.90max					
T25.4x15.5x10	25.40 ± 0.40	15.50 ± 0.40	10.00 ± 0.30	1.30	64.25	49.50	3180.16	15.71
	26.40max	14.50min	10.90max					
T26x14.5x10	26.00 ± 0.40	14.50 ± 0.30	10.00 ± 0.30	1.11	63.59	57.50	3656.43	17.34
	27.00max	13.60min	10.90max					
T26.4x14.5x10.2	26.40 ± 0.40	14.50 ± 0.40	10.20 ± 0.30	1.05	64.21	60.69	3897.08	18.76
	27.40max	13.50min	11.10max					
T28x16x13	28.00 ± 0.50	16.00 ± 0.40	13.00 ± 0.40	0.89	69.12	78.00	5391.36	26.30
	29.10max	15.00min	14.00max					
T28x18x16	28.00 ± 0.50	18.00 ± 0.40	16.00 ± 0.40	0.90	72.26	80.00	5780.80	27.97
	29.10max	17.00min	17.00max					
T29x19x7.49	29.00 ± 0.50	19.00 ± 0.35	7.49 ± 0.15	2.01	75.40	37.45	2823.66	12.90
	30.10max	18.05min	8.24max					
T29x19x15.2	29.00 ± 0.50	19.00 ± 0.35	15.20 ± 0.30	0.99	75.40	76.00	5730.27	27.73
	30.10max	18.05min	16.00max					
T31x19x6	31.00 ± 0.50	19.00 ± 0.50	6.00 ± 0.30	2.18	78.54	36.00	2827.43	13.22
	32.10max	17.90min	6.90max					
T31x19x8	31.00 ± 0.50	19.00 ± 0.50	8.00 ± 0.30	1.64	78.54	48.00	3769.91	18.12
	32.10max	17.90min	8.90max					
T31x19x12	31.00 ± 0.50	19.00 ± 0.50	12.00 ± 0.40	1.09	78.54	72.00	5654.87	26.99
	32.10max	17.90min	13.00max					
T31x19x13	31.00 ± 0.50	19.00 ± 0.50	13.00 ± 0.40	1.01	78.54	78.00	6126.11	29.04
	32.10max	17.90min	14.00max					
T31x19x16	31.00 ± 0.50	19.00 ± 0.50	16.00 ± 0.40	0.82	78.54	96.00	7539.82	35.74
	32.10max	17.90min	17.00max					



MANUFACTURING CAPABILITY

Gapped Toroid Sizes(OD)	12.00mm - 38.00mm
Height	3.00mm - 15.00mm
Gap Sizes :	0.45mm - 2.00mm
AL Tolerance	AL ± 10%

APPLICATIONS

- Power**
 - DC-DC Converters
 - Compact Power Transformer
 - Small, Low Profile Power Inductors
- Telecom**
 - xDSL pass-band Filiterers
 - Spilters
 - EMI Inductors
 - Filiter Inductors with Tight Tolerance

■ ELECTRICAL CHARACTERISTICS

CORES	AL ± 25% (nH/N ²)						AL ± 30% (nH/N ²)			
	P4	P47	P5	N42	A05	A07	A10	A102	A121	A151
T25x9x2.5		1550(P46)	706(P51)							
T25x15x5	1250		1000		2500	3500	5000	5000	6000	7500
T25x15x8	2040		1600	3040	4090	5720	8200	8200	9600	12010
T25x15x9	2300				4600	6440	9200	9200	10800	
T25x15x10	2550		2000	3800	5110	7150	10220	10220	11000	15010
T25x15x12	3064				6130	8580	12260	12260	14400	18010
T25x15x13	3322				6640	9300	13270	13270	15600	19510
T25x15x15	3830				7660	10730	15330	15330	17500	22500
T25.4x15.5x10	2420		1940		4840		9680	9680		14530
T26x14.5x10					5680					
T26.4x14.5x10.2					5940		11880	11880		
T28x16x13	3550					9900	14110	14110	17000	
T28x18x16					6960					
T29x19x7.49	1580				3170	4430	6340	6340	7495	
T29x19x15.2	3220		2500		6440	9020	12890	12890	15200	
T31x19x6	1465				2940	4110	5880	5880		
T31x19x8	1965		1560		3920	5480	7830	7830	9220	
T31x19x12	2930				5870	8220	11740	11740		
T31x19x13	3180		2500		6360	8910	12730	12730	14500	
T31x19x16	3840				7685	10760	15200	15200	18400	

Remark:

1. AL Value Testing Condition : 10kHz, 50mV, 1Ts. If testing condition is different from ACME's, please specify upon request & ordering.
2. Coating Material
 - (1) Toroid Size T8 and Below:clear parylene coating, breakdown voltage:1000Vdc, coating thickness : 0.05mm max.
 - (2) Toroid Size T9 and Above:green epoxy coating, breakdown voltage:1500Vdc, coating thickness : 0.6mm max.

Type : T Cores

Ordering Code:

Shape:

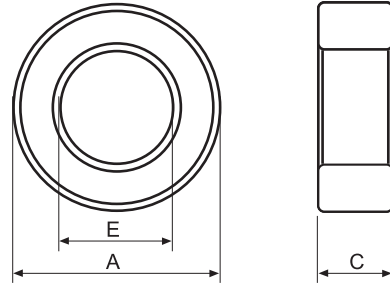
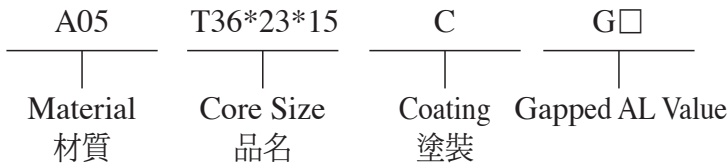

C : Epoxy Coating of Halogen-Free UC : Epoxy Coating of UL & Halogen
 HP : Parylene Coating of Halogen-Free P : Parylene Coating of Halogen

■ DIMENSIONS AND EFFECTIVE PARAMETERS

CORES	DIMENSIONS (mm)			EFFECTIVE PARAMETERS				
	EPOXY COATING DIMENSIONS (mm)			C _i (mm ⁻¹)	Le(mm)	Ae(mm ²)	Ve(mm ³)	Wt(g/set)
	A	E	C					
T34.4x20.2x12.6	34.40 ± 0.50	20.20 ± 0.50	12.60 ± 0.40	0.95	85.72	89.46	7668.69	36.92
	35.50max	19.10min	13.60max					
T36x23x15	36.00 ± 0.60	23.45 ± 0.50	15.00 ± 0.40	0.95	92.68	97.50	9036.01	41.37
	37.20max	22.35min	16.00max					
T36x25x11.3	36.00 ± 0.50	25.00 ± 0.40	11.30 ± 0.30	1.54	95.81	62.15	5954.59	27.30
	37.10max	24.00min	12.20max					
T36x26x10	36.00 ± 0.60	26.00 ± 0.50	10.00 ± 0.40	1.95	97.38	50.00	4869.00	19.50
	37.20max	24.90min	11.00max					
T37x22x15	37.00 ± 0.60	22.00 ± 0.50	15.00 ± 0.40	0.82	92.68	112.00	10426.16	50.51
	38.20max	20.90min	16.00max					
T38x19x13	38.10 ± 0.60	19.05 ± 0.60	13.00 ± 0.30	0.72	89.54	123.50	11057.62	53.19
	39.30max	17.85min	13.90max					
T38x20.5x13.8	38.00 ± 0.50	20.50 ± 0.30	13.80 ± 0.30	0.76	91.89	120.75	11095.90	52.20
	39.10max	19.60min	14.80max					
T38x22x14	38.00 ± 0.60	22.00 ± 0.60	14.00 ± 0.40	0.82	89.71	109.25	9801.55	50.07
	39.20max	20.80min	15.00max					
T40x5.3x1.0	40.00 ± 0.80	5.30 ± 0.40	1.00 ± 0.10	3.11	38.79	12.48	484.11	5.98
	41.40max	4.30min	1.70max					
T40x25x20	40.00 ± 0.80	25.00 ± 0.80	20.00 ± 0.40	0.68	102.10	150.00	15315.00	73.00
	41.40max	23.60min	21.00max					
T42x26x12.8	42.00 ± 0.80	26.00 ± 0.80	12.80 ± 0.40	1.04	106.76	102.40	10932.22	52.07
	43.40max	24.60min	13.80max					
T47x27x15	47.00 ± 0.80	27.00 ± 0.60	15.00 ± 0.40	0.77	116.24	150.00	17435.82	82.03
	48.40max	25.80min	16.00max					
T48x30x15	48.00 ± 0.80	30.00 ± 0.80	15.00 ± 0.40	0.91	122.46	135.00	16532.10	79.39
	49.40max	28.60min	16.00max					
T49.1x33.8x15.9	49.10 ± 1.00	33.80 ± 1.00	15.90 ± 0.40	1.07	130.15	121.64	15831.45	76.17
	50.70max	32.20min	16.90max					
T50x30x20	50.00 ± 1.00	30.00 ± 0.70	20.00 ± 0.50	0.63	125.66	200.00	25132.72	118.20
	51.50max	28.70min	21.10max					
T55.5x32.6x18	55.50 ± 1.10	32.60 ± 1.10	18.00 ± 0.50	0.67	138.32	206.10	28507.75	133.44
	57.20max	30.90min	19.10max					
T58.3x40.8x17.6	58.30 ± 1.60	40.80 ± 1.00	17.60 ± 0.50	1.01	155.67	154.00	23972.53	112.02
	60.50max	39.20min	18.70max					
T63x38x25	62.80 ± 1.60	37.60 ± 1.20	25.00 ± 0.60	0.51	158.65	312.50	49578.38	240.25
	65.00max	35.80min	26.20max					
T78x50.5x16	78.00 ± 1.50	50.50 ± 1.50	16.00 ± 0.50	0.92	201.75	220.00	44385.00	213.00
	80.10max	48.40min	17.10max					
T80x40x15	80.00 ± 1.50	40.00 ± 1.30	15.00 ± 0.60	0.60	174.21	288.27	50218.89	269.76
	82.10max	38.10min	16.20max					
T85x62x20	85.00 ± 1.70	62.00 ± 1.00	20.00 ± 0.80	1.00	226.87	227.85	51692.33	253.41
	87.30max	60.40min	21.40max					
T85.7x55.5x17.2	85.70 ± 1.50	55.50 ± 1.50	17.20 ± 0.40	1.16	221.68	191.77	42511.57	206.18
	87.80max	53.40min	18.20max					



MANUFACTURING CAPABILITY

Gapped Toroid Sizes(OD)	12.00mm - 38.00mm
Height	3.00mm - 15.00mm
Gap Sizes :	0.45mm - 2.00mm
AL Tolerance	AL ± 10%

APPLICATIONS

- Power**
 - DC-DC Converters
 - Compact Power Transformer
 - Small, Low Profile Power Inductors
- Telecom**
 - xDSL pass-band Filiterers
 - Spilters
 - EMI Inductors
 - Filiter Inductors with Tight Tolerance

■ ELECTRICAL CHARACTERISTICS

CORES	AL ± 25% (nH/N ₂)						AL ± 30% (nH/N ₂)			
	P4	P47	P5	N42	A05	A07	A10	A102	A121	A151
T34.4x20.2x12.6					6560					
T36x23x15	3210			4820	6430	9000	12860	12860	14500	
T36x25x11.3	2100									
T36x26x10	1650									
T37x22x15	3900				7790	10900	15500	15500	13000min	
T38x19x13	4200		3350		8400	11800	16800	16800	20800	
T38x20.5x13.8					9910(A06)					
T38x22x14						10700				
T40x5.3x1.0	1030									
T40x25x20	4600				11000(A06)					
T42x26x12.8	3010				6030				14460	
T47x27x15						11350				
T48x30x15	3465				6930	9700	13860	13860		
T49.1x33.8x15.9	2935				5870		11750	11750	14100	
T50x30x20						12250				
T55.5x32.6x18					9365	13100	18730	18730		
T58.3x40.8x17.6		4100 (P46)								
T63x38x25					12500	17700	24770	24770		
T78x50.5x16	3430				6850	9590				
T80x40x15	5200									
T85x62x20					6260					
T85.7x55.5x17.2					7500					

Remark:

1. AL Value Testing Condition : 10kHz, 50mV, 1Ts. If testing condition is different from ACME's, please specify upon request & ordering.
2. Coating Material
 - (1) Toroid Size T8 and Below:clear parylene coating, breakdown voltage:1000Vdc, coating thickness : 0.05mm max.
 - (2) Toroid Size T9 and Above:green epoxy coating, breakdown voltage:1500Vdc, coating thickness : 0.6mm max.

Type : RH Cores

Ordering Code:

Shape:

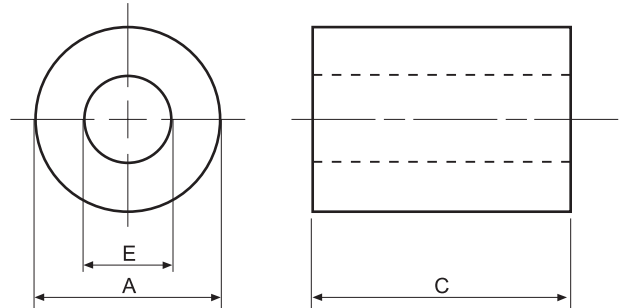
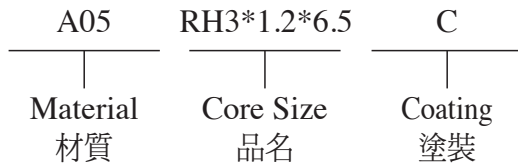

C : Epoxy Coating of Halogen-Free UC : Epoxy Coating of UL & Halogen
 HP : Parylene Coating of Halogen-Free P : Parylene Coating of Halogen

■ DIMENSIONS AND EFFECTIVE PARAMETERS

CORES	DIMENSIONS (mm)			EFFECTIVE PARAMETERS				
	PARYLENE COATING DIMENSIONS (mm)			C _i (mm ⁻¹)	Le(mm)	Ae(mm ²)	Ve(mm ³)	Wt(g/set)
	A	E	C					
RH3x1.2x3.5	3.00 ± 0.15	1.20 ± 0.15	3.50 ± 0.20	2.09	6.60	3.15	20.78	0.100
	3.00 ± 0.15	1.20 ± 0.15	3.50 ± 0.20					
RH3x1.2x6.5	3.00 ± 0.15	1.20 ± 0.15	6.50 ± 0.20	1.13	6.60	5.85	38.61	0.185
	3.00 ± 0.15	1.20 ± 0.15	6.50 ± 0.20					
RH3x1.2x7	3.00 ± 0.15	1.20 ± 0.15	7.00 ± 0.20	1.05	41.58	6.30	6.60	0.199
	3.00 ± 0.15	1.20 ± 0.15	7.00 ± 0.20					
RH6x3x25	6.00 ± 0.25	3.00 ± 0.25	25.00 ± 0.25	0.38	14.13	37.50	530.14	2.51
	6.00 ± 0.25	3.00 ± 0.25	25.00 ± 0.25					
RH9.5x4.8x9.5*	9.50 ± 0.25	4.80 ± 0.30	9.50 ± 0.30	0.97	20.80	21.48	446.78	2.43
	10.35max*	3.90min*	10.40max*					
RH9.75x6.7x15*	9.75 ± 0.30	6.70 ± 0.30	15.00 ± 0.30	1.13	25.84	22.88	591.08	2.86
	10.65max*	5.80min*	15.90max*					
RH9.75x6.7x19.6*	9.75 ± 0.30	6.70 ± 0.30	19.60 ± 0.30	0.86	25.82	29.89	771.95	3.65
	10.65max*	5.80min*	20.50max*					
RH10x4.5x20*	10.00 ± 0.30	4.50 ± 0.30	20.00 ± 0.50	0.39	20.53	52.18	1071.26	5.92
	10.90max*	3.60min*	21.10max*					

Remark:

* Epoxy coating dimensions.



■ ELECTRICAL CHARACTERISTICS

CORES	AL \pm 25% (nH/N ²)				AL \pm 30% (nH/N ²)			
	P4	P5	A05	A07	A10	A102	A121	A151
RH3x1.2x3.5			3000					
RH3x1.2x6.5			5575					
RH3x1.2x7			6000					
RH6x3x25	8000							
RH9.5x4.8x9.5	3300							
RH9.75x6.7x15	2780							
RH9.75x6.7x19.6	3635							
RH10x4.5x20	8000							

Remark:

1. AL Value Testing Condition : 10kHz, 50mV, 1Ts. If testing condition is different from ACME's, please specify upon request & ordering.

2. Coating Material

(1) Toroid Size T8 and Below:clear parylene coating, breakdown voltage:1000Vdc, coating thickness : 0.05mm max.

(2) Toroid Size T9 and Above:green epoxy coating, breakdown voltage:1500Vdc, coating thickness : 0.6mm max.

Type : R Cores

Ordering Code:

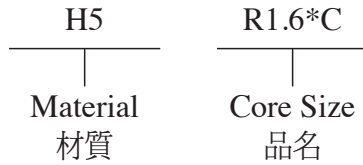

C : Highly

Shape:

Type:1

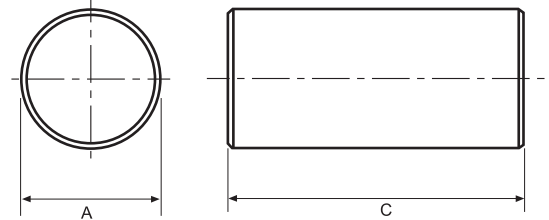

Type:2

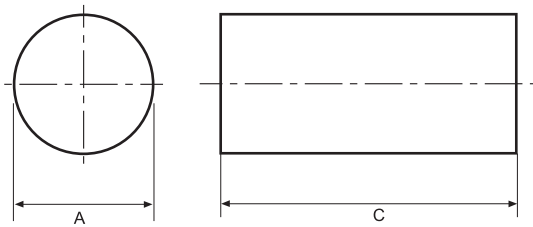

Type:3

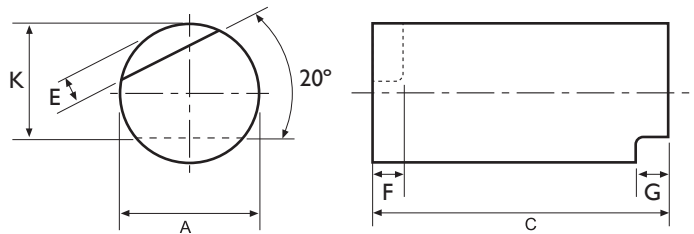

■ DIMENSIONS

CORES	DIMENSIONS (mm)			Type
	A	C	θ	
R1.6xC	1.60 ± 0.10	7.00 - 16.00	-	2
R1.8xC	1.80 ^{+0.00} / _{-0.05}	7.00 - 18.00	-	1
R2.0xC	2.00 ± 0.10	7.00 - 18.00	-	1
R2.4xC	2.40 ^{+0.00} / _{-0.20}	7.00 - 20.00	-	1
R2.5xC	2.50 ^{+0.00} / _{-0.05}	7.00 - 20.00	-	2
R3.0xC	3.00 ± 0.15	7.00 - 28.00	-	1
R3.5xC	3.50 ± 0.15	7.00 - 28.00	-	1
R4.0xC	4.00 ^{+0.00} / _{-0.10}	15.00 - 25.00	45° (Ref)	3
R4.0xC	4.00 ± 0.15	7.00 - 30.00	-	1
R4.6xC	4.60 ^{+0.00} / _{-0.25}	7.00 - 30.00	-	1
R5.0xC	5.00 ^{+0.00} / _{-0.10}	15.00 - 30.00	60° (Ref)	3
R5.0xC	5.00 ± 0.20	7.00 - 35.00	-	1
R5.2xC	5.25 ^{+0.00} / _{-0.10}	15.00 - 25.00	20° (Ref)	3
R5.5xC	5.50 ^{+0.00} / _{-0.10}	15.00 - 25.00	90° (Ref)	3
R6.0xC	6.00 ^{+0.00} / _{-0.10}	15.00 - 29.00	30° (Ref)	3
R6.0xC	6.00 ^{+0.00} / _{-0.30}	7.00 - 38.00	-	1
R6.5xC	6.50 ^{+0.00} / _{-0.30}	7.00 - 38.00	-	1
R7.0xC	7.00 ± 0.20	7.00 - 40.00	-	1
R7.0xC	7.00 ^{+0.00} / _{-0.20}	15.00 - 29.00	50° (Ref)	3
R8.0xC	8.00 ± 0.20	7.00 - 40.00	-	1
R8.0xC	8.00 ^{+0.00} / _{-0.40}	7.00 - 40.00	-	1
R8.0xC	8.00 ^{+0.00} / _{-0.20}	15.00 - 29.00	55° (Ref)	3
R9.5xC	9.50 ± 0.20	7.00 - 40.00	-	1
R10xC	10.00 ± 0.20	7.00 - 40.00	-	1
R10xC	10.00 ^{+0.00} / _{-0.40}	7.00 - 40.00	-	1
R12.0xC	12.00 ± 0.20	7.00 - 40.00	-	1

Type : DR Cores

Ordering Code:

Shape:

Type:1

B45 DR1.95*1.4*0.85*0.9R

Material Core Size
材質 品名

R : Slot, 出線槽

W : Hole, 接PIN的孔; (2W: 2 holes)

D3 :Shape with different flange size, 上下擺外徑不同

SV : Plating, 電鍍

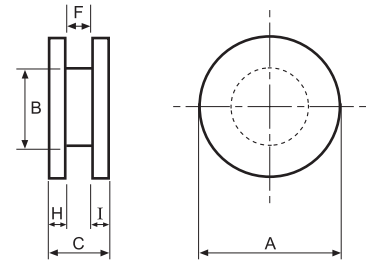

Type:2

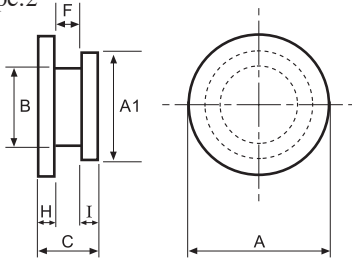

Type:3

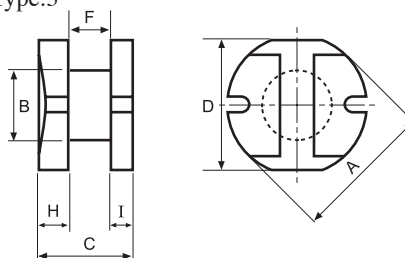

Type:4

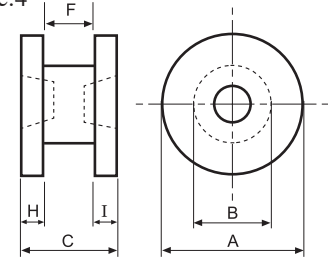

■ DIMENSIONS

CORES	DIMENSIONS (mm)								Wt(g/set)	Type
	A	A1	B	C	D	F	H	I		
DR1.67x1.6x0.93x0.9WW	1.67 ± 0.07	-	0.87 ± 0.10	1.60 ± 0.10	-	0.90 ± 0.07	0.35 ± 0.07	0.35 ± 0.07	0.01	4
DR1.95x1.4x0.85x0.9R	1.95 ± 0.07	-	0.85 ± 0.10	1.40 ± 0.05	-	0.90 ± 0.10	0.25 ± 0.10	0.25 ± 0.10	0.01	5
DR2x1.1x1x0.56	2.00 ± 0.05	-	1.00 ± 0.05	1.10 ± 0.05	-	0.56 ± 0.05	0.27 ± 0.05	-	0.01	1
DR2.15x0.9x0.8x0.4D3	2.15 ± 0.10	2.05 ± 0.10	0.90 ± 0.05	0.90 ± 0.10	-	0.40 ± 0.10	0.25 (Ref)	0.25 (Ref)	0.01	2
DR2.3x0.9x0.8x0.4D3	2.30 ± 0.10	2.05 ± 0.10	0.80 ± 0.05	0.90 ± 0.05	-	0.40 ± 0.05	0.25 (Ref)	0.25 (Ref)	0.01	2
DR2.3x1x1.1x0.58	2.30 ± 0.07	-	1.10 ± 0.05	1.00 ± 0.05	-	0.58 ± 0.05	0.21 ± 0.05	0.21 ± 0.05	0.01	1
DR2.35x1.1x1x0.5R	2.35 ± 0.07	-	1.10 ± 0.05	1.00 ± 0.06	-	0.50 ± 0.01	0.25 (Ref)	0.25 (Ref)	0.01	5
DR2.45x2.25x1.3x1.35WW	2.45 ± 0.05	-	1.30 ± 0.05	2.25 ± 0.10	-	1.35 ^{+0.10} / _{-0.00}	0.45 ± 0.07	0.45 ± 0.07	0.03	4
DR2.5x2.5x1.1x1.34WW	2.50 ± 0.10	-	1.10 ± 0.07	2.50 ± 0.10	-	1.34 ± 0.07	0.58 (Ref)	0.58 (Ref)	-	6
DR2.8x1.05x0.85x0.5	2.80 ± 0.10	2.00 ± 0.10	0.85 ± 0.10	1.05 ± 0.10	-	0.50 ± 0.10	0.28 ± 0.10	0.28 ± 0.10	0.02	1
DR2.8x1.35x1.2x0.75D3	2.80 ± 0.10	2.00 ± 0.10	1.20 ± 0.10	1.35 ± 0.10	-	0.75 ± 0.10	0.30 ± 0.10	0.30 ± 0.10	0.02	2
DR2.85x0.65x1.3x0.25	2.85 ± 0.05	2.85 ± 0.05	1.30 ± 0.05	0.65 ± 0.05	-	0.25 ± 0.05	0.20 ± 0.05	0.20 ± 0.05	0.02	10
DR2.9x1x1.5x0.6R	2.90 ± 0.10	-	1.50 ± 0.10	1.00 ± 0.05	-	0.60 ± 0.10	0.20 ± 0.10	0.20 ± 0.10	0.02	5
DR3.2x0.65x1.5x0.25	3.20 ± 0.05	3.20 ± 0.05	1.50 ± 0.05	0.65 ± 0.05	-	0.25 ± 0.05	0.20 ± 0.05	0.20 ± 0.05	0.02	10
DR3.3x1.1x1.1x0.45	3.30 ± 0.08	-	1.10 ± 0.08	1.10 ± 0.08	-	0.45 ± 0.05	0.33 ± 0.05	0.33 ± 0.05	0.03	1
DR3.5x1.5x1.35x0.7D3	3.50 ± 0.10	2.60 ± 0.10	1.35 ± 0.10	1.50 ± 0.10	-	0.70 ± 0.10	0.40 ± 0.10	0.40 ± 0.10	0.04	2
DR3.5x2.2x1.85x1.2	3.50 ± 0.15	-	1.85 ± 0.15	2.20 ± 0.15	-	1.20 ± 0.15	0.50 ± 0.15	-	0.06	1
DR3.5x4.5x1.9x3WW	3.50 ± 0.15	-	1.90 ± 0.10	4.50 ± 0.20	-	3.00 ± 0.15	0.75 (Ref)	0.75 (Ref)	-	7
DR3.8x1.75x2x1.05	3.80 ± 0.10	-	1.55 ± 0.10	1.75 ± 0.10	-	0.95 ± 0.10	0.40 ± 0.10	0.40 ± 0.10	0.06	5
DR3.8x1.75x2x1.05	3.80 ± 0.05	-	2.00 ± 0.05	1.75 ± 0.05	-	1.05 ± 0.05	0.35 ± 0.05	0.35 ± 0.05	0.06	1
DR3.9x0.85x2x0.35	3.90 ± 0.05	3.90 ± 0.05	2.00 ± 0.05	0.85 ± 0.05	-	0.35 ± 0.05	0.25 ± 0.05	0.25 ± 0.05	0.02	10
DR4.0x3.0x1.7x1.2WW	4.00 ± 0.10	-	1.70 ± 0.10	3.00 ± 0.15	-	1.20 ± 0.10	0.90 (Ref)	0.90 (Ref)	-	6
DR4.0x4.5x2.0x2.3	4.00 ± 0.20	-	2.00 ± 0.20	4.50 ± 0.20	-	2.30 ± 0.15	1.10 (Ref)	1.10 (Ref)	-	1
DR4.2x2.5x1.65x1.6	4.20 ± 0.05	-	1.65 ± 0.05	2.50 ± 0.05	-	1.60 ± 0.05	0.45 ± 0.05	0.45 ± 0.05	0.08	1
DR4.25x2.3x2.45x1.3D3	4.25 ± 0.05	3.80 ± 0.05	2.45 ± 0.05	2.30 ± 0.05	-	1.35 ± 0.05	0.30 ± 0.05	0.65 ± 0.05	0.07	11
DR4.4x0.77x2.1x0.27	4.40 ± 0.05	4.40 ± 0.05	2.10 ± 0.05	0.77 ± 0.05	-	0.27 ± 0.05	0.25 ± 0.05	0.25 ± 0.05	0.05	10
DR4.5x3.2x1.7x1.5R	4.50 ± 0.20	-	1.70 ± 0.15	3.20 ± 0.20	4.10 ± 0.15	1.50 ± 0.15	0.65 ± 0.15	-	0.12	3
DR4.5x3.2x2.45x2.2R	4.50 ^{+0.05} / _{-0.10}	-	2.20 ± 0.10	3.20 ± 0.10	-	2.20 ± 0.10	0.50 ± 0.10	0.50 ± 0.10	0.12	5
DR4.6x1.6x1.6x0.65D3	4.60 ± 0.10	3.32 ± 0.10	1.60 ± 0.10	1.60 ± 0.10	-	0.65 ± 0.10	0.50 ^{+0.10} / _{-0.05}	0.45 ^{+0.10} / _{-0.05}	0.07	2
DR4.7x2.2x1.6x1.3D3	4.70 ^{+0.00} / _{-0.15}	3.30 ± 0.08	1.60 ± 0.08	2.20 ± 0.08	-	1.30 ± 0.08	0.45 ± 0.08	0.45 ± 0.08	0.08	2
DR4.9x1.8x1.7x1	4.90 ± 0.05	4.90 ± 0.05	1.70 ± 0.05	1.80 ± 0.05	-	1.00 ± 0.05	0.40 ± 0.05	0.40 ± 0.05	0.12	10

Type:5

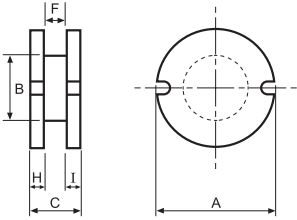

Type:6

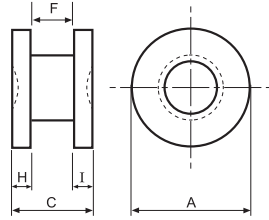

Type:7

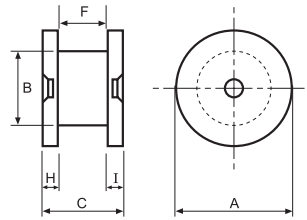

Type:8

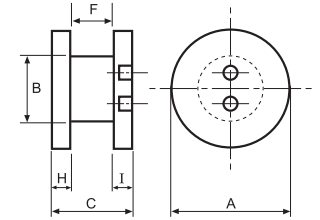

Type:9

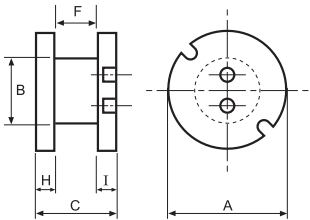

Type:10

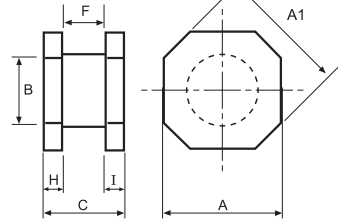

Type:11

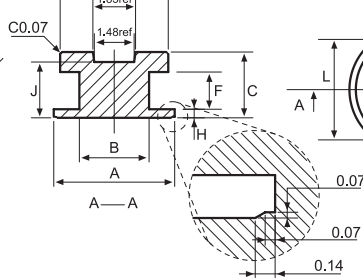

Type:12

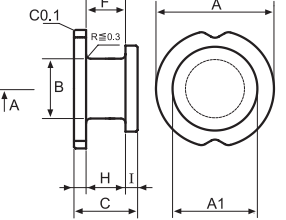

■ DIMENSIONS

CORES	DIMENSIONS (mm)								Wt(g/set)	Type
	A	A1	B	C	D	F	H	I		
DR5.0x1.7x2x1.05D3	5.00 ^{+0.00} / _{-0.20}	3.60 ± 0.10	2.00 ± 0.10	1.65 ± 0.05	-	1.05 ± 0.10	0.30 ± 0.05	0.30 ± 0.05	0.07	2
DR5.0x7.0x2.2x0.4	5.00 ± 0.20	-	2.20 ± 0.15	7.00 ± 0.30	-	4.00 ± 0.25	1.50 (Ref)	1.50 (Ref)	-	1
DR5.0x8.0x2.5x4.2WW	5.00 ± 0.20	-	2.50 ± 0.15	8.00 ± 0.30	-	4.20 ± 0.20	1.90 (Ref)	1.90 (Ref)	-	7
DR5.7x1.7x1.8x0.8D3	5.70 ^{+0.00} / _{-0.15}	4.10 ± 0.07	1.80 ± 0.07	1.70 ± 0.07	-	0.80 ± 0.07	0.45 ± 0.07	0.45 ± 0.07	0.10	2
DR5.8x4.1x3.7x2.9D3	5.80 ± 0.10	4.60 ± 0.10	3.70 ± 0.10	4.10 ± 0.10	-	2.90 ± 0.10	0.60 ± 0.10	0.60 ± 0.10	0.30	2
DR5.8x4.5x2.5x2.4R	5.80 ± 0.15	-	2.50 ± 0.15	4.50 ± 0.20	5.20 ± 0.15	2.40 ± 0.15	-	0.80 ± 0.15	0.27	3
DR6.0x1.3x3.8x0.6	6.00 ± 0.10	-	3.80 ± 0.10	1.30 ± 0.10	-	0.60 ± 0.10	0.35 ± 0.10	0.35 ± 0.10	0.13	1
DR6.0x8.0x3.0x3.0WW	6.00 ± 0.20	-	3.00 ± 0.20	8.00 ± 0.30	-	3.00 ± 0.20	2.50 (Ref)	2.50 (Ref)	-	7
DR6.0x8.0x2.5x4.2-2W	6.00 ± 0.20	-	2.50 ± 0.20	8.00 ± 0.30	-	4.20 ± 0.20	1.90 (Ref)	1.90 (Ref)	-	8
DR6.0x8.0x2.5x4.4R	6.00 ± 0.15	-	2.50 ± 0.15	8.00 ± 0.25	-	4.40 ± 0.15	1.80 (Ref)	1.80 (Ref)	-	5
DR6.4x1.4x2.18x0.6D3	6.40 ± 0.10	5.10 ± 0.10	2.18 ± 0.05	1.40 ± 0.05	-	0.60 ± 0.05	0.40 ± 0.05	0.40 ± 0.05	0.14	2
DR6.5x9.6x3.0x4.8R2W	6.50 ± 0.20	-	3.00 ± 0.15	9.60 ± 0.30	-	4.80 ± 0.20	2.40 (Ref)	2.40 (Ref)	-	9
DR7x4.2x2.55x2	7.00 ± 0.10	7.00 ± 0.10	2.55 ± 0.10	4.20 ± 0.10	-	2.00 ± 0.08	1.00 ± 0.08	1.00 ± 0.08	0.61	10
DR7.5x9.0x3.0x2.8WW	7.50 ± 0.20	-	3.00 ± 0.20	9.00 ± 0.30	-	2.80 ± 0.10	3.10 (Ref)	3.10 (Ref)	-	7
DR7.5x9.0x3.2x5.0R2W	7.50 ± 0.20	-	3.20 ± 0.20	9.00 ± 0.30	-	5.00 ± 0.20	2.00 (Ref)	2.00 (Ref)	-	9
DR7.6x3.7x3.2x2.2	7.60 ± 0.15	-	3.20 ± 0.15	3.70 ± 0.10	-	2.20 ± 0.10	0.75 ± 0.10	0.75 ± 0.10	0.49	1
DR7.8x5x3x2.6R	7.80 ± 0.20	-	3.00 ± 0.15	5.00 ± 0.20	7.00 ± 0.20	2.60 ± 0.15	1.50 ± 0.15	0.90 ± 0.10	0.68	3
DR8.0x4.1x4x2.5D3	8.00 ± 0.15	5.78 ± 0.15	4.00 ± 0.15	4.10 ± 0.10	-	2.50 ± 0.10	0.80 ± 0.10	0.80 ± 0.10	0.49	2
DR8.0x4.2x4x2.6RD3	8.00 ± 0.15	5.75 ± 0.15	4.00 ± 0.15	4.20 ± 0.10	-	2.60 ± 0.10	0.80 ± 0.10	0.80 ± 0.10	0.49	12
DR8.0x10.0x3.0x5.0-2W	8.00 ± 0.20	-	3.00 ± 0.20	10.00 ± 0.40	-	5.00 ± 0.20	2.50 (Ref)	2.50 (Ref)	-	8
DR8.0x10.0x4.0x6.0R2W	8.00 ± 0.20	-	4.00 ± 0.20	10.00 ± 0.30	-	6.00 ± 0.20	2.00 (Ref)	2.00 (Ref)	-	9
DR8.38x4x3x2	8.38 ± 0.15	-	3.00 ± 0.15	4.00 ± 0.20	-	2.00 ± 0.15	1.00 (Ref)	-	0.61	1
DR8.7x2.7x3.0x1.5D3	8.70 ± 0.10	5.80 ± 0.10	3.00 ± 0.10	2.70 ± 0.10	-	1.50 ± 0.10	0.60 ± 0.10	0.60 ± 0.10	0.40	2
DR9.6x3.65x5.2x1.8D3	9.60 ± 0.15	7.50 ± 0.15	5.20 ± 0.15	3.65 ± 0.15	-	1.80 ± 0.15	0.93 ± 0.10	0.93 ± 0.10	0.75	2
DR9.8x3.65x4.8x1.95D3	9.80 ± 0.15	7.60 ± 0.15	4.80 ± 0.15	3.65 ± 0.15	-	1.95 ± 0.10	0.85 (Ref)	0.85 (Ref)	0.67	2
DR9.8x5.2x5.5x3.2R	9.80 ± 0.15	-	5.50 ± 0.15	5.20 ± 0.15	-	3.20 ± 0.15	1.00 ± 0.10	1.00 ± 0.10	1.16	5
DR10x5.4x4x2.6R	10.00 ± 0.20	-	4.00 ± 0.25	5.40 ± 0.20	9.00 ± 0.20	2.60 ± 0.15	1.60 ± 0.15	1.20 ± 0.15	1.31	3
DR10x16x6.0x10WW	10.00 ± 0.30	-	6.00 ± 0.20	16.00 ± 0.50	-	10.00 ± 0.30	3.00 (Ref)	3.00 (Ref)	-	7
DR10x16x6.0x10A2W	10.00 ± 0.30	-	6.00 ± 0.30	16.00 ± 0.40	-	10.00 ± 0.30	3.00 (Ref)	3.00 (Ref)	-	8

Type : SRI/RI Cores

Ordering Code:



Shape:

Type:1

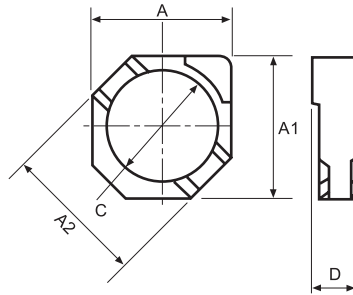

Type:2

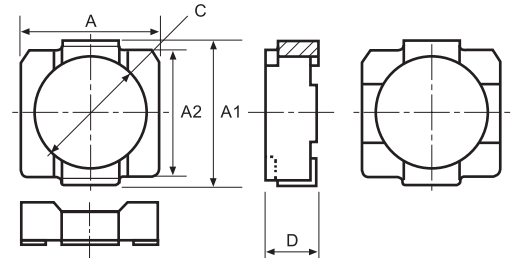

Type:3

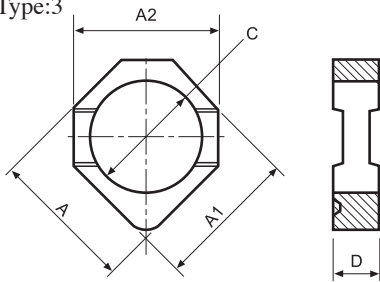

Type:4

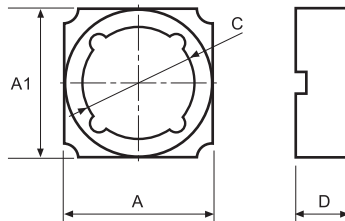

Type:5

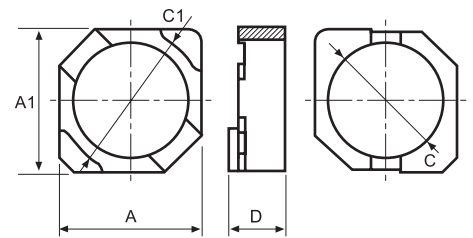

Type:6

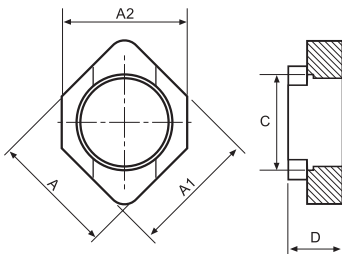

Type:7

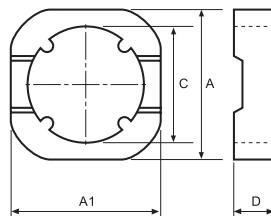

Type:8

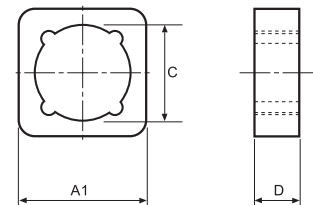

■ DIMENSIONS

CORES	DIMENSIONS (mm)					Wt(g/set)	Type
	A	A1	A2	C	D		
SRI2.95x2.15x1.4	2.95 ± 0.10	2.95 ± 0.10	—	2.15 ± 0.10	1.40 ± 0.05	0.03	6
SRI3x2.4x0.9	3.00 ± 0.10	3.00 ± 0.10	3.00 ± 0.10	2.40 ± 0.10	0.90 ± 0.10	0.01	3
SRI3x2.4x1.05	3.00 ± 0.08	—	—	2.40 ± 0.08	1.05 ± 0.10	0.02	1
SRI3x2.4x1.2	3.00 ± 0.10	—	—	2.40 ± 0.10	1.20 ± 0.10	—	1
SRI3x2.5x1.6	3.00 ± 0.10	—	—	2.50 ± 0.10	1.60 ± 0.10	0.02	3
SRI3.2x0.98x2.55	3.20 ± 0.10	3.20 ± 0.10	—	2.55 ± 0.03	0.98 ± 0.05	0.02	6
SRI3.5x3.1x1	3.50 ± 0.10	3.50 ± 0.10	—	3.10 ± 0.10	1.00 ± 0.05	0.02	6
SRI3.8x3.1x1.35	3.80 ± 0.10	—	—	3.10 ± 0.10	1.35 ± 0.10	0.02	1
SRI4.7x3.9x1.45	4.70 ± 0.10	4.70 ± 0.10	—	3.90 ± 0.10	1.45 ± 0.10	0.05	5
SRI4.8x3.9x1.75	4.80 ± 0.10	5.00 ± 0.10	4.40 ± 0.10	3.90 ± 0.08	1.75 ± 0.08	0.01	2
SRI4.8x4.1x1.7	4.80 ± 0.15	4.80 ± 0.15	5.15 ± 0.15	4.10 ± 0.10	1.70 ± 0.10	0.06	11
SRI5.1x4x1.7	5.10 ± 0.10	5.10 ± 0.10	—	4.00 ± 0.10	1.70 ± 0.05	0.08	4
SRI5.1x4.3x1.1	5.10 ± 0.10	5.10 ± 0.10	—	4.30 ± 0.10	1.10 ± 0.10	0.05	10
SRI5.7x4.7x1.45	5.70 ± 0.10	5.70 ± 0.10	6.00 ± 0.10	4.70 ^{+0.15} / _{-0.00}	1.45 ± 0.10	0.08	5
SRI5.9x4.4x2.6	5.90 ± 0.10	5.70 ± 0.10	—	4.40 ± 0.10	2.60 ± 0.10	0.17	16
SRI5.95x4.75x3	6.00 ^{+0.15} / _{-0.10}	5.60 ± 0.15	—	4.80 ^{+0.10} / _{-0.05}	3.00 ± 0.07	0.19	7

Type:9

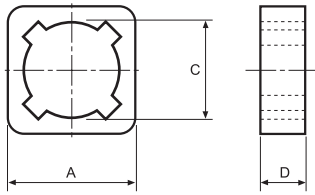

Type:10

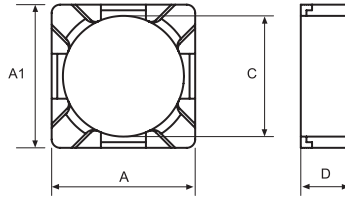

Type:11

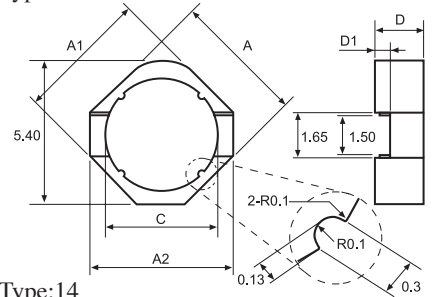

Type:12

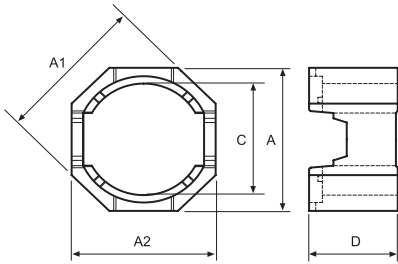

Type:13

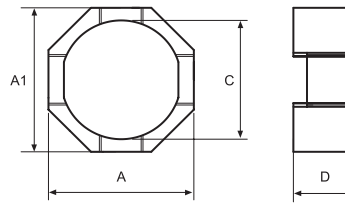

Type:14

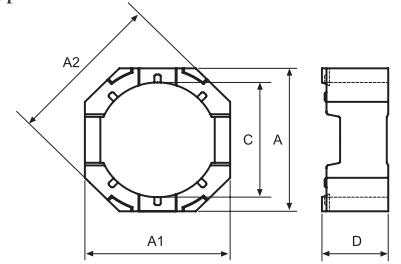

Type:15

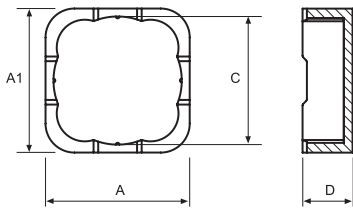

Type:16

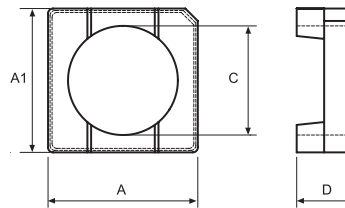

Type:17

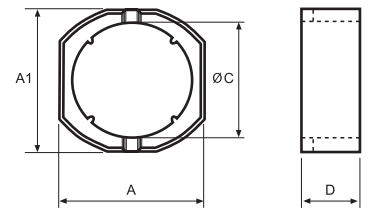

Type:18

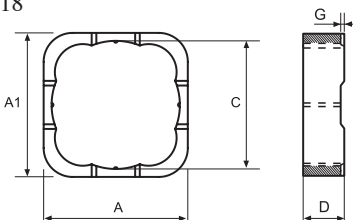

Type:19

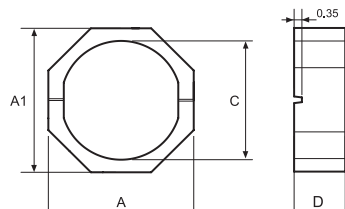

Type:20

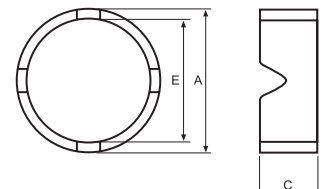

■ DIMENSIONS

CORES	DIMENSIONS (mm)						Wt(g/set)	Type
	A	A1	A2	C	D	E		
SRI6.7x5.5x3.5	6.70 ± 0.10	6.70 ± 0.10		5.50 ^{+0.15} / _{-0.00}	3.50 ± 0.10		0.38	5
SRI6.8x5.3x4	6.80 ± 0.10	7.00 ± 0.10	6.50 ± 0.10	5.30 ± 0.10	4.00 ± 0.10	–	0.28	12
SRI7.3x5.6x3.5	7.30 ± 0.15	–	–	5.60 ± 0.20	3.50 ± 0.15	–	–	9
SRI7.3x5.9x1.5	7.30 ± 0.10	7.30 ± 0.10		5.90 ^{+0.15} / _{-0.00}	1.50 ± 0.07		0.19	17
SRI7.3x5.9x2.3	7.30 ± 0.10	7.30 ± 0.10		5.90 ± 0.15	2.30 ± 0.10		0.31	19
SRI8x6.6x3.4	8.00 ± 0.15	8.00 ± 0.15	–	6.60 ± 0.10	3.40 ± 0.10	–	0.29	13
SRI8.1x6.5x3.65	8.10 ± 0.15	8.70 ± 0.15	8.00 ± 0.15	6.50 ± 0.10	3.65 ± 0.10	–	0.39	14
SRI10x8.2x4.3	10.00 ± 0.20	10.00 ± 0.20	–	8.20 ± 0.15	4.30 ± 0.15	–	0.67	5
SRI12x10.6x6.6	12.00 ± 0.20	–	–	10.60 ± 0.20	6.60 ± 0.20	–	–	8
SRI12x10.8x5	12.00 ^{+0.40} / _{-0.00}	–	–	10.85 ^{+0.20} / _{-0.10}	5.00 ^{+0.10} / _{-0.20}	–	–	8
SRI12.1x10.6x3.6	12.10 ± 0.15	–	–	10.60 ± 0.15	3.60 ± 0.15	–	–	8
SRI14.8x12.2x6.8	14.80 ± 0.15	14.80 ± 0.15		12.20 ± 0.20	6.80 ± 0.10		4.17	5
SRI14.8x12.3x9.9	14.95 ± 0.15	14.95 ± 0.15		12.30 ± 0.20	9.90 ± 0.15		5.04	18
SRI19.9x17.7x6.9	19.90 ± 0.20	19.90 ± 0.20	–	17.70 ± 0.20	6.90 ± 0.15	–	5.43	15
RI3.3x2.58x1.9	3.30 ± 0.10	–		1.90 ± 0.10	–	2.58 ± 0.05	0.03	20
RI12.2x10.6x4.8	12.20 ± 0.20	–	–	4.80 ± 0.15	–	10.60 ± 0.15	0.66	20

Type : SDR Cores

Ordering Code:

B45	SDR3*0.93*1.2*0.27D3SV
Material	Core Size
材質	品名

D3 :Shape with different flange size, 上下擺外徑不同

SV : Plating, 電鍍

Shape:

Type:1

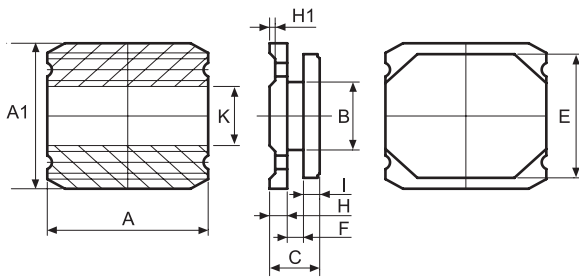

Type:2

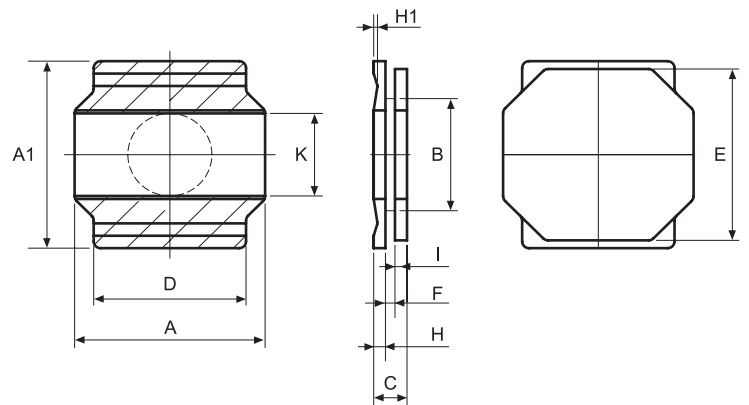

■ DIMENSIONS

CORES	DIMENSIONS (mm)						
	A	A1	B	C	D	D1	E
SDR3x0.93x1.2x0.27D3SV	3.00 ± 0.05	3.00 ± 0.05	1.20 ± 0.05	0.93 ± 0.05	—	—	2.55 ± 0.05
SDR3Ax0.9x1.4x0.3D3SV	3.00 ± 0.05	3.00 ± 0.05	1.40 ± 0.07	0.90 ± 0.05	2.50 ± 0.07	—	2.50 ± 0.07
SDR4x0.93x2.2x0.27D3SV	4.00 ± 0.05	4.00 ± 0.05	2.20 ± 0.05	0.93 ± 0.05	—	—	3.60 ± 0.05
SDR4Ax0.9x2x0.25D3SV	4.00 ± 0.07	4.00 ± 0.07	2.00 ± 0.07	0.90 ± 0.05	3.50 ± 0.07	—	3.50 ± 0.05
SDR6Ax0.9x3.8x0.25D3SV	6.00 ± 0.10	6.00 ± 0.10	3.80 ± 0.10	0.90 ± 0.05	4.80 ± 0.10	—	5.50 ± 0.10
SDR6Ax1.05x3.4x0.3D3SV	6.00 ± 0.10	6.00 ± 0.10	3.40 ± 0.10	1.05 ± 0.05	4.80 ± 0.10	—	5.50 ± 0.10
SDR6Dx0.9x4.0x0.25D3SV	5.95 ± 0.10	5.95 ± 0.10	4.00 ± 0.10	0.90 ± 0.05	5.20 ± 0.10	5.00 ± 0.10	5.55 ± 0.10
SDR6Dx1.08x3.4x0.32D3SV	5.95 ± 0.10	5.95 ± 0.10	3.40 ± 0.10	1.08 ± 0.05	5.20 ± 0.10	5.00 ± 0.10	5.55 ± 0.10
SDR6Dx1.35x3.3x0.55D3SV	5.95 ± 0.10	5.95 ± 0.10	3.30 ± 0.10	1.35 ± 0.05	5.20 ± 0.10	5.00 ± 0.10	5.55 ± 0.10
SDR6Ex1.4x3.3x0.55D3SV	5.95 ± 0.15	5.95 ± 0.15	3.30 ± 0.10	1.40 ± 0.07	5.20 ± 0.10	5.00 ± 0.10	5.55 ± 0.10
SDR8x3.7x3.6x2.0SV	8.00 ^{+0.10} / _{-0.15}	8.00 ^{+0.10} / _{-0.15}	3.60 ± 0.10	3.70 ± 0.10	7.50 ± 0.10	—	6.30 ± 0.15

Type:3

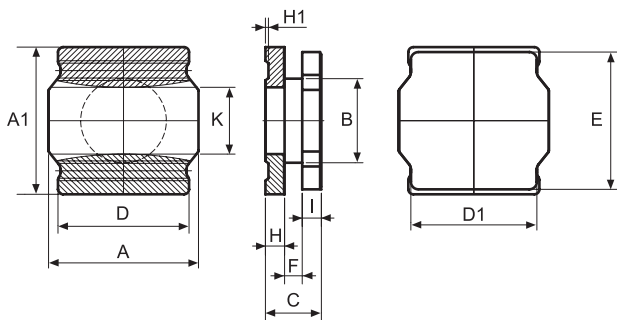

Type:4

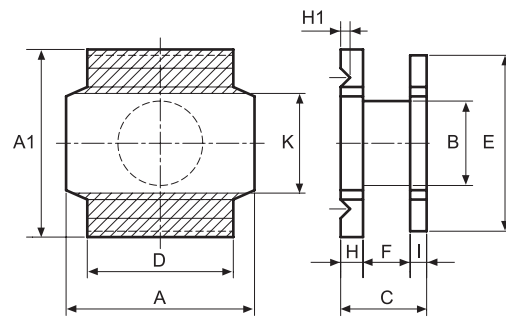

■ DIMENSIONS

CORES	DIMENSIONS (mm)					Wt(g/set)	Type
	F	H	H1	I	K		
SDR3x0.93x1.2x0.27D3SV	0.27 ± 0.05	0.33 ± 0.05	0.10 ± 0.05	0.33 ± 0.05	1.20 ± 0.25	0.05	1
SDR3Ax0.9x1.4x0.3D3SV	0.30 ± 0.05	0.32 ± 0.05	–	0.28 ± 0.05	1.00 ± 0.30	0.05	2
SDR4x0.93x2.2x0.27D3SV	0.27 ± 0.05	0.33 ± 0.05	0.10 ± 0.05	0.33 ± 0.05	1.55 ± 0.25	0.11	1
SDR4Ax0.9x2x0.25D3SV	0.25 ± 0.05	0.35 ± 0.05	–	0.30 ± 0.05	1.40 ± 0.30	0.10	2
SDR6Ax0.9x3.8x0.25D3SV	0.25 ± 0.04	0.35 ± 0.05	–	0.30 ± 0.05	2.65 ± 0.30	0.24	2
SDR6Ax1.05x3.4x0.3D3SV	0.30 $\begin{smallmatrix} +0.03 \\ -0.04 \end{smallmatrix}$	0.38 ± 0.05	–	0.38 ± 0.05	2.65 ± 0.03	0.26	2
SDR6Dx0.9x4.0x0.25D3SV	0.25 ± 0.05	0.35 ± 0.05	0.12 ± 0.05	0.30 ± 0.05	2.55 ± 0.25	0.26	3
SDR6Dx1.08x3.4x0.32D3SV	0.32 ± 0.05	0.38 ± 0.05	0.12 ± 0.05	0.38 ± 0.05	2.70 ± 0.30	0.26	3
SDR6Dx1.35x3.3x0.55D3SV	0.55 ± 0.05	0.45 ± 0.05	0.12 ± 0.05	0.35 ± 0.05	2.70 ± 0.30	0.30	3
SDR6Ex1.4x3.3x0.55D3SV	0.55 ± 0.08	0.45 ± 0.08	0.18 ± 0.05	0.40 ± 0.08	2.55 ± 0.25	0.32	3
SDR8x3.7x3.6x2.0SV	2.00 ± 0.10	0.95 ± 0.10	0.40 ± 0.10	0.70 ± 0.10	4.00 ± 0.30	1.32	4

Type : RID Cores

Shape:

Type:1

Ordering Code:

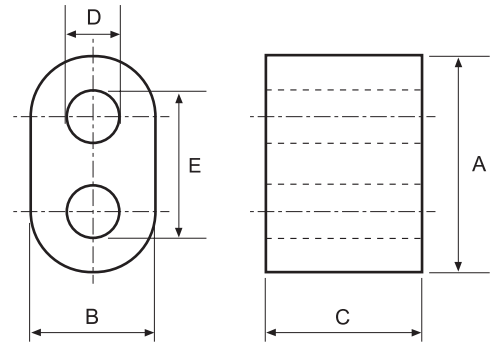
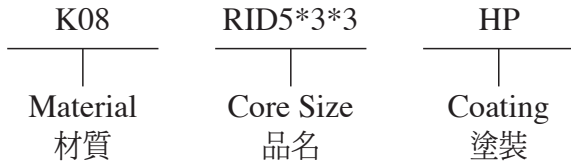

C : Epoxy Coating of Halogen-Free UC : Epoxy Coating of UL & Halogen
 HP : Parylene Coating of Halogen-Free P : Parylene Coating of Halogen

Type:2

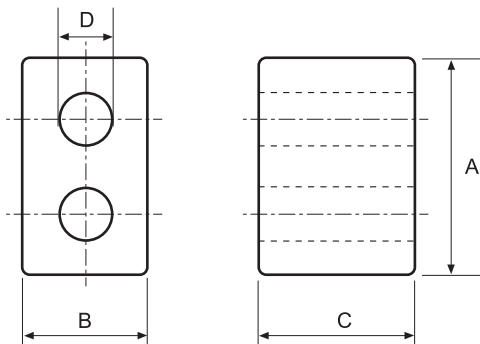

Type:3

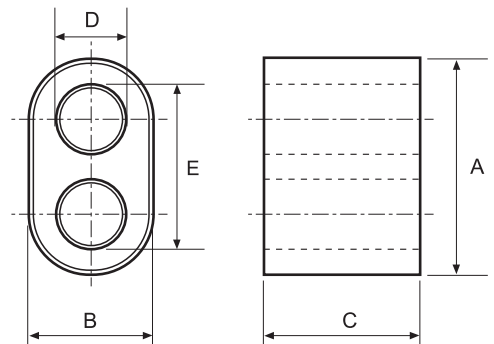

■ DIMENSIONS

CORES	DIMENSIONS (mm)					Type
	A	B	C	D	E	
RID3.6x2.1x2.35	3.60 ± 0.20	2.10 ± 0.20	2.35 ± 0.15	1.00 ± 0.10	2.50 ± 0.20	3
RID5x2x2.8	5.00 ± 0.20	2.00 ± 0.10	2.80 ± 0.20	1.10 ref	—	1
RID5x2.3x3.5	5.00 ± 0.20	2.30 ± 0.15	3.50 ± 0.20	1.20 ± 0.10	—	1
RID5x3x3	5.00 ± 0.30	3.00 ± 0.20	3.00 ± 0.30	1.20 ± 0.20	3.20 ± 0.20	1
RID5.1x2.6x4.2	5.10 ± 0.25	2.60 ± 0.20	4.20 ^{+0.00} / _{-0.40}	1.40 ± 0.10	—	1
RID6x3x5	6.00 ± 0.30	3.00 ± 0.30	5.00 ± 0.30	1.50 ± 0.10	—	1
RID6.9x4.06x6.35	6.90 ± 0.30	4.06 ± 0.25	6.35 ± 0.38	1.50 ± 0.10	—	2
RID7.1x4.0x8.0	7.10 ± 0.20	4.00 ± 0.20	8.00 ± 0.20	2.20 ± 0.10	—	2
RID8.4x4.2x7	8.40 ± 0.25	4.20 ± 0.20	7.00 ± 0.20	1.90 ± 0.10	—	2
RID9.4x5.3x8	9.40 ± 0.35	5.30 ± 0.15	8.00 ± 0.25	2.59 ± 0.10	—	2
RID12x6.8x4	12.00 ± 0.40	6.80 ± 0.30	4.00 ± 0.30	3.80 ± 0.20	—	1
RID13.3x7.5x6.6	13.30 ± 0.50	7.50 ± 0.40	6.60 ± 0.25	3.80 ± 0.25	9.50 ± 0.30	1
RID20x10x15	20.00 ± 0.50	10.00 ± 0.30	15.00 ± 0.50	5.10 ^{+0.30} / _{-0.00}	—	2

Type : R Cores (Multi Aperture)

Ordering Code:

H5	R2H7/5.5
Material	Core Size
材質	品名

R2H:2 Holes

Shape:

Type:1

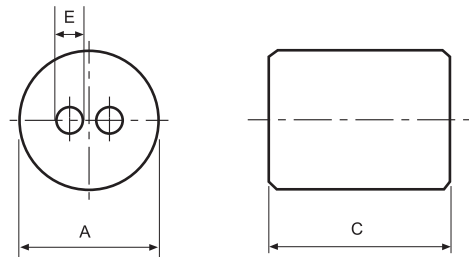

Type:2

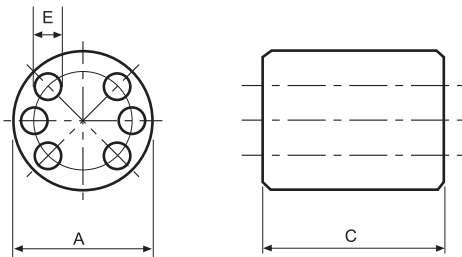

Type:3

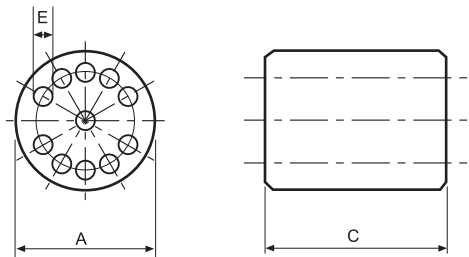

■ DIMENSIONS

CORES	DIMENSIONS (mm)				Type
	A	C	E	L	
R2H7/5.5	7.00 ± 0.20	5.50 ± 0.30	1.80 ± 0.15	3.00 ref	1
R6H6/10	6.00 ± 0.25	10.00 ± 0.25	0.85 $\begin{smallmatrix} +0.20 \\ -0.00 \end{smallmatrix}$	3.50 ref	2
R11H10/10	10.00 ± 0.25	10.00 ± 0.25	0.90 $\begin{smallmatrix} +0.15 \\ -0.00 \end{smallmatrix}$	7.50 ref	3

Type : AR Cores

Shape:

Ordering Code:

H5	AR4.1*4.2*40
Material 材質	Core Size 品名

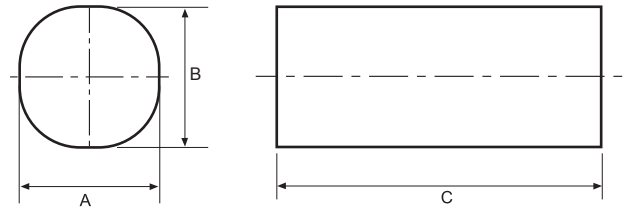

■ DIMENSIONS

CORES	DIMENSIONS (mm)		
	A	B	C
AR4.1x4.2x40	4.10 ± 0.20	4.20 ± 0.20	40.00 ± 1.00
AR4.1x5x40	4.10 ± 0.20	5.00 ± 0.20	40.00 ± 1.00
AR6.15x6.35x50	6.15 ± 0.20	6.35 ± 0.20	50.00 ± 1.00
AR6.15x6.35x95.25	6.15 ± 0.15	6.35 ± 0.25	95.25 ± 1.00
AR9x10x50	9.00 ± 0.30	10.00 ± 0.30	50.00 ± 1.00
AR9x10x60	9.00 ± 0.30	10.00 ± 0.30	60.00 ± 1.00
AR9.2x9.4x50.8	9.20 ± 0.30	9.40 ± 0.30	50.80 ± 1.00
AR9.2x9.4x76.2	9.20 ± 0.30	9.40 ± 0.30	76.20 ^{+0.50} _{-1.00}
AR11x12x60	11.00 ± 0.30	12.00 ± 0.40	60.00 ± 1.60

Type : FC Cores

Ordering Code:

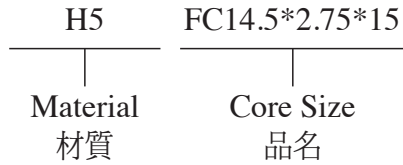

Shape:

Type:1

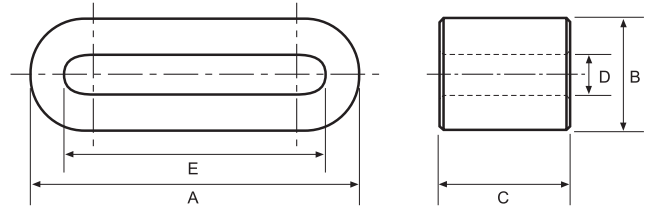

Type:2

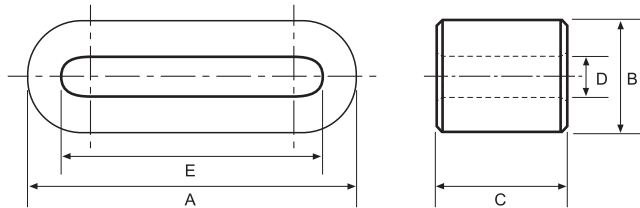

Type:3

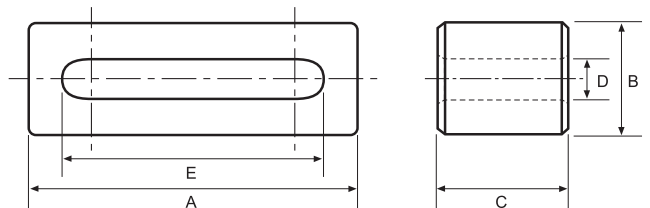

■ DIMENSIONS

CORES	DIMENSIONS (mm)					Type
	A	B	C	D	E	
FC11.5x3x12	11.50 ± 0.25	3.00 ± 0.20	12.00 ± 0.25	0.70 ± 0.15	8.00 ± 0.20	3
FC14.5x2.75x15	14.50 ± 0.50	2.75 ± 0.30	15.00 ± 0.40	0.70 ± 0.30	11.00 ± 0.40	1
FC14.5x2.75x20	14.50 ± 0.50	2.75 ± 0.30	20.00 ± 0.50	0.70 ± 0.30	11.00 ± 0.40	1
FC15.5x3.4x10	15.50 ± 0.38	3.40 ± 0.51	10.00 ± 0.25	1.40 ± 0.51	13.50 ± 0.38	2
FC17x5x6	17.00 ± 0.40	5.00 ± 0.30	6.00 ± 0.50	0.80 ± 0.40	13.00 ± 0.40	1
FC17x5x9	17.00 ± 0.40	5.00 ± 0.30	9.00 ± 0.50	0.80 ± 0.40	13.00 ± 0.40	1
FC22.35x7.75x19.05	22.35 ± 0.51	7.75 ± 0.38	19.05 ± 0.64	1.50 ± 0.15	14.00 ± 0.25	3
FC24.5x5x7	24.50 ± 0.50	5.00 ^{+0.00} / _{-0.60}	7.00 ± 0.30	0.50 ^{+0.50} / _{-0.00}	20.00 ^{+1.00} / _{-0.00}	1
FC31x5x12	31.00 ± 0.70	5.00 ^{+0.00} / _{-0.70}	12.00 ± 0.50	1.00 ± 0.50	27.00 ^{+0.08} / _{-0.60}	2
FC31.4x7.75x21	31.40 ± 0.51	7.75 ± 0.38	21.00 ± 0.64	1.00 ± 0.50	23.00 ± 0.38	3
FC37x8x18.25	37.00 ± 0.80	8.00 ± 0.50	18.25 ± 1.00	1.50 ± 0.40	27.00 ± 0.80	1

Type : I Cores (Plates)

Ordering Code:

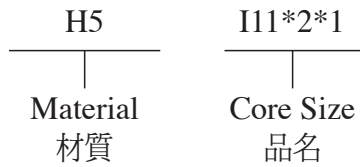

Shape:

Type:1

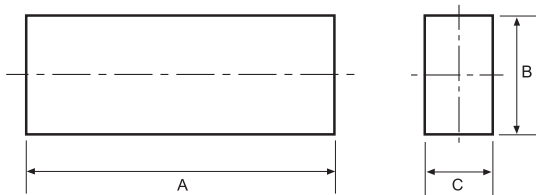

Type:2

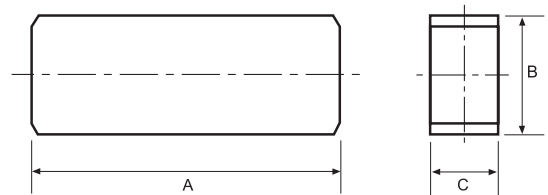

Type:3

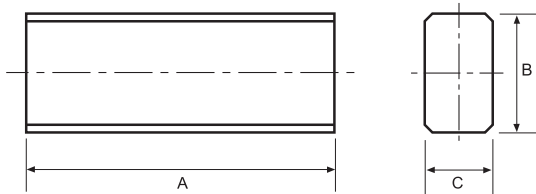

Type:4

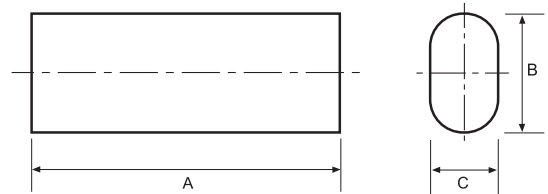

■ DIMENSIONS

CORES	DIMENSIONS (mm)			Type
	A	B	C	
I11x2x1	11.00 ± 0.10	2.00 ± 0.05	1.00 ± 0.05	1
I11x2x1A	11.00 ± 0.10	2.00 ± 0.05	1.00 ± 0.05	2
I11.3x2.1x1.2	11.30 ^{+0.00} _{-0.20}	2.10 ^{+0.00} _{-0.10}	1.20 ^{+0.00} _{-0.10}	1
I11.3x2.2x1.3	11.30 ^{+0.00} _{-0.20}	2.20 ^{+0.00} _{-0.10}	1.30 ^{+0.00} _{-0.10}	3
I29.2x12x5	29.20 ± 0.40	12.00 ± 0.30	5.00 ± 0.30	4
I31.2x9.6x4.6	31.20 ± 0.40	9.60 ± 0.30	4.60 ± 0.30	4
I43.5x16.2x8.8	43.50 ^{+0.10} _{-0.60}	16.20 ± 0.40	8.80 ± 0.30	4
I50x12x3	50.00 ^{+0.20} _{-0.80}	12.00 ± 0.20	3.00 ± 0.10	1

Type : I Cores

Ordering Code:

K081	I53.3*53.3*2.5
Material	Core Size
材質	品名

Shape:

Type:1

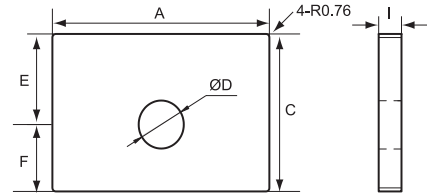

Type:2

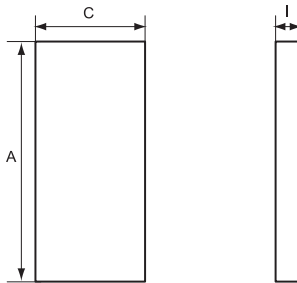

Type:3

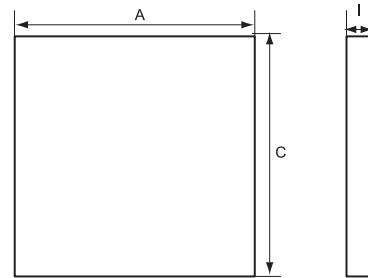

Type:4

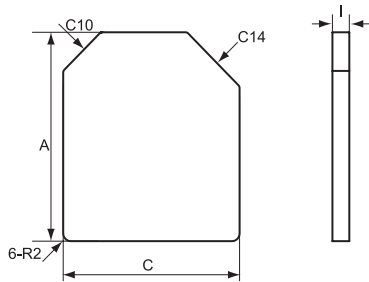

Type:5

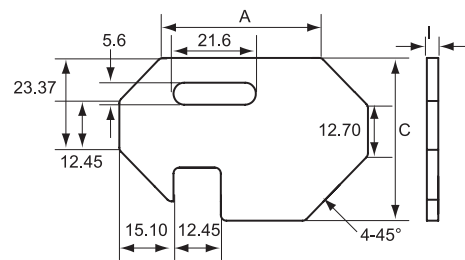

■ DIMENSIONS

CORES	DIMENSIONS (mm)			Wt(g/pc)	Type
	A	C	I		
149.53x33.68x5.2	49.53 ± 0.50	33.68 ± 0.40	5.20 ± 0.15	41.30	1
150x12x3	50.00 ± 0.60	12.00 ± 0.30	3.00 ± 0.15	8.96	2
150x8x2.5	50.00 ± 0.60	8.00 ± 0.25	3.00 ± 0.15	5.10	2
153.3x53.3x2.5	53.30 ± 0.70	53.30 ± 0.70	2.50 ± 0.15	36.50	3
153.5x47x4.5	53.50 ± 0.70	47.00 ± 0.60	4.50 ± 0.15	53.44	4
165.2x41.4x3.0	65.20 ± 0.80	41.40 ± 0.60	3.00 ± 0.15	29.97	5

Type : ET Cores

Ordering Code:

K12	ET25/9.2
Material 材質	Core Size 品名

Shape:

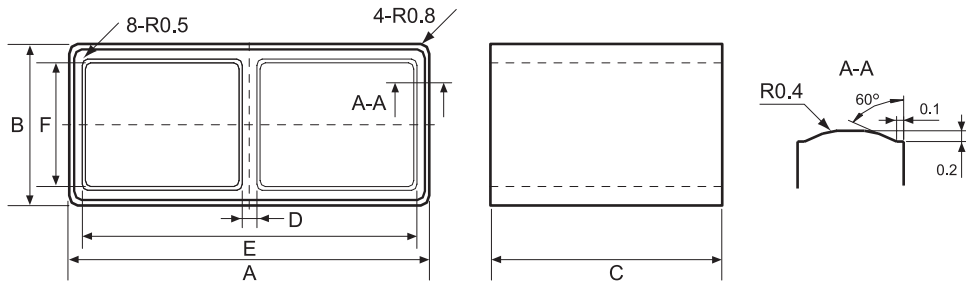

■ DIMENSIONS

CORES	DIMENSIONS (mm)					
	A	B	C	D	E	F
ET25/9.2	25.00 ± 0.40	9.20 ± 0.25	20.00 ± 0.30	2.00 ± 0.20	22.00 ± 0.40	7.00 ± 0.25

■ EFFECTIVE PARAMETERS

CORES	EFFECTIVE PARAMETERS				
	C ₁ (mm ⁻¹)	Le(mm)	Ae(mm ²)	Ve(mm ³)	Wt(g/set)
ET25/9.2	0.82	37.09	44.97	1667.87	9.00

Type : T Cores (EMI Suppression)

Ordering Code:

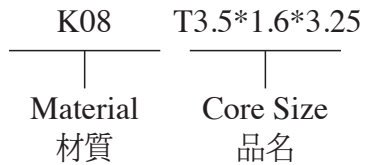

Shape:

Type:1

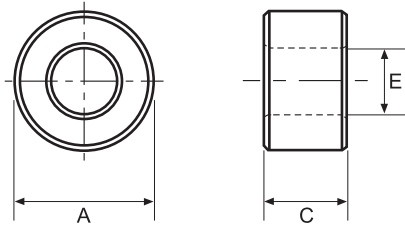

Type:2

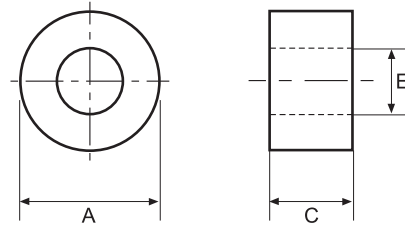

■ DIMENSIONS AND EFFECTIVE PARAMETERS

CORES	DIMENSIONS (mm)			Impedance		Type
	A	E	C	25MHz (min)	100MHz (min)	
T3.5x1.6x3.25	3.50 ± 0.20	1.60 ± 0.15	3.25 ± 0.20	17	35	2
T4x2x3	4.00 ± 0.20	2.00 ± 0.10	3.00 ± 0.20	14	30	1
T5.84x3.05x1.52	5.84 ± 0.25	3.05 ± 0.15	1.52 ± 0.10	8	23	1
T6.35x3.18x6	6.35 ± 0.25	3.18 ± 0.20	6.00 ± 0.30	28	62	1
T7.6x3.6x4.2	7.60 ± 0.30	3.60 ± 0.20	4.20 ± 0.20	20	38	1
T8x4x3	8.00 ± 0.30	4.00 ± 0.15	3.00 ± 0.15	20	59	2
T9.52x4.8x3.18	9.52 ± 0.25	4.80 ± 0.20	3.18 ± 0.25	16	35	1
T10.5x5.5x5	10.50 ± 0.35	5.50 ± 0.20	5.00 ± 0.30	20	38	1
T12x6x4	12.00 ± 0.40	6.00 ± 0.20	4.00 ± 0.30	18	36	1
T12.7x7.92x6.35	12.70 ± 0.40	7.92 ± 0.25	6.35 ± 0.30	20	40	1
T13x7x7	13.00 ± 0.40	7.00 ^{+0.40} / _{-0.00}	7.00 ± 0.30	25	50	1
T14.27x6.35x5.08	14.27 ± 0.40	6.35 ± 0.25	5.08 ± 0.20	24	50	1
T16x9x4	16.00 ± 0.50	9.00 ± 0.30	4.00 ± 0.20	13	30	1
T17.42x9.52x12.7	17.42 ± 0.50	9.52 ± 0.30	12.70 ± 0.40	44	88	1
T18.5x10x5	18.50 ± 0.50	10.00 ± 0.30	5.00 ± 0.30	42	70	1
T20x10x5	20.00 ± 0.50	10.00 ± 0.30	5.00 ± 0.20	23	56	1
T25x15x12	25.00 ± 0.50	15.00 ± 0.30	12.00 ± 0.40	35	80	1
T31x19x22	31.00 ± 0.70	19.00 ± 0.50	22.00 ± 0.60	63	117	1
T38.1x19.05x12.7	38.10 ± 0.70	19.05 ± 0.50	12.70 ± 0.40	48	87	1

Type : T Cores

Ordering Code:

Shape:

K08	T2.03*1.27*0.76	HP	G□
Material 材質	Core Size 品名	Coating 塗裝	Gapped AL Value

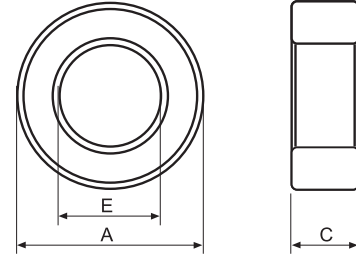

C : Epoxy Coating of Halogen-Free UC : Epoxy Coating of UL & Halogen
 HP : Parylene Coating of Halogen-Free P : Parylene Coating of Halogen

■ DIMENSIONS AND EFFECTIVE PARAMETERS

CORES	DIMENSIONS (mm)			EFFECTIVE PARAMETERS				
	PARYLENE COATING DIMENSIONS (mm)			C _i (mm ⁻¹)	L _e (mm)	A _e (mm ²)	V _e (mm ³)	Wt(g/set)
A	E	C						
T2.03x1x0.76	2.03 ± 0.15	1.00 ± 0.15	0.76 ± 0.15	12.16	4.76	0.39	1.86	0.009
	2.03 ± 0.15	1.00 ± 0.15	0.76 ± 0.15					
T2.03x1.1x0.64	2.03 ± 0.15	1.10 ± 0.15	0.64 ± 0.15	16.52	4.92	0.30	1.46	0.007
	2.03 ± 0.15	1.10 ± 0.15	0.64 ± 0.15					
T2.03x1.27x0.64	2.03 ± 0.15	1.27 ± 0.15	0.64 ± 0.15	21.31	5.18	0.24	1.26	0.006
	2.03 ± 0.15	1.27 ± 0.15	0.64 ± 0.15					
T2.03x1.27x0.76	2.03 ± 0.15	1.27 ± 0.15	0.76 ± 0.15	17.95	5.18	0.29	1.00	0.007
	2.03 ± 0.15	1.27 ± 0.15	0.76 ± 0.15					
T2.5x1.5x1.3	2.50 ± 0.15	1.50 ± 0.15	1.30 ± 0.15	9.67	6.28	0.65	4.08	0.020
	2.50 ± 0.15	1.50 ± 0.15	1.30 ± 0.15					
T2.54x1.27x0.76	2.54 ± 0.15	1.27 ± 0.15	0.76 ± 0.15	12.40	5.98	0.48	2.89	0.014
	2.54 ± 0.15	1.27 ± 0.15	0.76 ± 0.15					
T2.54x1.27x1	2.54 ± 0.15	1.27 ± 0.15	1.00 ± 0.15	9.42	5.98	0.64	3.80	0.018
	2.54 ± 0.15	1.27 ± 0.15	1.00 ± 0.15					
T2.54x1.27x1.27	2.54 ± 0.15	1.27 ± 0.15	1.27 ± 0.15	7.42	5.98	0.81	4.83	0.022
	2.54 ± 0.15	1.27 ± 0.15	1.27 ± 0.15					
T2.54x1.27x2.06	2.54 ± 0.15	1.27 ± 0.15	2.06 ± 0.15	4.58	5.98	1.31	7.83	0.037
	2.54 ± 0.15	1.27 ± 0.15	2.06 ± 0.15					
T3.05x1.27x1.3	3.05 ± 0.15	1.27 ± 0.15	1.30 ± 0.15	5.87	6.79	1.16	7.85	0.038
	3.05 ± 0.15	1.27 ± 0.15	1.30 ± 0.15					
T3.05x1.27x2	3.05 ± 0.15	1.27 ± 0.15	2.00 ± 0.15	3.81	6.79	1.78	12.08	0.055
	3.05 ± 0.15	1.27 ± 0.15	2.00 ± 0.15					
T3.05x1.5x2	3.05 ± 0.15	1.50 ± 0.15	2.00 ± 0.15	4.61	7.15	1.55	11.08	0.053
	3.05 ± 0.15	1.50 ± 0.15	2.00 ± 0.15					
T3.05x1.5x2.06	3.05 ± 0.15	1.50 ± 0.15	2.06 ± 0.15	4.48	7.15	1.60	11.41	0.053
	3.05 ± 0.15	1.50 ± 0.15	2.06 ± 0.15					
T3.05x1.68x2.06	3.05 ± 0.15	1.68 ± 0.15	2.06 ± 0.15	5.27	7.43	1.41	10.48	0.048
	3.05 ± 0.15	1.68 ± 0.15	2.06 ± 0.15					
T3.05x1.78x1.78	3.05 ± 0.15	1.78 ± 0.15	1.78 ± 0.15	6.71	7.59	1.13	8.58	0.041
	3.05 ± 0.15	1.78 ± 0.15	1.78 ± 0.15					
T3.05x1.78x2	3.05 ± 0.15	1.78 ± 0.15	2.00 ± 0.15	5.97	7.59	1.27	9.64	0.046
	3.05 ± 0.15	1.78 ± 0.15	2.00 ± 0.15					



■ ELECTRICAL CHARACTERISTICS

CORES	AL ± 25% (nH/N ²)										
	K07	K08	K081	K10	K11	K12	K17	B30	B45	B60	B90
T2.03x1x0.76	72										
T2.03x1.1x0.64	53	60									
T2.03x1.27x0.64	41	47									
T2.03x1.27x0.76			55								
T2.5x1.5x1.3		105									
T2.54x1.27x0.76	70	80	80			120					
T2.54x1.27x1			106							80	
T2.54x1.27x1.27	120	144	144				290				
T2.54x1.27x2.06				274							
T3.05x1.27x1.3			170								
T3.05x1.27x2		263	263				560				
T3.05x1.5x2		218		272							
T3.05x1.5x2.06							475				
T3.05x1.68x2.06							405				
T3.05x1.78x1.78		149									
T3.05x1.78x2							355				

Remark:

1. AL Value Testing Condition : 100kHz, 100mV, 1Ts. If testing condition is different from ACME's, please specify upon request & ordering.
2. Coating Material : Toroid Size T8 and Below:clear parylene coating, breakdown voltage:1000Vdc, coating thickness : 0.05mm max.

Type : T Cores

Ordering Code:

Shape:

K08	T3.3*1.2*1.6	HP	G□
Material 材質	Core Size 品名	Coating 塗裝	Gapped AL Value

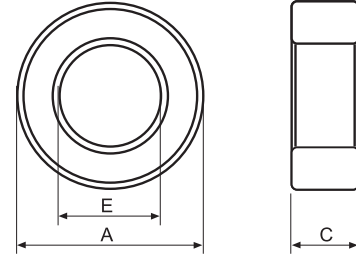

C : Epoxy Coating of Halogen-Free UC : Epoxy Coating of UL & Halogen
 HP : Parylene Coating of Halogen-Free P : Parylene Coating of Halogen

■ DIMENSIONS AND EFFECTIVE PARAMETERS

CORES	DIMENSIONS (mm)			EFFECTIVE PARAMETERS				
	PARYLENE COATING DIMENSIONS (mm)			C _i (mm ⁻¹)	Le(mm)	Ae(mm ²)	Ve(mm ³)	Wt(g/set)
	A	E	C					
T3.3x1.2x1.6	3.30 ± 0.15	1.20 ± 0.15	1.60 ± 0.15	4.20	7.06	1.68	11.86	0.060
	3.30 ± 0.15	1.20 ± 0.15	1.60 ± 0.15					
T3.3x1.3x1.3	3.30 ± 0.15	1.30 ± 0.15	1.30 ± 0.15	5.55	7.22	1.30	9.39	0.050
	3.30 ± 0.15	1.30 ± 0.15	1.30 ± 0.15					
T3.43x1.27x3	3.43 ± 0.15	1.27 ± 0.15	3.00 ± 0.15	2.28	7.38	3.24	23.92	0.114
	3.43 ± 0.15	1.27 ± 0.15	3.00 ± 0.15					
T3.5x1.5x3	3.50 ± 0.15	1.50 ± 0.15	3.00 ± 0.15	2.62	7.85	3.00	23.56	0.115
	3.50 ± 0.15	1.50 ± 0.15	3.00 ± 0.15					
T3.5x1.8x1.3	3.45 ± 0.15	1.75 ± 0.15	1.30 ± 0.15	7.53	8.33	1.11	9.20	0.044
	3.45 ± 0.15	1.75 ± 0.15	1.30 ± 0.15					
T3.5x1.8x3.2	3.50 ± 0.15	1.80 ± 0.15	3.20 ± 0.15	3.06	8.33	2.72	22.64	0.109
	3.50 ± 0.15	1.80 ± 0.15	3.20 ± 0.15					
T3.94x2.24x1.27	3.94 ± 0.15	2.24 ± 0.15	1.27 ± 0.15	9.20	9.75	1.06	10.34	0.050
	3.94 ± 0.15	2.24 ± 0.15	1.27 ± 0.15					
T4x2x1	4.00 ± 0.30	2.00 ± 0.30	1.00 ± 0.20	9.42	9.42	1.00	9.42	0.050
	4.00 ± 0.30	2.00 ± 0.30	1.00 ± 0.20					
T4x2x2	4.00 ± 0.20	2.00 ± 0.20	2.00 ± 0.20	4.71	9.42	2.00	18.85	0.099
	4.00 ± 0.20	2.00 ± 0.20	2.00 ± 0.20					
T4x2x3	4.00 ± 0.20	2.00 ± 0.20	3.00 ± 0.20	3.14	9.42	3.00	28.27	0.137
	4.00 ± 0.20	2.00 ± 0.20	3.00 ± 0.20					
T4.83x2.29x1.27	4.83 ± 0.12	2.29 ± 0.15	1.27 ± 0.15	6.93	11.18	1.61	18.04	0.087
	4.83 ± 0.12	2.29 ± 0.15	1.27 ± 0.15					
T4.95x2.97x2.79	4.95 ± 0.10	2.97 ± 0.10	2.79 ± 0.10	4.50	12.44	2.76	34.36	0.18
	4.95 ± 0.10	2.97 ± 0.10	2.79 ± 0.10					
T5.38x2.97x2.79	5.38 ± 0.10	2.97 ± 0.10	2.79 ± 0.10	3.90	13.12	3.36	44.10	0.22
	5.38 ± 0.10	2.97 ± 0.10	2.79 ± 0.10					
T5.84x3.05x1.52	5.84 ± 0.15	3.05 ± 0.15	1.52 ± 0.15	6.58	1.96	2.12	30.00	0.146
	5.84 ± 0.15	3.05 ± 0.15	1.52 ± 0.15					
T5.84x3.05x1.8	5.84 ± 0.15	3.05 ± 0.15	1.80 ± 0.15	5.56	13.96	2.51	35.06	0.169
	5.84 ± 0.15	3.05 ± 0.15	1.80 ± 0.15					
T6x3x2	6.00 ± 0.30	3.00 ± 0.30	2.00 ± 0.20	4.71	14.14	3.00	42.41	0.210
	6.00 ± 0.30	3.00 ± 0.30	2.00 ± 0.20					
T7.62x3.18x3.18	7.62 ± 0.15	3.18 ± 0.15	3.18 ± 0.15	2.40	16.96	7.06	119.76	0.580
	7.62 ± 0.15	3.18 ± 0.15	3.18 ± 0.15					



■ ELECTRICAL CHARACTERISTICS

CORES	AL ± 25% (nH/N²)													
	L2	K07	K08	K081	K10	K11	K12	K15	K17	B30	B45	B50	B60	B90
T3.3x1.2x1.6	18													
T3.3x1.3x1.3	14													
T3.43x1.27x3					550									
T3.5x1.5x3				385										
T3.5x1.8x1.3			135											
T3.5x1.8x3.2									700					
T3.94x2.24x1.27			110											
T4x2x1			105											
T4x2x2			210	210										
T4x2x3		280								120	180			
T4.83x2.29x1.27									308					
T4.95x2.97x2.79			220	220	280		330			80	125		165	250
T5.38x2.97x2.79			255	255	320		385			95	145		190	290
T5.84x3.05x1.52			76		95									
T5.84x3.05x1.8														203
T6x3x2			210	210							120			
T7.62x3.18x3.18				420										470

Remark:

1. AL Value Testing Condition : 100kHz, 100mV, 1Ts. If testing condition is different from ACME's, please specify upon request & ordering.
2. Coating Material : Toroid Size T8 and Below:clear parylene coating, breakdown voltage:1000Vdc, coating thickness : 0.05mm max.

Type : RH Cores

Ordering Code:



Shape:

Type:1

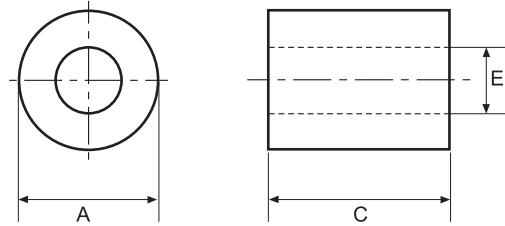

Type:2

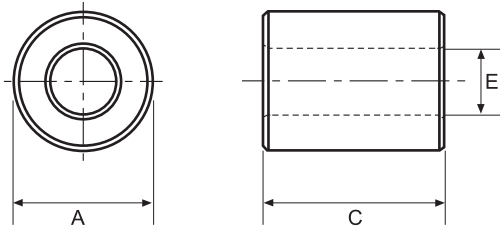

Type:3

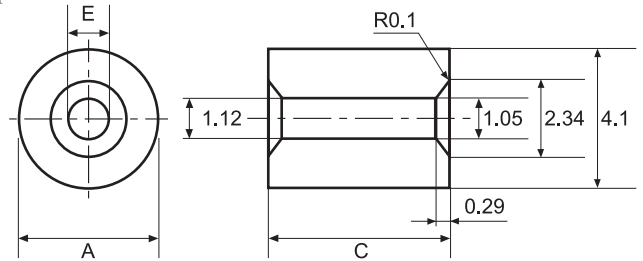

■ DIMENSIONS AND EFFECTIVE PARAMETERS

CORES	DIMENSIONS (mm)			Impedance		Type
	A	E	C	25MHz (min)	100MHz (min)	
RH2.03x0.89x2.67	2.03 ± 0.10	2.67 ± 0.25	0.89 ± 0.07	–	–	2
RH3x1.2x3.5	3.00 ± 0.15	1.20 ± 0.15	3.50 ± 0.20	–	–	1
RH3.5x0.9x4.5	3.50 ± 0.20	0.90 ± 0.15	4.50 ± 0.20	–	–	3
RH3.5x1.2x4	3.50 ± 0.20	1.20 ± 0.15	4.00 ± 0.20	26	47	1
RH3.5x1.6x5	3.50 ± 0.20	1.60 ± 0.10	5.00 ± 0.20	23	44	1
RH4x2x6	4.00 ± 0.20	2.00 ± 0.15	6.00 ± 0.30	24	41	2
RH5x1.5x6.35	5.00 ± 0.20	1.50 ± 0.15	6.35 ± 0.25	43	71	2
RH5.8x3.8x10	5.80 ± 0.30	3.80 ± 0.20	10.00 ± 0.30	26	59	2
RH6.35x3.18x15.9	6.35 ± 0.15	3.18 ± 0.20	15.90 ± 0.50	64	115	2
RH7.8x4x12.7	7.80 ± 0.25	4.00 ± 0.20	12.70 ± 0.40	45	100	2
RH9x4.5x10	9.00 ± 0.25	4.50 ± 0.15	10.00 ± 0.70	36	65	2
RH9.52x5.08x19.05	9.52 ± 0.30	5.08 ± 0.20	19.05 ± 0.70	65	117	2
RH10.5x5.5x20	10.50 ± 0.35	5.50 ± 0.20	20.00 ± 0.50	75	140	2
RH12x5.6x30	12.00 ± 0.40	5.60 ± 0.20	30.00 ± 0.70	130	213	2
RH12.7x7.92x12.7	12.70 ± 0.40	7.92 ± 0.25	12.70 ± 0.40	35	75	2
RH14.27x6.35x28.57	14.27 ± 0.40	6.35 ± 0.20	28.57 ± 0.70	120	200	2
RH15.88x7.87x28.57	15.88 ± 0.50	7.87 ± 0.25	28.57 ± 0.70	110	192	2
RH16x9x28	16.00 ± 0.50	9.00 ± 0.30	28.00 ± 0.70	100	160	2
RH17.42x9.52x28.57	17.42 ± 0.50	9.52 ± 0.30	28.57 ± 0.70	94	155	2
RH18.5x10x28.57	18.50 ± 0.50	10.00 ± 0.30	28.57 ± 0.70	100	175	2
RH26x13x28.57	26.00 ± 0.50	13.00 ± 0.30	28.57 ± 0.80	113	193	2



ACME Electronics (Guangzhou) Co., Ltd., Guangdong province, China



ACME Electronics (Kunshan) Co., Ltd., Jiang-Su Province, China

Our Commitment

- Emphasis on Customer Service
- Emphasis on Manufacturing Quality
- Emphasis on Competitive Pricing
- Emphasis on Timely Deliveries
- Mutual Beneficial Customer Partnerships
- Maintain TS 16949, ISO 9001, QC 080000 and ISO 14001



ACME Ferrite Product SDN. BHD., Ipoh, Malaysia

Our Quality Policy

Our corporate philosophy is rooted firmly in achieving and maintaining MANUFACTURING EXCELLENCE through the efficient production of the highest quality products for our customers.

This will be accomplished by an EMPOWERED, QUALITY CONSCIOUS WORK FORCE and SUPPLIER BASE through CONTINUOUS IMPROVEMENT.



ACME Electronics Corporation
越峯電子材料股份有限公司

總公司：

台北市114內湖區基湖路39號8樓
Tel : +886-2-26503337
Fax : +886-2-26599511

觀音廠：

桃園縣328觀音工業區國建二路2號
Tel : +886-3-4837238
Fax : +886-3-4837239

越峰電子（廣州）有限公司：

中國廣東省廣州增城市增江街東區府前東路2號
Tel : +86-20-32851888 郵政編號：511300
Fax : +86-20-32851666

越峰電子（廣州）廈門辦事處：

中國福建省廈門市集美區杏林鎮錦園村錦中路6-1號
Tel : +86-592-6380606 郵政編號：361022
Fax : +86-592-6380505

越峰電子（廣州）成都辦事處：

中國四川省成都市金牛區蜀躍東路138號翡翠海灣6-2-2室
Tel : +86-28-61892015 郵政編號：610036
Fax : +86-28-61892341

越峰電子（昆山）有限公司：

中國江蘇省昆山市黃浦江北路533號
Tel : +86-512-57932888 郵政編號：215337
Fax : +86-512-57664667

越峰電子（昆山）威海辦事處：

中國山東省威海市經濟開發區青島中路98號
藍星萬象城22B座210室
Tel : +86-631-5989263 郵政編號：264205
Fax : +86-631-5989193

ACME Ferrite Products Sdn. Bhd.

Plot 15, Jalan Industri 6
Kawasan Perindustrian Jelapang II(ZPB)
Jelapang, 30020, Ipoh,
Perak, Malaysia
Tel : +605-5269149, 5269151, 5269152
Fax : +605-5269296

Head Office:

8th Floor., No.39, Ji-Hu Rd., Nei-Hu Dist., Taipei, 114, Taiwan
Tel : +886-2-26503337
Fax : +886-2-26599511

Kuan-Yin Factory:

No.2, Kuo-Chien 2nd Rd., Kuan-Yin Industrial District,
Taoyuan County, 328, Taiwan
Tel : +886-3-4837238
Fax : +886-3-4837239

ACME Electronics (Guangzhou) Co., Ltd:

No.2 Fuqian East Road, Zengjiang Street East Square,
Guangzhou-Zengcheng City, 511300, Guangdong Province, China
Tel : +86-20-32851888
Fax : +86-20-32851666

ACME Electronics (Guangzhou) Xia Men Branch:

No. 6-1, Jin Middle Rd, Jin Yuan Village, Xing Lin, Xia Men
City, 361022, Fu Jian Province, China
Tel : +86-592-6380606
Fax : +86-592-6380505

ACME Electronics(Guangzhou)Chengdu Branch:

Rm 6-2-2, No.138 Shuyue East Rd, Jinniu Distract.
Chengdu City, 610036, Sichuan Province, China
Tel : +86-28-61892015
Fax : +86-28-61892341

ACME Electronics (Kunshan) Co., Ltd:

No.533 Huangpujiang North Rd., Kunshan City,
215337, Jiang-Su Province, China
Tel : +86-512-57932888
Fax : +86-512-57664667

ACME Electronics (Kunshan) Weihai Branch:

Rm 210, Building 22B, LANXING VIIIENTIANE Garden,
No. 98 Qiandao Middle Rd. Economic Development Zone,
Weihai City, 264205, Shandong Province, China
Tel : +86-631-5989263
Fax : +86-631-5989193

ACME Ferrite Products Sdn. Bhd.

Plot 15, Jalan Industri 6
Kawasan Perindustrian Jelapang II(ZPB)
Jelapang, 30020, Ipoh,
Perak, Malaysia
Tel : +605-5269149, 5269151, 5269152
Fax : +605-5269296